

RADIO & TELEVISION NEWS

JANUARY
1954

35 CENTS
In-Canada 40¢

INCLUDING

*TV & RADIO
ENGINEERING*

IN THIS ISSUE

THE THEREMIN

TROUBLESHOOTING
THE TURRET TUNER

80-METER
NOVICE TRANSMITTER

THE KARLSON
SPEAKER ENCLOSURE

KNOW YOUR 1954
MOTOROLA TV RECEIVERS

A "BASKET CHASSIS"
TRANSMITTER

TRANSISTOR METRONOME

MY START IN TV
SERVICING

THE CONVAIR
ANALOGUE COMPUTER

(See Page 61)

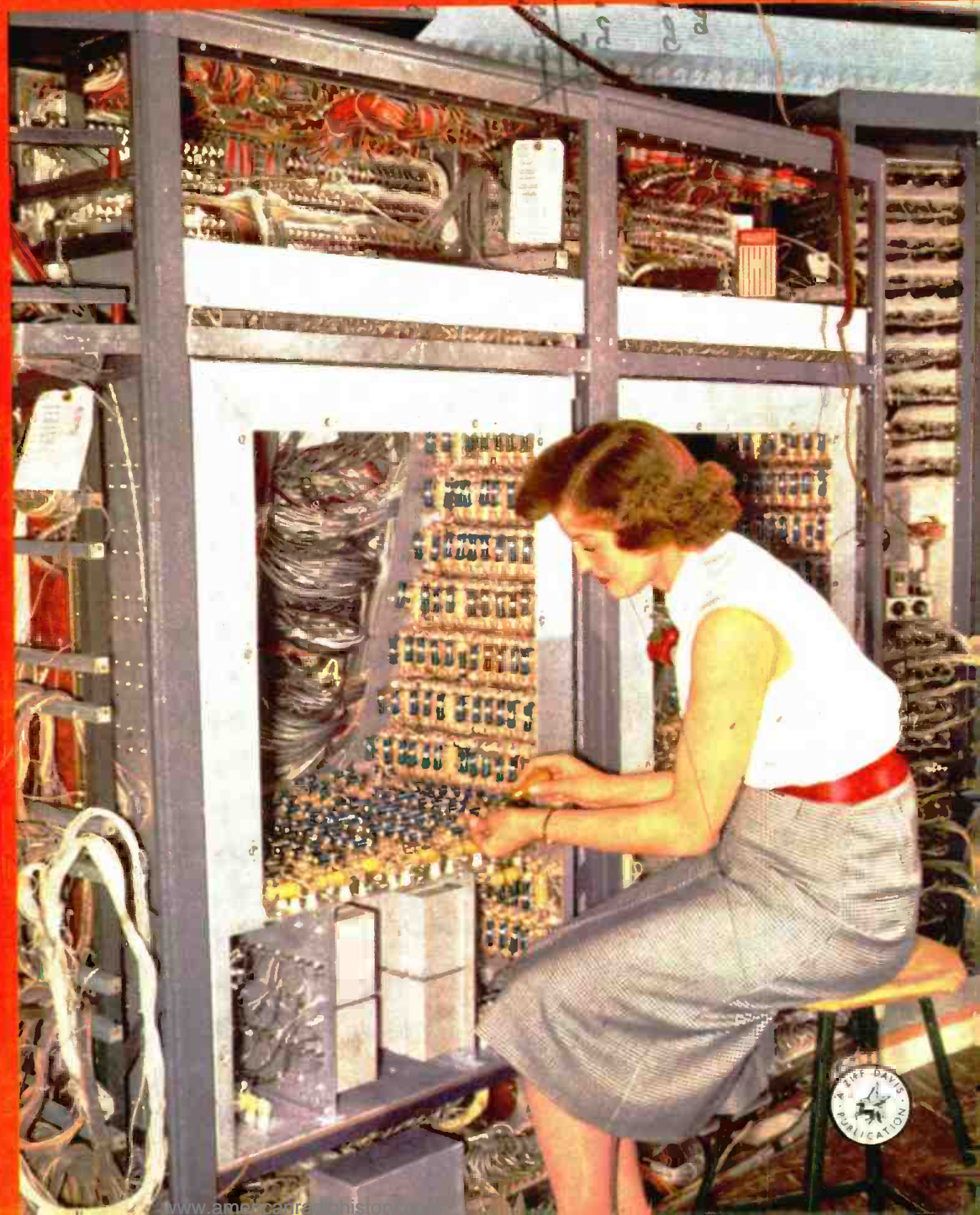

This is to certify that

Frank's Radio

BOND

and the

1. GUARANTEE FOR NINE MONTHS
2. Use only Raytheon tubes
3. Not charge for service
4. Test tubes before use

EXTRA

The Daily News

EXTRA

RAYTHEON BONDED PROGRAM ENTERS TENTH YEAR

SERVICE DEALERS' MOST EFFECTIVE SALES AID



...the most effective sales aid...
 ...service dealers' most effective sales aid...
 ...Raytheon Bonded Program...
 ...enters tenth year...
 ...service dealers' most effective sales aid...



...the most effective sales aid...
 ...service dealers' most effective sales aid...
 ...Raytheon Bonded Program...
 ...enters tenth year...
 ...service dealers' most effective sales aid...

RAYTHEON COMPANY
 Roy Tucker, President
 No. _____ A

It was way back in 1945 that Raytheon, the first tube manufacturer to recognize the Service Dealers' need for help in combating public mistrust, provided that help through the *Raytheon Bonded Electronic Technician Program*.

For the past nine years this Raytheon support has helped many thousands of Service Dealers gain customer confidence and good will — substantially in-

crease their volume and profit.

Today, with the addition of television, the Raytheon Bond is more important than ever. And today, as always, if you can qualify for it, your status as a Raytheon Bonded Electronic Technician *costs you not one cent*. It is *Raytheon's investment in your future*.

If you're interested in making more money, ask your Raytheon Tube Distributor to tell you about the Raytheon Bonded Program. He'll be pleased to tell you how this powerful sales stimulator can help you.



RAYTHEON MANUFACTURING COMPANY

Receiving Tube Division
 Newton, Mass., Chicago, Ill., Atlanta, Ga., Los Angeles, Cal.

Excellence in Electronics

RAYTHEON MAKES ALL THESE: RECEIVING AND PICTURE TUBES • RELIABLE SUBMINIATURE AND MINIATURE TUBES • GERMANIUM DIODES AND TRANSISTORS • NUCLEONIC TUBES • MICROWAVE TUBES



“I’m glad I waited...”

Here’s how I solved a problem that bothered me . . . and may be bothering you.

Many of my favorite recordings happen to be 78’s. They mean as much to me as any of my newer LP’s or 45’s. Changing pickups was often a real nuisance—and yet I wasn’t willing to give up the superior quality of my two Pickering cartridges.

Last fall my dealer offered a suggestion. “Wait a little longer,” he said. “You’ll be glad you did.”

He was right. I now have Pickering’s new turn-over cartridge. A simple flip of the handy lever and I’m ready to play any favorite that fits my mood—whether it’s standard or microgroove. *More than that, I’d swear my recordings sound better than ever.*

I’m glad I waited . . . but you won’t have to.

Ask your dealer to show you this convenient new turn-over cartridge. Have him demonstrate it. See if you, too, don’t hear the difference!

PICKERING and company incorporated • Oceanside, L. I., New York

PICKERING PROFESSIONAL AUDIO COMPONENTS

“For those who can hear the difference”

...Demonstrated and sold by Leading Radio Parts Distributors everywhere.
For the one nearest you and for detailed literature, write Dept. C-3



RADIO & TELEVISION NEWS is published monthly by the Ziff-Davis Publishing Company at 64 E. Lake St., Chicago 1, Ill. Entered as second-class matter, July 21, 1948, at the Post Office, Chicago, Ill., under the act of March 3, 1879. Authorized by Post Office Department, Ottawa, Canada, as second-class matter. SUBSCRIPTION RATES: Radio & Television News—one year, U. S. and Possessions, and Canada \$4.00; Pan American countries and all other foreign countries \$5.00. Radio-Electronic Engineering Edition—one year, U. S. and Possessions, and Canada \$6.00; Pan American countries and all other foreign countries \$7.00. Postmaster—Please return undelivered copies under form 3589 to 64 E. Lake St., Chicago 1, Ill.

Editor and Asst. Publisher
OLIVER READ, D.Sc., W1E7T

Managing Editor
WM. A. STOCKLIN, B.S.

Technical Editor
H. S. RENNE, M.S.

Service Editor
CHARLES TEPFER

Assistant Editors
P. B. HOEFER
M. C. MAGNA

Television Consultant
WALTER H. BUCHSBAUM

Short-Wave Editor
KENNETH R. BOORD

Art Editor
FRANK SAYLES

Draftsmen
A. A. GANS, W2TSP
J. A. GOLANEK

Advertising Manager
L. L. OSTEN

Midwest Adv. Manager
JOHN A. RONAN, JR.

Western Adv. Manager
JOHN E. PAYNE



COVER PHOTO: Technician works on the analogue computer console at Convair's Computer Facility in San Diego. This million dollar unit solves aircraft flight problems. For full operational details, see story on page 61. (Ektachrome by Roger W. Jett)

ZIFF-DAVIS PUBLISHING COMPANY

Chairman of the Board and Publisher
WILLIAM B. ZIFF

President
B. G. DAVIS

Vice-Presidents
H. J. MORGANROTH

M. H. FROELICH

Secretary-Treasurer
G. E. CARNEY

BRANCH OFFICES

CHICAGO (11)
 64 E. Lake St., AN 3-5200
 LOS ANGELES (14)
 Staffer Center, 900 Wilshire Blvd., Mich. 9856



Reg. U. S. Pat. Off.
 Radio News Trademark Reg. U. S. Pat. Office • Television News Trademark Reg. U. S. Pat. Office.

*First in radio-
 television-audio-electronics*

Average Paid Circulation over 230,000

CONTENTS

JANUARY, 1954

The Theremin.....	Robert Moog, K2AMH	37
Pages from a Tape Editor's Notebook (Part 3).....	Donald C. Hoefler	40
A "Basket Chassis" Transmitter.....	Joseph F. Sodaro, W6ZRT	42
The "Compleat Fidelity" (Part 3).....	Don V. R. Drenner	44
Know Your 1954 Motorola TV Receivers.....		45
A Transistor Metronome.....	Louis E. Garner, Jr.	50
80-Meter Novice Transmitter.....	David D. Bulkley, W2QUJ & Merritt F. Kirchhoff, W2FAR	52
Troubleshooting the Turret Tuner.....	Milton H. Lowe	54
TV Stations on the Air.....		57
The Karlson Speaker Enclosure.....	John E. Karlson	58
The Convair Analogue Computer.....	R. D. Horwitz	61
A Dual Channel Recording System (Part 3).....	Oliver Read	62
Certified Record Revue.....	Bert Whyte	64
Phone-Plug Amplifier.....	H. F. Starke & C. W. Martel	65
My Start in TV Servicing.....	Jay Stanley	66
The Electronorgan (Part 3).....	Richard H. Dorf	68
Mac's Radio Service Shop.....	John T. Frye	76
Measuring Resistance Between Tube Elements.....	Lloyd J. Austin	96
Service Hints on Motorola TV Sets.....		103
Headphones for Radio and TV.....	H. S. Renne	116
Radio-TV Service Industry News.....		124
New TV Grants Since Freeze Lift.....		148

DEPARTMENTS

For the Record.....	The Editor	8	Short-Wave.....	K. R. Boord	73
Spot Radio News.....		16	Technical Books.....		99
Within the Industry.....		26	What's New in Radio.....		132
New Audio Equipment.....		152			



COPYRIGHT 1953
 (All Rights Reserved)
ZIFF-DAVIS PUBLISHING COMPANY
 Editorial and Executive Offices
 366 Madison Ave., New York 17, N. Y.
VOLUME 51 • NUMBER 1



Member
 Audit Bureau of
 Circulations

SUBSCRIPTION SERVICE: All communications concerning subscriptions should be addressed to Circulation Dept., 64 E. Lake St., Chicago 1, Ill. Subscribers should allow at least four weeks for change of address.
CONTRIBUTIONS: Contributors are advised to retain a copy of their manuscripts and illustrations. Contributions should be mailed to the New York Editorial Office and must be accompanied by return postage. Contributions will be handled with reasonable care, but this magazine assumes no responsibility for their safety. Any copy accepted is subject to whatever adaptations and revisions are necessary to meet the requirements of this publication. Payment covers all author's, contributor's, and contestant's rights, title, and interest in and to the material accepted and will be made at our current rates upon acceptance. All photos and drawings will be considered as part of the material purchased.

**NOW... GET EVERYTHING YOU
NEED TO LEARN AND MASTER**

TELEVISION

**RADIO-ELECTRONICS
...AT HOME!**

**Use REAL commercial-type equip-
ment to get practical experience**

Your future deserves and needs every advantage you can give it! That's why you owe it to yourself to find out about one of the most COMPLETE, practical and effective ways now available to prepare AT HOME for America's billion dollar opportunity field of TELEVISION-RADIO-ELECTRONICS. See how you may get and keep the same type of basic training equipment used in one of the nation's finest training laboratories... how you may get real STARTING HELP toward a good job or your own business in Television-Radio-Electronics. Mail the coupon today for complete facts—including 89 ways to earn money in this thrilling newer field.

D. T. I., ALONE, INCLUDES BOTH MOVIES and HOME LABORATORY
In addition to easy-to-read lessons, you get the use of HOME MOVIES—an outstanding training advantage—plus 16 big shipments of Electronic parts. Perform over 300 fascinating experiments for practical experience. Build and

**Get information packed
publication FREE!**

keep real commercial-type test
equipment shown at right.

**89 WAYS
TO
EARN
MONEY
IN TELEVISION
RADIO-ELECTRONICS**

MODERN LABORATORIES

If you prefer, get all your preparation in our new Chicago Training Laboratories—one of the finest of its kind. Ample instructors, modern equipment. Write for details!

MILITARY SERVICE

If you're subject to military service, the information we have for you should prove very helpful. Mail coupon today.

ACT NOW! MAIL COUPON TODAY!

DEFOREST'S TRAINING, INC.
2533 N. Ashland Avenue, Chicago 14, Ill.

RN-1-K

I would like your valuable information-packed publication showing how I can get started toward a good job or my own business in Television-Radio-Electronics.

Name..... Age.....
Street..... Apt.....
City..... Zone..... State.....



Build and Keep this BIG DTI Engi-
neered TV set — easily converted to
U. H. F. (DTI offers another Home
Training, but without the TV set.)

Here's the REAL THING!

**SET UP YOUR OWN
HOME LABORATORY**



Multimeter



Oscilloscope

HOME
MOVIES

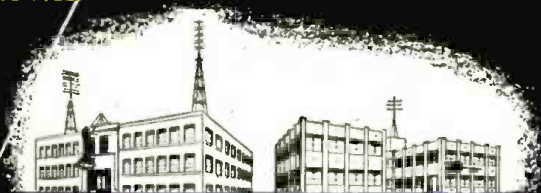

DEFOREST'S TRAINING, INC.
AFFILIATED WITH
DEVRY Technical INSTITUTE
CHICAGO 14, ILLINOIS

-the MOST popular!

C • D • R
R O T O R S

built to last

dependable

powerful

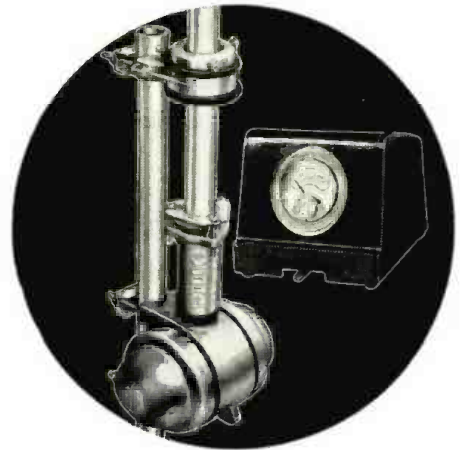

TR-12 ... a special combination value consisting of complete rotor including thrust bearing... handsome modern design cabinet with meter control dial \$47.95

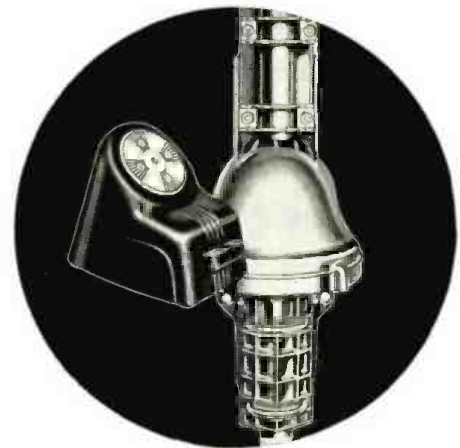

TR-2 ... the **HEAVY DUTY** rotor especially suited for special TV antenna installations. Complete rotor with "compass control" cabinet having illuminated "perfect pattern" dial \$49.95

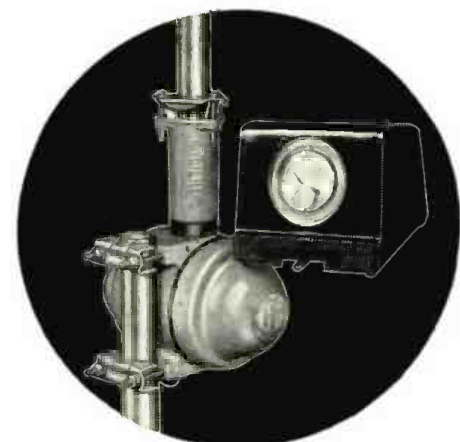

TR-11 ... the same as the TR-12 without the thrust bearing, complete with meter control dial cabinet \$44.95

ONE OF THE WORLD'S LARGEST ELECTRONICS MANUFACTURERS SINCE 1912



CORNELL-DUBILIER
SOUTH PLAINFIELD, N. J.



THE RADIART CORP.
CLEVELAND 13, OHIO

HERE ARE
31 REASONS
WHY THE

Hallicrafters SX-88

is the hottest ham news in years!



SX-88

SELECTIVITY—
For the first time, selectivity
from 10 kc to 250 cycles in six steps.
Compare with ANY other receiver!

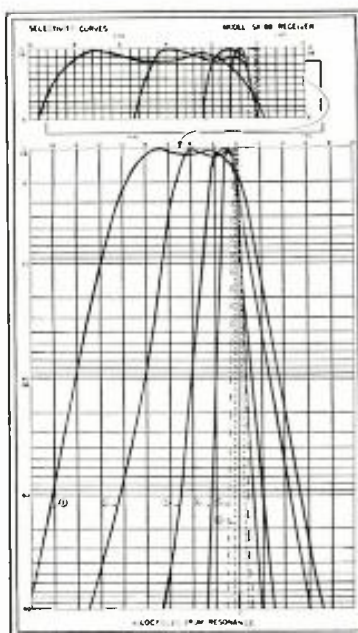
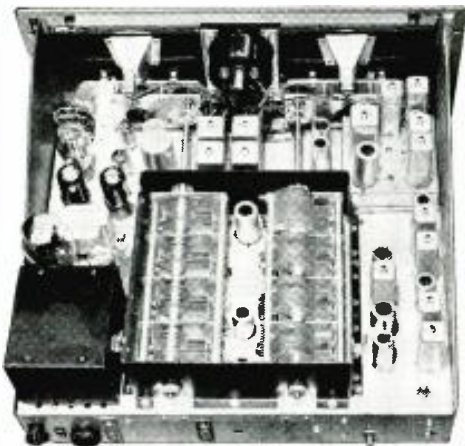

1. Heavy gauge steel welded chassis for mechanical stability.
2. Full precision gear drive for main and band spread tuning.
3. Six position Band Width Control (selectivity) from 250 cycles to 10 kc.
4. 10 watt inverse feed back and push-pull audio output.
5. Exalted B.F.O. for tops in single side band reception.
6. Buffer amplifier in B.F.O. circuit.
7. Antenna trimmer.
8. Amplified and delayed A.V.C.
9. Built-in 100 kc calibration crystal.
10. Second conversion oscillators crystal controlled.
11. Inertia tuning (fly wheels both dials).
12. Full frequency coverage from 535 kc. to 33 mc.
13. Calibrated electrical band spread 160, 80, 40, 20, 15, 11, and 10 meters.
14. Logging scales on each tuning shaft.
15. Dial locks on each tuning shaft.
16. Tuning dial indicators resetable from front panel for maximum calibration accuracy.
17. Auxiliary A.C. socket on rear of chassis.
18. Illuminated band-in-use indicator.
19. Illuminated S meter.
20. Dual S meter calibration S units and microvolts.
21. Auxiliary power socket plus .6 amps at 6.3 volts and 10 ma at 150 volts for accessories.
22. Standard 8 $\frac{3}{4}$ " by 19" panel for rack mounting if desired.
23. 50 kc i.f. output jack via cathode follower for teletype converter, etc.
24. Five position response control (tone control).
25. Two r.f. stages (Bands II to VI).
26. 17 tubes plus voltage regulator, ballast tube and rectifier.
27. Automatic noise limiter circuit.
28. Phono Jack.
29. Audio output transformer for 3.2, 8, 500/600 ohm loads.
30. Fuse for overload protection.
31. Auxiliary sensitivity control permits monitoring of local transmissions in standby position.

Hallicrafters

World's Leading Exclusive Manufacturer of Communications and High Fidelity Equipment, Radio and Television

4401 West Fifth Avenue, Chicago 24, Illinois • Hallicrafters Ltd., 51 Camden Street, Toronto, Canada

January, 1954

NEW SMALL VERSATILE
P.A. Lavalier
 DYNAMIC MICROPHONE
 For Chest, Desk or Hand Use



MODEL 647

**FIRST EVER IN
 SUCH SMALL SIZE
 FOR PUBLIC ADDRESS**

Unlike any lapel microphone, the "647" offers full-range E-V dynamic microphone quality, ruggedness and performance characteristics for indoor and outdoor use. Response 60-13,000 cps, specially compensated for chest resonance. Output -57 db.

Only 4" x 1", the "647" can be worn around the neck, or used in the hand, on a desk or on a boom. When suspended from the neck, a unique clip provides secure support—frees the user's hands for gestures and demonstrations, permits him to move around.



Exclusive E-V Acoustalloy diaphragm is virtually indestructible. Acoustically-treated grille minimizes effects of wind and breath blasts. Supplied complete with combination neck cord and tie clip for microphone, belt clip for cable, and 18 ft. cable. (The Model 416 Rubber Desk Stand is additional at \$5.00 list.) Available in Low or Hi-Z.

Model 647. List Price, \$80.00
 Net, \$48.00

See your E-V Distributor
 or Send for Bulletin 201

Electro-Voice

410 CARROL ST. • BUCHANAN, MICHIGAN
 Export: 13 E. 40th St., New York 16, U. S. A. Cables: Arlab

For the **RECORD.**

BY THE EDITOR

"THE PAPERS SAY . . ."

THE beginning of each year is always accompanied by many forecasts of "things to come" in the electronic industry. Reporters and columnists of the daily press apparently delight in interviewing top industry leaders for statements of achievements made in television, radio, industrial electronics, and a host of other related activities. Much of the resulting copy appearing in the dailies serves to properly inform the public as to what has been accomplished by industry and what it expects to achieve in the immediate future.

A few of these columnists have, evidently, at least a speaking knowledge of the electronic industry and are capable of interpreting statements correctly. Too many columnists, however, are prone to accept and print statements of fancy—rather than fact.

We read a recent column in a leading New York daily in which a columnist reported an interview with the top executive of a leading producer of television, radio, and industrial electronic equipment. Included was the statement, "A transistor is a speck of germanium imbedded in glass, the whole thing about three-quarters the size of a dime. It can do anything a vacuum tube can do, needs practically no power, will probably replace all the tubes in a radio set and eventually in a television set. Some day it may even replace the picture tube."

Now, as technicians, let's let OUR imagination for things fantastic replace our common sense and knowledge of vacuum tubes and become instead that of the man or woman riding to work *via* the subway and reading the above column. Our thinking might go something like this.

Over the year, our subway rider recalls, this columnist has been one of his favorites and his writings have been gospel. He usually accepts and believes what is said. If the reporter says that "a transistor can do anything a vacuum tube can do" and "needs practically no power" then whyinell doesn't Junior replace the tubes in his 1 kw. ham rig with transistors and run 'em from an old dry cell. After all, it would save him twenty bucks a month to the power company.

And what about a transistor replacing the picture tube without any explanation as to how this would be done? Our reader certainly would have to stretch his imagination to the breaking point to visualize an image less than the diameter of a dime!

Technicians believe, for example,

that multiple circuits (using transistors) may eventually replace the conventional picture tube—but the image will be projected on a screen and not a direct facsimile on the face of the transistor (unless it be super king-size).

Reporting on the status of color television, high-fidelity, and other facets of our industry has been most misleading to the public. If this situation continues it will become most difficult to hold public confidence in electronic development.

It takes no genius to foresee the tremendous future applications for electronics in industry, in the home, in commerce, and in communications. For example the history of the development of monochrome TV proves without a doubt that the public acceptance of small pictures was very short-lived. With all the ballyhoo in the press about color television receivers and 14½" screens (actually about 12") at prices 1000 dollars and higher it seems logical to assume that these, too, will be very short-lived.

If history repeats itself, and we think it will, then good quality color television sets with 17" or 21" screens will be on the market in the year 1955 at a price below a "kilobuck."

And, we'll bet our bottom dollar that the image will not be seen on a tri-color transistor.

If reporters and columnists of the daily press would take the time to check and properly interpret the maze of claims and predictions made by publicity-minded executives they would do much to add prestige and authority to their columns. But, of even greater benefit to their public would be the real service that can be given by crystalizing the state of the arts as they exist and to accept statements with "a grain of salt" for further verification before pounding the typewriter to write about things highly technical.

Our quarrel is directed solely to those responsible for copy that misleads the public on things technical. The average prospective customer for a television set and the high-fidelity listener are but two examples of the frustration that exists in the minds of many prospective purchasers. The morning gazette says, "Why wait for color TV? It's here!" or "You can have true super high-fidelity in your home for \$29.50" while the evening bugle would probably say, "Color TV probable in late 1954" or "Hi-Fi is yours for less than \$500.00."

And so it goes! O.R.

the only **COMPLETE** catalog
for Everything in TV, Radio
and Industrial Electronics

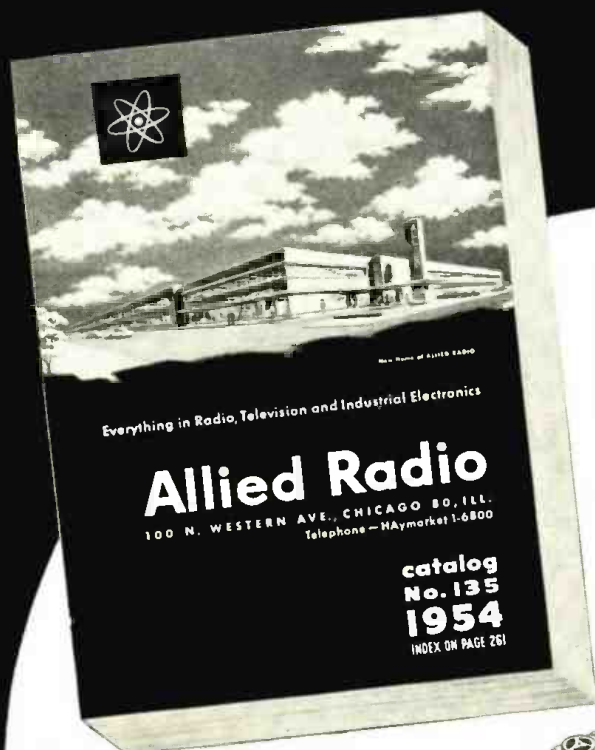

FREE value-packed

1954 ALLIED 268-PAGE CATALOG

The World's Largest Stocks

- TV and Radio Parts
- Test Instruments
- High-Fidelity Equipment
- Custom TV Chassis
- AM, FM Tuners and Radios
- Recorders and Supplies
- P.A. Systems, Accessories
- Amateur Station Gear
- Builders' Kits, Supplies
- Equipment for Industry

Fastest Service in Electronic Supply

SEND FOR THE LEADING
ELECTRONIC
BUYING GUIDE
FREE!



SEND FOR IT TODAY

Get ALLIED'S latest catalog—268 pages packed with the world's largest selection of quality equipment at lowest, money-saving prices. See all the latest releases in custom TV chassis, TV antennas and accessories; AM and FM tuners and radios; everything in High-Fidelity custom components; latest P. A. Systems and accessories; recorders and supplies; Amateur receivers, transmitters and station gear; specialized industrial electronic equipment; test instruments; builders' kits; huge listings of parts, tubes, tools, books—your choice of the world's most complete stocks of quality equipment. ALLIED gives you every buying advantage: speedy shipment, expert personal help, lowest prices, assured satisfaction. Get the big 1954 ALLIED Catalog. Keep it handy—and save time and money. Send for your FREE copy today.

**SAVE ON EVERYTHING
IN ELECTRONICS**

NEW HOME OF
ALLIED RADIO
ultra-modern facilities
TO SERVE YOU BEST



EASY PAY TERMS

Use ALLIED'S liberal Easy Payment Plan—only 10% down, 12 months to pay—no carrying charge if you pay in 60 days. Available on Hi-Fi and P.A. units, recorders, TV chassis, test instruments, Amateur gear.

TV and HI-FI SPECIALISTS

To keep up with developments in High-Fidelity and TV, look to ALLIED. Count on us for all the latest releases and largest stocks of equipment in these important fields. If it's anything in High-Fidelity or Television—we have it in stock!

ALLIED RADIO
World's Largest Electronic Supply House

ALLIED RADIO CORP., Dept. 1-A-4
100 N. Western Ave., Chicago 80, Illinois

Send FREE 268-Page 1954 ALLIED Catalog

Name _____

Address _____

City _____ Zone _____ State _____

NORTH, EAST, SOUTH, WEST...

Federal has a lead-in

Whatever the area or atmosphere... city or fringe... rain, snow ice, heat, dust, salt spray, polluted air or radiation... you'll find the answer in these quality-controlled cables by Federal —

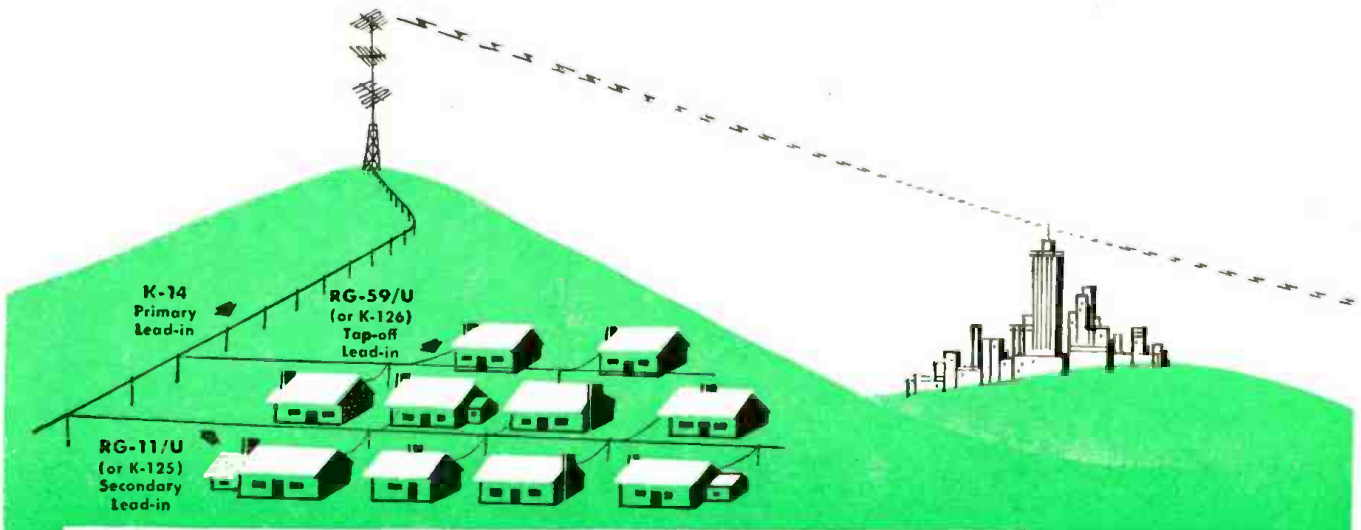

FOR COMMUNITY TV IT'S *Federal's* "BIG 5"



K-14—71-ohm shielded primary transmission line for community distribution systems. Famous for lowest line loss, long cable runs and fewer amplifiers required. Capacitance: 21.5 mmf/ft. Attenuation DB 100/ft: .57–50 Mc; .90–100 Mc; 1.42–200 Mc; 2.3–400 Mc.



RG-11/U—75-ohm shielded low-loss coaxial. One of the best small-diameter cables. Tops as a community TV secondary lead-in. Seven strands #26 tinned copper. Capacitance: 20.5 mmf/ft. Attenuation DB 100/ft: 1.5–50 Mc; 2.15–100 Mc; 3.2–200 Mc; 4.7–400 Mc.



RG-59/U—73-ohm coaxial TV lead-in cable. Highly efficient as a community system pole-to-house tap-off. Meets all needs wherever a high-grade installation is a must. Capacitance: 21 mmf/ft. Attenuation DB 100/ft: 2.7–50 Mc; 4.0–100 Mc; 5.7–200 Mc; 8.5–400 Mc.

Use these 2 for Community TV radiation:

FOR URBAN CENTERS



K-111—300-ohm shielded, balanced TV lead-in developed by FTR. Minimizes noise, snow, ghosts due to transmission line pick-ups. Ideal for many areas where good TV was impossible before. Capacitance: 4.2 mmf/ft. Attenuation DB 100/ft: 3.4–100 Mc; 6.6–400 Mc.



TV-1184—300-ohm dumbbell-shaped TV lead-in. A standard low-cost lead-in for areas without unusual conditions. Cinnamon-brown color is highly resistant to ultraviolet. Two conductors: 7/#28. Capacitance: 4 mmf/ft. Attenuation DB 100/ft: 1.28–100 Mc; 3.0–400 Mc.



TV-1182—300-ohm deluxe type heavy-duty TV lead-in with 90 mil. web. Insulated with "silver" polyethylene, Federal development that provides maximum weather protection and long life. Capacitance: 4 mmf/ft. Attenuation DB 100/ft: 1.22–100 Mc; 2.85–400 Mc.

Non-Radiating Lead-ins for MULTIPLEX TV SYSTEMS



K-125—75-ohm coaxial TV lead-in cable. Double-shielded and jacketed. Formerly listed as SP-75.



K-126—73-ohm coaxial TV lead-in cable. Double-shielded and jacketed. Formerly listed as SP-76.

K-125 alternates for RG-11/U as secondary lead-in
K-126 alternates for RG-59/U as tap-off lead-in

Wherever there are **TV** customers...

for the finest **VHF-UHF**

Federal's **TV-1185** *

...**"PIPELINE"** of the Air!

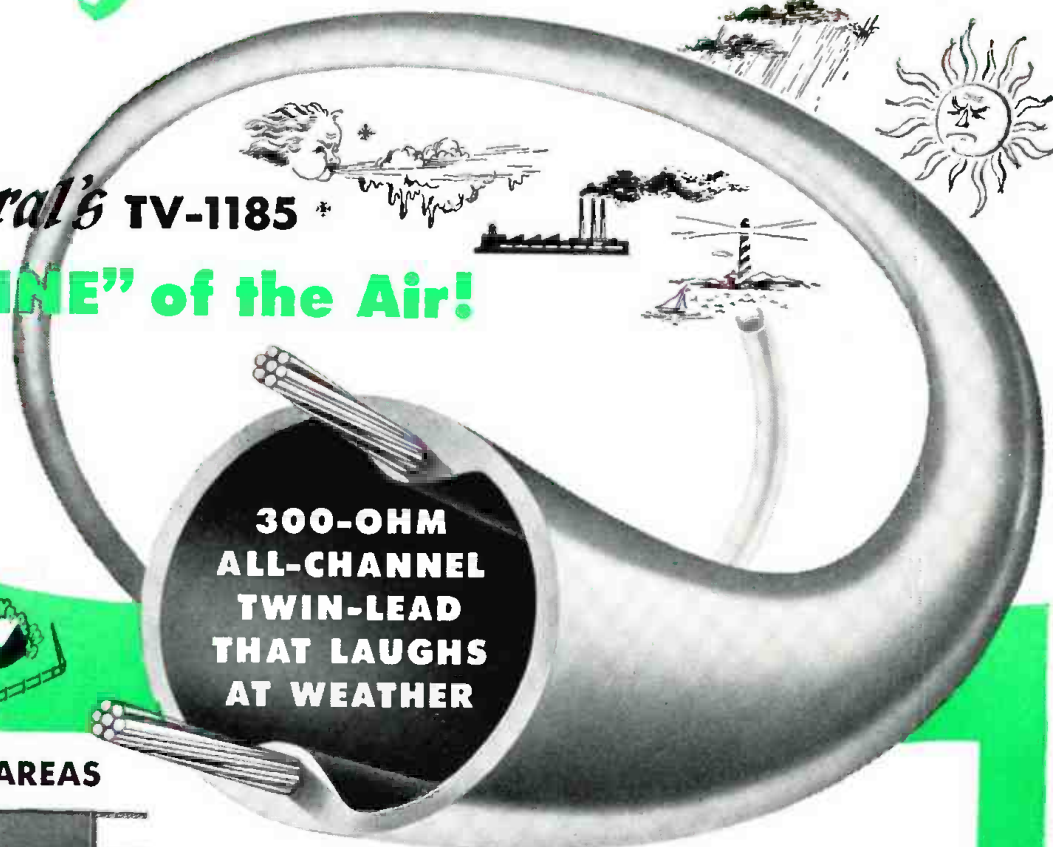

**300-OHM
ALL-CHANNEL
TWIN-LEAD
THAT LAUGHS
AT WEATHER**

FOR FRINGE AREAS



TV-1182—Provides remarkably low line loss in fringe areas. Outstanding for resistance to weather and sunlight. Silver-colored insulation blends with any color scheme in home decoration.



K-200 (RG-86/U)—200-ohm heavy-duty ultra low-loss lead-in. Particularly adaptable to remote-area installations — especially long runs and multi-stack antennas. Also used with rombics.

**See your local
Federal Distributor
or write to
Federal direct
Dept. D-959**

**TV-1185's "Silver" pigmentation lets you
INSTALL IT and FORGET IT!**

FEDERAL's TV-1185 is virtually a "pipeline" for better-than-ever TV reception... VHF or UHF. Insulated with the revolutionary Federal-developed "silver" polyethylene, TV-1185 is amazingly tough, flexible and efficient.

TV-1185 leads in Weatherometer tests... fights heat, resists moisture and other destructive deposits... minimizes deterioration due to sunlight.

TV-1185 keeps the energy field inside the weather-proof sheath... providing exceptionally low loss... more constant impedance... a better TV picture regardless of area or length of lead. It's easy to install and tight-seal against all atmospheric conditions.

There's no finer tubular lead-in of its type on the market today!

Capacitance: 4 mmf/ft. Attenuation DB 100/ft:
0.5-10 Mc; 0.95-50 Mc; 1.25-100 Mc; 1.7-200 Mc;
2.6-400 Mc; 3.0-500 Mc; 4.5-1000 Mc.

Product of America's leading producer of solid dielectric coaxial cables



Federal Telephone and Radio Company

SELENIUM-INTELIN DEPARTMENT

100 KINGSLAND ROAD, CLIFTON, N. J.

In Canada: Federal Electric Manufacturing Company, Ltd., Montreal, P. Q.

Export Distributors: International Standard Electric Corp., 67 Broad St., N. Y.

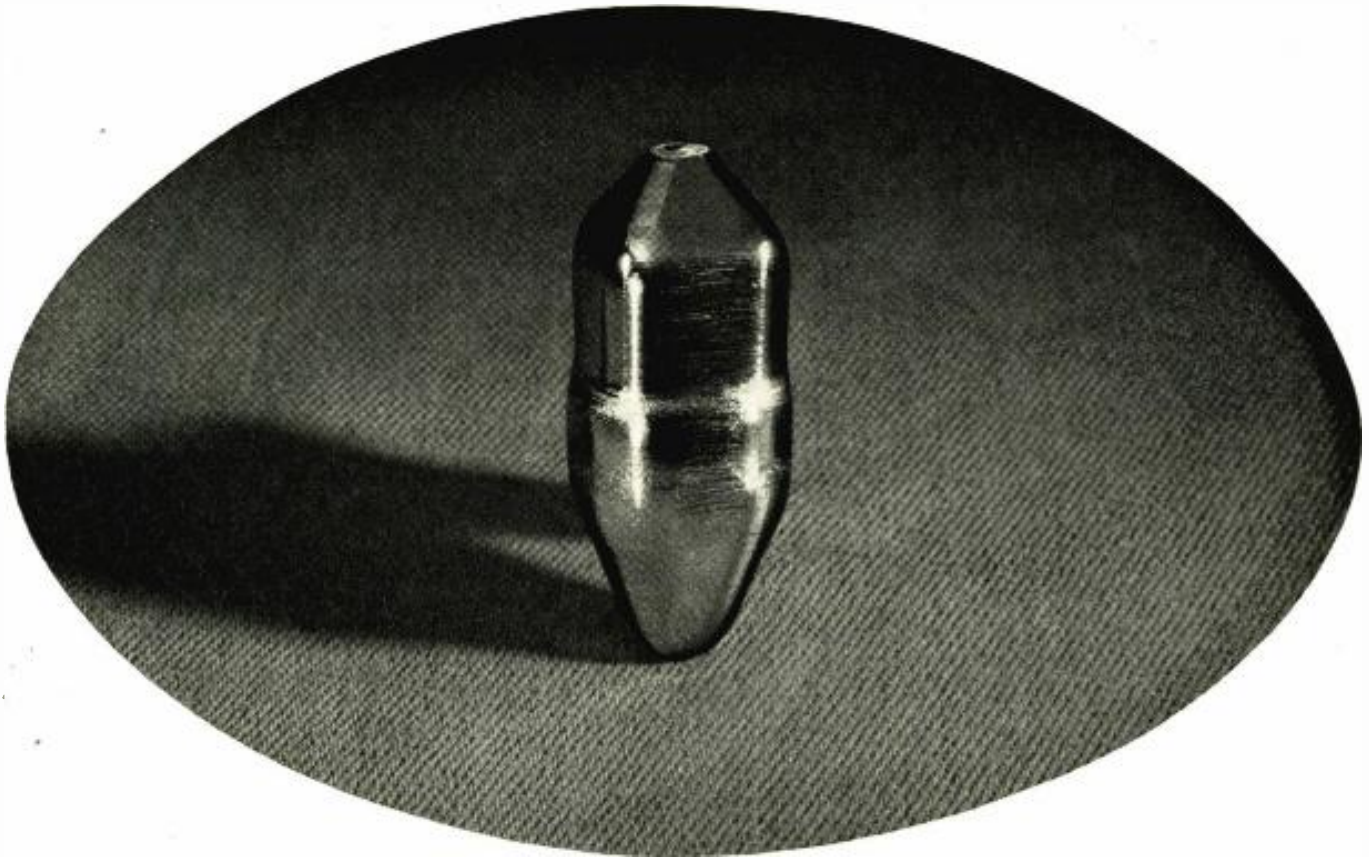

Germanium crystal grown at Bell Telephone Laboratories (life size). It is sliced into hundreds of minute pieces to make *Transistors*. Transistor action depends on the flow of positive current-carriers as well as electrons, which are negative. Arsenic—a few parts per 100,000,000—added to germanium produces prescribed excess of electrons. With gallium added, positive carriers predominate. Latest junction type *Transistor* uses both kinds of germanium in the form of a sandwich.

THEY GREW IT FOR TRANSISTORS

Heart of a *Transistor*—Bell Telephone Laboratories' new pea-size amplifier—is a tiny piece of germanium. If *Transistors* are to do their many jobs well, this germanium must be of virtually perfect crystalline structure and uniform chemical composition. But it doesn't come that way in nature.

So—Bell scientists devised a new way to *grow* the kind of crystals they need, from a melt made of the natural product. By adding tiny amounts of special alloying substances to the melt, they produce germanium that is precisely tailored for specific uses in the telephone system.

This original technique is another example of the way Bell Laboratories makes basic discoveries—in this case the *Transistor* itself—and then follows up with practical ways to make them work for better telephone service.

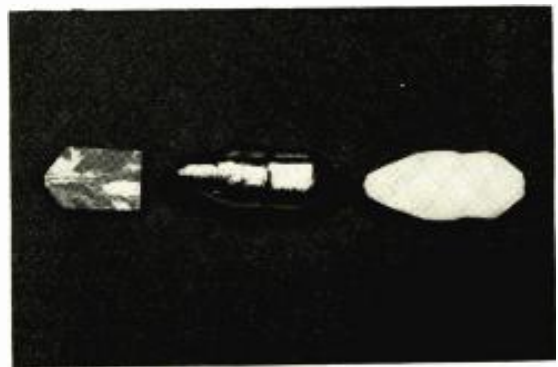

Section of natural germanium, left, shows varying crystal structure. At right is sectioned single crystal grown at Bell Laboratories.

IMPROVING TELEPHONE SERVICE FOR AMERICA PROVIDES CAREERS FOR
CREATIVE MEN IN SCIENTIFIC AND TECHNICAL FIELDS

BELL TELEPHONE LABORATORIES



RADIO & TELEVISION NEWS

Get in on the TV boom . . . starting today!

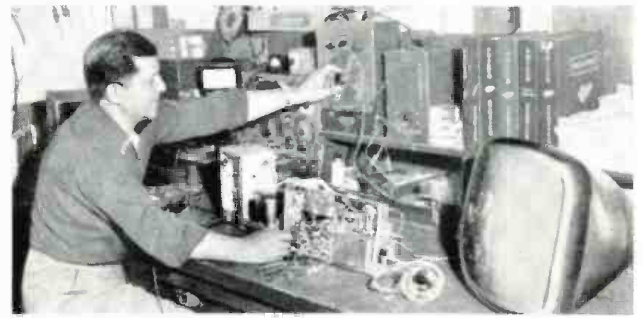

- Prepare now for the new Radio-TV-Electronics boom. Get in on VHF and UHF . . . aviation and mobile radio . . . color TV . . . binaural sound! The International Correspondence Schools can help you!

If you've ever thought about Radio or Television as a career . . . if you have the interest, but not the training . . . if you're waiting for a good time to start . . . NOW'S THE TIME!

No matter what your previous background, I.C.S. can help you. If Radio-TV servicing is your hobby, I.C.S. can make it your own profitable business. If you're interested in the new developments in Electronics, I.C.S. can give you the basic courses of training you need. If you have the job but want faster progress, I.C.S. can qualify you for promotions and pay raises.

I.C.S. training is *success-proved* training. Hundreds of I.C.S. graduates hold top jobs with top firms like R.C.A., G.E., DUMONT, I.T.&T. Hundreds of others have high ratings in military and civil service. Still others have successful businesses of their own.

With I.C.S., you get the rock-bottom basics and theory as well as the all-important bench practice and experimentation. You learn in your spare time—no interference with business or social life. You set your own pace—progress as rapidly as you wish.

Free career guidance: Send today for the two free success books, the 36-page "How to Succeed" and the informative catalog on the course you check below. No obligation. Just mark and mail the coupon. With so much at stake, you owe it to yourself to act—and act fast!

I. C. S. Scranton 9, Penna.

CHECK THESE SEVEN FAMOUS I. C. S. COURSES —ONE FOR YOU!

- PRACTICAL RADIO-TELEVISION ENGINEERING**—Foundation course for radio-television career. Basic principles plus advanced training. Radio, Sound, TV.
- TELEVISION TECHNICIAN**—To qualify you for high-level technical positions in television. Camera, studio, transmitter techniques, Manufacture, sale and installation of TV equipment.
- TELEVISION RECEIVER SERVICING**—Installation, servicing, conversion, Dealership. For the man who knows about radio and wants TV training.
- RADIO & TELEVISION SERVICING**—Designed to start you repairing, installing and servicing radio and television receivers soon after starting the course.
- RADIO & TELEVISION SERVICING WITH TRAINING EQUIPMENT**—Same as above but with addition of high-grade radio servicing equipment and tools.
- RADIO OPERATING COURSE**—Special course to help you pass the Government examination for operator's licenses. Code. TV. FM. Radioregulations.
- INDUSTRIAL ELECTRONICS**—Broad, solid background course devoted to the electron tube and to its many applications.

INTERNATIONAL CORRESPONDENCE SCHOOLS

ICS

BOX 2250-D, SCRANTON 9, PENNA.

Without cost or obligation, send me "HOW to SUCCEED" and the booklet about the course BEFORE which I have marked X:

- | | | | | |
|--|---|--|---|---|
| <ul style="list-style-type: none"> <input type="checkbox"/> ART <input type="checkbox"/> Commercial Art <input type="checkbox"/> Magazine Illustrating <input type="checkbox"/> Fashion Illustrating <input type="checkbox"/> Cartooning <input type="checkbox"/> Sketching and Painting <input type="checkbox"/> Show Card and Sign Lettering <input type="checkbox"/> AUTOMOTIVE <input type="checkbox"/> Automobile Mechanic <input type="checkbox"/> Auto Elec. Technician <input type="checkbox"/> Auto Body Rebuilding and Refinishing <input type="checkbox"/> Diesel—Gas Engines <input type="checkbox"/> AVIATION <input type="checkbox"/> Aeronautical Engineering Jr. <input type="checkbox"/> Aircraft Engine Mechanic <input type="checkbox"/> Airplane Drafting <input type="checkbox"/> BUILDING <input type="checkbox"/> Architecture <input type="checkbox"/> Arch. Drafting <input type="checkbox"/> Building Contractor <input type="checkbox"/> Estimating <input type="checkbox"/> Carpenter and Mill Work <input type="checkbox"/> Carpenter Foreman <input type="checkbox"/> Reading Blueprints <input type="checkbox"/> House Planning <input type="checkbox"/> Plumbing | <ul style="list-style-type: none"> <input type="checkbox"/> Heating <input type="checkbox"/> Painting Contractor <input type="checkbox"/> Air Conditioning <input type="checkbox"/> Electrician <input type="checkbox"/> BUSINESS <input type="checkbox"/> Business Administration <input type="checkbox"/> Certified Public Accountant <input type="checkbox"/> Bookkeeping and Accounting <input type="checkbox"/> Office Management <input type="checkbox"/> Stenography and Typing <input type="checkbox"/> Secretarial <input type="checkbox"/> Federal Tax <input type="checkbox"/> Business Correspondence <input type="checkbox"/> Letter-writing Improvement <input type="checkbox"/> Personnel and Labor Relations <input type="checkbox"/> Advertising <input type="checkbox"/> Retail Business Management <input type="checkbox"/> Managing Small Business <input type="checkbox"/> Ocean Navigation <input type="checkbox"/> Sales Management <input type="checkbox"/> Short Story Writing <input type="checkbox"/> Creative Salesmanship <input type="checkbox"/> Traffic Management <input type="checkbox"/> CHEMISTRY <input type="checkbox"/> Chemical Engineering <input type="checkbox"/> Chemistry <input type="checkbox"/> Analytical Chemistry | <ul style="list-style-type: none"> <input type="checkbox"/> Petroleum—Nat'l Gas <input type="checkbox"/> Pulp and Paper Making <input type="checkbox"/> Plastics <input type="checkbox"/> CIVIL STRUCTURAL ENGINEERING <input type="checkbox"/> Civil Engineering <input type="checkbox"/> Structural Engineering <input type="checkbox"/> Surveying and Mapping <input type="checkbox"/> Structural Drafting <input type="checkbox"/> Highway Engineering <input type="checkbox"/> Reading Blueprints <input type="checkbox"/> Construction Engineering <input type="checkbox"/> Sanitary Engineering <input type="checkbox"/> DRAFTING <input type="checkbox"/> Aircraft Drafting <input type="checkbox"/> Architectural Drafting <input type="checkbox"/> Electrical Drafting <input type="checkbox"/> Mechanical Drafting <input type="checkbox"/> Structural Drafting <input type="checkbox"/> Sheet Metal Drafting <input type="checkbox"/> Ship Drafting <input type="checkbox"/> Mine Surveying and Drafting <input type="checkbox"/> ELECTRICAL <input type="checkbox"/> Electrical Engineering <input type="checkbox"/> Electrician <input type="checkbox"/> Electrical Maintenance | <ul style="list-style-type: none"> <input type="checkbox"/> Electrical Drafting <input type="checkbox"/> Electric Power and Light <input type="checkbox"/> Lineman <input type="checkbox"/> HIGH SCHOOL <input type="checkbox"/> High School Subjects <input type="checkbox"/> Mathematics <input type="checkbox"/> Commercial <input type="checkbox"/> Good English <input type="checkbox"/> MECHANICAL AND SHOP <input type="checkbox"/> Mechanical Engineering <input type="checkbox"/> Industrial Engineering <input type="checkbox"/> Industrial Supervision <input type="checkbox"/> Foremanship <input type="checkbox"/> Mechanical Drafting <input type="checkbox"/> Machine Design-Drafting <input type="checkbox"/> Machine Shop Practice <input type="checkbox"/> Tool Design <input type="checkbox"/> Industrial Instrumentation <input type="checkbox"/> Machine Shop Inspection <input type="checkbox"/> Reading Blueprints <input type="checkbox"/> Toolmaking <input type="checkbox"/> Gas—Electric Welding <input type="checkbox"/> Heat Treatment—Metallurgy <input type="checkbox"/> Sheet Metal Work <input type="checkbox"/> Sheet Metal Pattern Drafting <input type="checkbox"/> Refrigeration | <ul style="list-style-type: none"> <input type="checkbox"/> POWER <input type="checkbox"/> Combustion Engineering <input type="checkbox"/> Diesel—Electric <input type="checkbox"/> Electric Light and Power <input type="checkbox"/> Stationary Steam Engineering <input type="checkbox"/> Stationary Fireman <input type="checkbox"/> RADIO, TELEVISION COMMUNICATIONS <input type="checkbox"/> Practical Radio—TV Eng'ring <input type="checkbox"/> Radio Operating <input type="checkbox"/> Radio and TV Servicing <input type="checkbox"/> Television—Technician <input type="checkbox"/> Electronics <input type="checkbox"/> Telephone Work <input type="checkbox"/> RAILROAD <input type="checkbox"/> Locomotive Engineer <input type="checkbox"/> Diesel Locomotive <input type="checkbox"/> Air Brakes <input type="checkbox"/> Car Inspector <input type="checkbox"/> Railroad Administration <input type="checkbox"/> TEXTILE <input type="checkbox"/> Textile Engineering <input type="checkbox"/> Cotton, Rayon, Woolen Wfg. <input type="checkbox"/> Carding and Spinning <input type="checkbox"/> Warping and Weaving <input type="checkbox"/> Loom Fixing <input type="checkbox"/> Throwing <input type="checkbox"/> Finishing and Dyeing <input type="checkbox"/> Textile Designing |
|--|---|--|---|---|

Name _____ Age _____ Home Address _____

City _____ Zone _____ State _____ Working Hours _____ A.M. to P.M. _____

Occupation _____ Canadian residents send coupon to International Correspondence Schools Canadian, Ltd., Montreal, Canada. . . . Special tuition rates to members of the U. S. Armed Forces.

**You can't
do without...**

SYLVANIA'S SEE-WELL TOOL KIT

A NEW, TIME-SAVING TOOL-SENSATION!

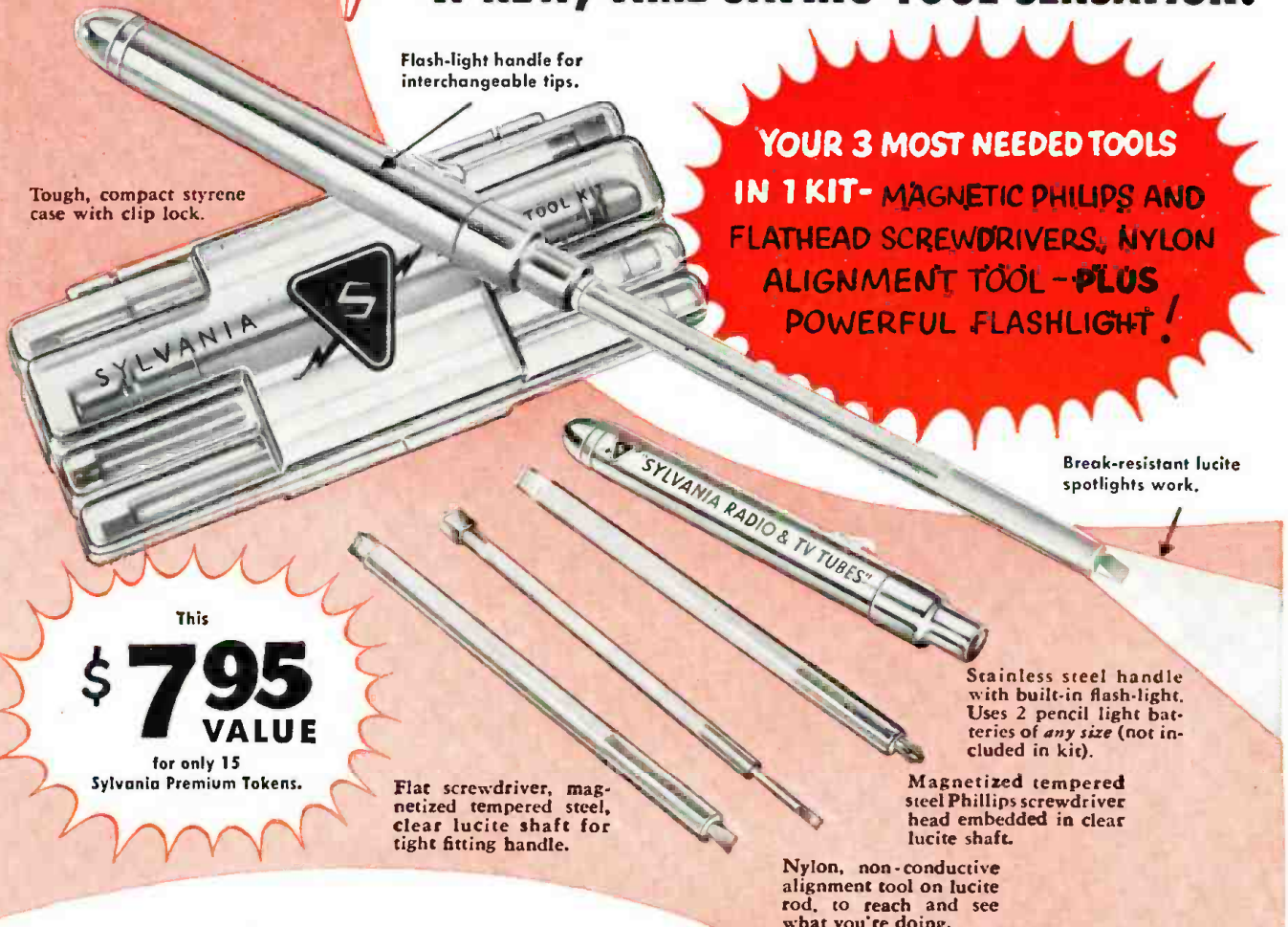

Tough, compact styrene case with clip lock.

Flash-light handle for interchangeable tips.

**YOUR 3 MOST NEEDED TOOLS
IN 1 KIT- MAGNETIC PHILIPS AND
FLATHEAD SCREWDRIVERS, NYLON
ALIGNMENT TOOL - PLUS
POWERFUL FLASHLIGHT!**

Break-resistant lucite spotlights work.

This
\$ 7.95
VALUE

for only 15
Sylvania Premium Tokens.

Stainless steel handle with built-in flash-light. Uses 2 pencil light batteries of any size (not included in kit).

Flat screwdriver, magnetized tempered steel, clear lucite shaft for tight fitting handle.

Magnetized tempered steel Phillips screwdriver head embedded in clear lucite shaft.

Nylon, non-conductive alignment tool on lucite rod, to reach and see what you're doing.

NO MORE FUMBLING inside dark radio and TV cabinets. At the flick of a switch, a bright light automatically focuses right at the spot you're seeking. Saves your time . . . improves your work.

3 Handy Tools in 1. Magnetized Phillips and Flathead screwdrivers, nylon alignment tool - all 3 built into break-resistant lucite shafts perfectly fitted to flashlight handle.

Without doubt, this SEE-WELL Tool Kit is one of the slickest, quickest service tools ever built!

See your Sylvania Distributor Today! He has this remarkable tool kit for you now - you need only 15 Sylvania Premium Tokens. The time to get this valuable Sylvania See-Well Tool Kit is NOW - so don't delay, order high quality Sylvania tubes TODAY.

Remember, you get 1 token with every 25 Sylvania Receiving Tubes or every Sylvania TV Picture Tube you buy.

SYLVANIA

Sylvania Electric Products Inc. Dept. 4R-3501, 1740 Broadway, New York 19, N. Y.

In Canada: Sylvania Electric (Canada) Ltd.
University Tower Bldg., St. Catherine Street, Montreal, P. Q.

LIGHTING • RADIO • ELECTRONICS • TELEVISION



RADIO & TELEVISION NEWS

ADVANCE! Raise your earning power—learn RADIO-TELEVISION-ELECTRONICS by SHOP-METHOD HOME TRAINING

GOOD JOBS AWAIT THE TRAINED RADIO-TV TECHNICIAN

There is a place for you in the great Radio-Television-Electronics industry when you are trained as National Schools will train you at home!

Trained technicians are in growing demand at good pay—in manufacturing, broadcasting, television, communications, radar, research laboratories, home Radio-TV service, and other branches of the field. National Schools Master Shop-Method Home Training, with newly added lessons and equipment, trains you in your spare time, right in your own home, for these fascinating opportunities. **OUR METHOD IS PROVED BY THE SUCCESS OF NATIONAL SCHOOLS TRAINED MEN, ALL OVER THE WORLD, SINCE 1905.**

EARN WHILE YOU LEARN

Many National students pay for all or part of their training with spare time earnings. We'll show you how you can do the same! Early in your training, you receive "Spare-time Work" Lessons which will enable you to earn extra money servicing neighbors' and friends' Radio and Television receivers, appliances, etc.

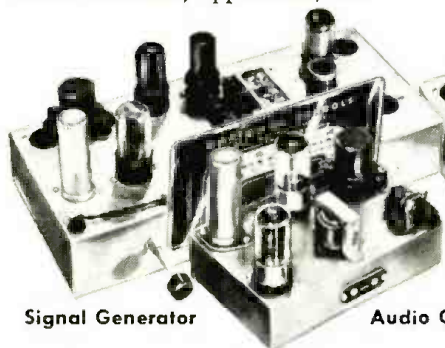

Signal Generator



T. R. F. Receiver

Audio Oscillator

National Schools Training is All-Embracing

National Schools prepares you for your choice of many job opportunities. Thousands of home, portable, and auto radios are being sold daily—more than ever before. Television is sweeping the country, too. Co-axial cables are now bringing Television to more cities, towns, and farms every day! National Schools' complete training program qualifies you in all fields. Read this partial list of opportunities for trained technicians:

Business of Your Own • Broadcasting
Radio Manufacturing, Sales, Service • Telecasting
Television Manufacturing, Sales, Service
Laboratories: Installation, Maintenance of Electronic Equipment
Electrolysis, Call Systems
Garages: Auto Radio Sales, Service
Sound Systems and Telephone Companies, Engineering Firms
Theatre Sound Systems, Police Radio
And scores of other good jobs in many related fields.

TELEVISION TRAINING

You get a complete series of up-to-the-minute lessons covering all phases of repairing, servicing and construction. The same lesson texts used by resident students in our modern and complete Television broadcast studios, laboratories and classrooms!

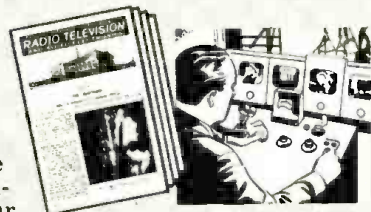

MASTER ALL PHASES!

Get Master Shop-Method Home Training from an Established Practical Resident School with its own Training Shops, Laboratories, Studios — almost 50 Years of Successful Experience in Training Ambitious Men.

We Bring National Schools To You!

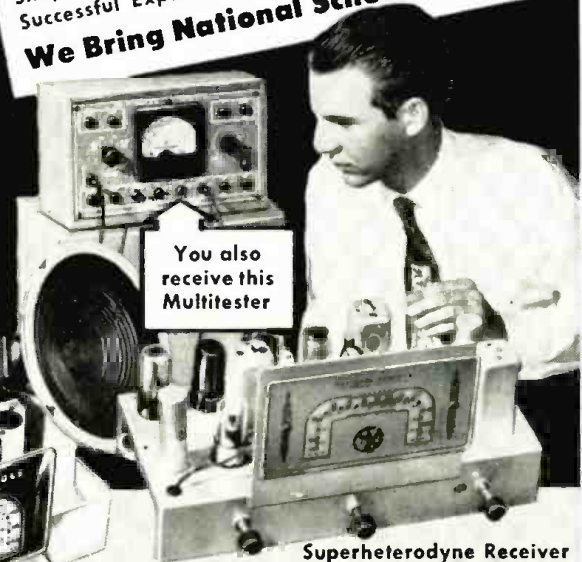

You also receive this Multitester

Superheterodyne Receiver

LEARN BY DOING

You receive and keep all the modern equipment shown above, including tubes and valuable, professional quality Multitester. No extra charges.

FREE! RADIO-TV BOOK AND SAMPLE LESSON!

Send today for National Schools' new, illustrated Book of Opportunity in Radio-Television-

Electronics, and an actual Sample Lesson. No cost—also offered in Spanish and Portuguese—no obligation. Use the coupon now—we'll answer by return airmail.

APPROVED FOR VETERANS AND NON-VETERANS
Check coupon below

Both Resident and Home Study Courses Offered!

NATIONAL SCHOOLS

LOS ANGELES 37, CALIFORNIA • ESTABLISHED 1905
IN CANADA: 811 W. HASTINGS STREET, VANCOUVER, B.C.

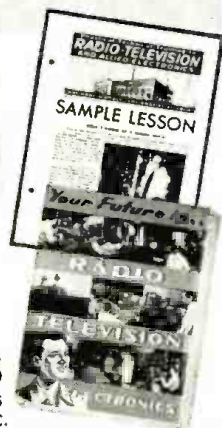

FIND OUT NOW—MAIL COUPON TODAY!

NATIONAL SCHOOLS, Dept. RH-14
4000 South Figueroa Street
Los Angeles 37, California

Mail in envelope or paste on postal card.

Send FREE Radio-TV Electronics book and FREE sample lesson. I understand no salesman will call on me.

NAME _____ AGE _____

ADDRESS _____

CITY _____ ZONE _____ STATE _____

Check here if released from service less than 4 years ago.

Check here if interested in Resident Training at Los Angeles.

The C-800 is here
to bring you new
record performance!



the new
craftsmen 800
FM-AM TUNER
with built-in phono
preamplifier and
record equalizer

Now—Craftsmen brings you a tuner that matches all your finest records . . . is setting new records for versatility, too. The C-800 is further evidence that Craftsman leadership in high fidelity is something you can put your finger on, something you can hear.

- Front-panel-selected equalization for AES, LP or EUROpean recording characteristics. Inverse feedback compensated dual-triode phono preamp for correct turnover and roll-off characteristics.
- Improved AM reception. Wider bandwidth for better fidelity, and sharper IF bandpass "skirts" for greater selectivity.
- Double-shadow tuning eye and AFC (no drift) on FM simplifies tuning. Front-panel AFC cut-out for tuning weak stations.
- Efficient new layout. Bottom plate, completely shielded chassis minimize oscillator radiation, assure tuner isolation.
- Cathode follower audio output for remote installations; 2 volts or less than 1/2% dist. Detector output also has cathode follower for recording applications.
- Bass and treble controls continuously variable from attenuation to boost—flat position clearly marked. Selector positions: FM, FM with AFC, AM, TV, LP, AES, EUR, and SPare.
- Mahogany-finish wood cabinet available.

HIGH FIDELITY—LOW COST! C-400 audio amplifier offers 10 watts \pm 1 db., 15—20,000 cps., less than 1% distortion. New streamlined chassis design.

Write
today for
information

THE RADIO
craftsmen INC.
Dept. R-1, 4401 N. Ravenswood Ave.
Chicago 40, Ill.



Spot Radio News

* Presenting latest information on the Radio Industry.

By RADIO & TELEVISION NEWS'
WASHINGTON EDITOR

A NEW ERA in TV, which many predict will be the most spectacular since the days of the audion, was ushered in during the late fall on the Starlight Roof of the Waldorf-Astoria Hotel in New York City, when before FCC members and its technical staff, and representatives of the television industry, a splashing technical display of compatible color was held.

Through the medium of thirteen color sets, all built to standards set by the National Television System Committee, the possibilities of the compatible system were strikingly displayed. While color intensity varied from chassis to chassis, with some emphasizing reds and yellows, and some producing brilliant colors, others subdued, all agreed that the pictures were faithful enough to be acceptable to the public. Variations were due to adjustment standards adopted by each receiver operator (each company furnished one or more engineers with its set to see that it was installed and operating properly), and hue compromises introduced in the circuitry and allied controls.

For the first time all seven members of the present Commission were in New York to see the test: E. M. Webster, Robert T. Bartley, Robert E. Lee, John C. Doerfer, Frieda Hennock, George E. Sterling, and Rosel Hyde, chairman. They, too, were impressed with the show. Headman Hyde noted that he liked the dress rehearsal very much. (Shortly after, before a conference of business paper editors, Commissioner Doerfer not only declared that he found the test very good, but that as far as he was concerned, he was ready to say *yes* to approval.)

Also on hand to look at color were the ten members of the House Interstate and Foreign Commerce Committee, headed by Charles A. Wolverton who had raved about the results he saw at an earlier show in Princeton: Reps. John W. Heselton, William T. Granaham, Arthur G. Klein, F. Ertel Carlyle, Richard W. Hoffman, Steven B. Derounian, Joseph L. Carrigg, John Bell Williams, and Homer Thornberry. At this test, Congressman Wolverton once more waved the red-green-blue flag, declaring that the only requirement now is prompt approval of the new standards. He noted that there may be a tendency in some official

quarters . . . "to delay approval of the system until all members of . . . industry . . . are lined up . . . in the same competitive position.

"The Communications Act gives no such mandate to the Commission, and it would be singularly unfortunate if it did," he added "because then the private interests of members . . . of industry . . . would become paramount to the public interest."

Other members of Congress were equally enthusiastic. Senator Edwin D. Johnson, the militant color man on the Senate Commerce Committee, told Chairman Hyde, that unless there are some serious flaws in the system and it appears as if there are none, the Commission should act post haste and flash the green light.

THROUGHOUT THE HUGE demonstration room, a remarkable spirit of friendliness among Commissioners and industry, even competitors, obtained. Before the tests, Commissioner Sterling sat down on the floor before one of the color sets, a *Du Mont* model, while Dr. Goldsmith adjusted one of the set's controls, and set-maker prexys, Allen B. Du Mont and Bill Halligan, looked on. Elsewhere in the room, David Sarnoff and William S. Paley, chairmen of the *RCA* and *CBS* boards, arch rivals in the race for color-system acceptance, conversed at some length. Sequential inventor, Peter Goldmark (whose system, approved two years ago, was now being discarded) was also seen chatting amiably with *RCA's* research chief, Elmer Engstrom.

The tests were expensive affairs for industry. *Du Mont* reported that more than \$200,000 worth of experimental gear had been installed in its color studios at 515 Madison Avenue, New York City. Actually much of this equipment has been used during color test studies since '49, officials of the company said. To present ultra-high color signals during its part of the official test, *Du Mont* used universal color scanners. Operating on the principle of flying-spot scanners, the color scanners picked up pictures in the green, red, and blue channels, and fed them to a color encoder. This unit scrambled the channels into a combined signal, containing the necessary color brightness and the proper chro-

RADIO & TELEVISION NEWS



TRAIN **FASTER**—TRAIN **BETTER**—TRAIN **EASIER**
 IN 10 MONTHS—OR LESS—FOR
RADIO-TELEVISION

Our 21st Year Training Men for Greater Incomes and Security in Radio-Television

I SEND YOU
18 BIG KITS

of Radio-Television parts and equipment. Much of your training will be actual construction and experimentation . . . the kind of truly PRACTICAL instruction that prepares you for your Radio-Television career.



Frank L. Sprayberry
 President
 Sprayberry Academy
 of Radio

NEW! NO OBLIGATION PLAN

You Have No Monthly Payment Contract to Sign
 Pay For Your Training as You Earn and Learn

You can get into Radio-Television, today's fastest growing big money opportunity field, in *months* instead of years! My completely new "package unit" training plan prepares you in as little as 10 months or even less! *No monthly payment contract to sign—thus NO RISK to you!* This is America's finest, most complete, practical training—gets you ready to handle any practical job in the booming Radio-Television industry. Start your own profitable Radio-Television shop . . . or accept a good paying job. I have trained hundreds of successful Radio-Television technicians during the past 21 years—and stand ready to train you, even if you have no previous experience! Mail coupon and get all the facts—FREE!



Valuable Equipment Included With Training

The new Sprayberry "package" plan includes many big kits of genuine, professional Radio-Television equipment. You perform over 300 demonstrations, experiments and construction projects. You build a powerful 6-tube 2-band radio set, multi-range test meter, signal generator, signal tracer, many other projects. All equipment and lessons are *yours to keep* . . . you have practically everything you need to set up your own profitable Radio-Television service shop.

Earn Extra Money While You Learn!

All your 10 months of training is IN YOUR HOME in spare hours. Keep on with your present job and income while learning. With each training "package" unit, you receive extra plans and "Business Builder" ideas for spare time Radio-Television jobs. New television stations everywhere, open vast new opportunities for trained Radio-Television Technicians—and those in training. If you expect to be in the armed forces later, there is no better preparation than practical Sprayberry Radio-Television training.

YOU BUILD

the Television set and the powerful superhet radio receiver shown above IN ADDITION to the other test units shown here (many are not shown because of lack of space). All equipment I send you is **YOURS TO KEEP.**

Approved for Veterans under the G. I. Bill

SPRAYBERRY ACADEMY OF RADIO 111 NORTH CANAL ST.
 Dept. 25-E, Chicago 6, Ill.

**MAIL COUPON
 TODAY!
 NO OBLIGATION**

I invite you to get all the facts—
**FREE TO YOU 3 BIG
 RADIO-TELEVISION BOOKS**

I want you to have ALL the facts about my new 10-MONTH Radio-Television Training—without cost! Rush coupon for my three big Radio-Television books: "How to Make Money in Radio-Television." PLUS my new illustrated Television Bulletin PLUS an actual sample Sprayberry Lesson—ALL FREE. No obligation and no salesman will call. Mail coupon NOW!

SPRAYBERRY ACADEMY OF RADIO, Dept. 25-E
 111 North Canal St., Chicago 6, Ill.

Please rush to me all information on your 10-MONTH Radio-Television Training Plan. I understand this does not obligate me and that no salesman will call upon me. Be sure to include 3 books FREE.

Name..... Age.....

Address.....

City..... Zone..... State.....



"Of the very best!"

—HIGH FIDELITY MAGAZINE

FISHER

SERIES "50"

■ It is only natural that more than one manufacturer will claim *his* product is the best. For that reason it remains for *you* to be the judge. We say—*demand the specs.* Then check workmanship, performance and beauty of appearance. If you do all these things, the answer will inevitably be . . . THE FISHER SERIES "50." There is no finer made.

THE FISHER Master Audio Control MODEL 50-C

■ "One of the finest units yet offered to the enthusiast or audio engineer."
—*Radio and TV News.* Can be used with *any* amplifier. IM distortion virtually unmeasurable. Complete, professional equalization settings and tone controls; genuine F-M loudness control; five inputs, five independent input level controls, two cathode follower outputs. Self-powered.

Chassis, \$89.50 • With blonde or dark cabinet, \$97.50

THE FISHER FM-AM Tuner MODEL 50-R 70-RT

■ Features *extreme sensitivity* (1.5 mv for 20 db of quieting); *low distortion* (less than 0.04% for 1 volt output); *low hum* (more than 100 db below 2 volts output.) Armstrong system, *adjustable AFC* with switch, *adjustable AM selectivity*, separate FM and AM front ends (shock-mounted), cathode follower output, fully shielded, aluminum chassis, self-powered. \$164.50

Model 70-RT, same as Model 50-R, but including tone controls, phono-graph preamplifier-equalizer, and loudness balance control. \$184.50

THE FISHER 50-Watt Amplifier MODEL 50-A

■ Truly the world's finest all-triode amplifier, yet moderately priced. A man's size unit! Less than 1% distortion at 50 watts (.08% at 10 watts.) IM distortion below 2% at 50 watts. Uniform response within .1 db from 20 to 20,000 cycles; 1 db, 5 to 100,000 cycles. Hum and noise more than 96 db below full output. Quality components throughout. \$159.50

Prices slightly higher west of the Rockies

WRITE TODAY FOR COMPLETE SPECIFICATIONS

FISHER RADIO CORPORATION • 39 EAST 47th STREET • N. Y.

minance or color content. The combined signal was then fed to the u.h.f. transmitter.

According to *RCA*, nearly \$2-million has been spent in equipping the Colonial Theatre with equipment, lighting and air conditioning gear for colorcasts. An involved thyatron power control, installed to provide faithful translation of light for sets and performers, was said to have cost nearly a half-million dollars. It was from this costly installation that a half-hour color show was broadcast during the Waldorf demonstration. For reception, three antennas were located on the twenty-first floor of the hotel; these antennas were tuned to pick up channels 2, 4, and u.h.f. (708-714 mc.). For u.h.f. an ultra-high converter was used. It was inserted ahead of a distribution amplifier to convert the high-frequency signals down to channel 6. An interesting setup was also used during a closed-circuit test, involving coax cable and microwave-relay transmission. In this instance, signals originating from the Colonial Theatre were transmitted to the *NBC* control room on a local telephone circuit, and for the radio relay, the signal was then sent from this control room to the control room of the telephone company. For coax sending, the signal had to be modified by color conversion equipment, which reduced the color subcarrier frequency from 3.6 to 2.4 megacycles. The radio-relay facilities comprised about 540 route miles specially equalized for color. On the coax run, about 500 miles of cable were involved.

The NTSC system has won the wholehearted approval of *CBS*, too. Prexy of *Columbia* told network affiliates that . . . "color is here." And *CBS'* engineering vice-president, Bill Lodge, added that they are satisfied that . . . "NTSC color will gradually move into American homes . . . and we want to move in with it." The new color system is basically sound, he added, and *CBS* intends to spend . . . "several million dollars in facilities and in broadcasting during the initial growth period."

Describing how far *CBS* has gone, even at this point, in making . . . "the NTSC system not an abstract, not an engineer's dream, but a practical reality . . ." the station's prexy noted that they had developed new pickup equipment, featuring a chromacoder and allied camera. This system, it was said, involves use of a camera employing a field-sequential technique, similar to that used in the earlier setup by *Columbia*. Then a coding unit changes the signal into one which meets NTSC standards. This camera uses but one image orthicon instead of three. *CBS* experts outlined, and thus initial equipment costs will be less using this method, networkers were told.

Commenting on the progress made in their camp, *RCA's* Ted Smith, engineering-products vice-president, de-

(Continued on page 146)



J. E. SMITH
President
National Radio
Institute
Washington, D. C.
40 years of success
training men at
home in spare time.

I Will Train You at Home

For Good Pay Jobs, Success in

RADIO-TELEVISION



Practice Broadcasting with Equipment I Send

As part of my Communications Course I send you kits of parts to build the low-power Broadcasting Transmitter shown at the left. You use it to get practical experience putting a station "on the air," performing procedures demanded of Broadcasting Station Operators. An FCC Commercial Operator's License can be your ticket to a better job and a bright future; my Communications Course gives you the training you need to get your license. Mail card below and see in my book other valuable equipment you build.

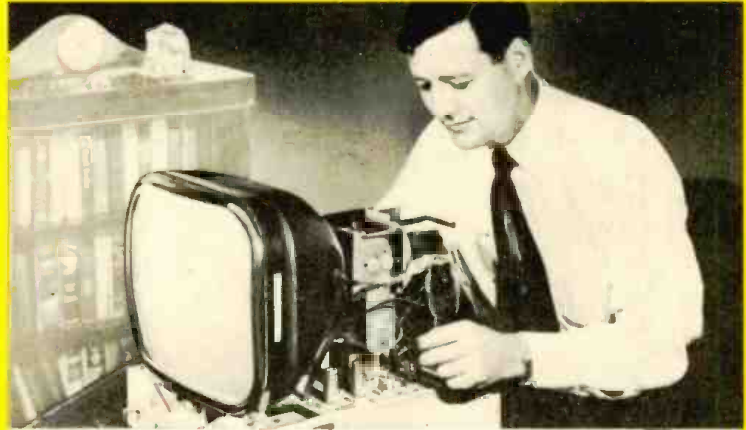

Practice Servicing with Equipment I Send

Nothing takes the place of PRACTICAL EXPERIENCE. That's why NRI training is based on LEARNING BY DOING. You use parts I furnish to build many circuits common to Radio and Television. With my Servicing Course you build a modern Radio (shown at right). You build a Multitester which you use to help fix sets while training. Many students make \$10, \$15 a week extra fixing sets in spare time starting a few months after enrolling. All equipment is yours to keep. Card below will bring book showing other equipment you build.

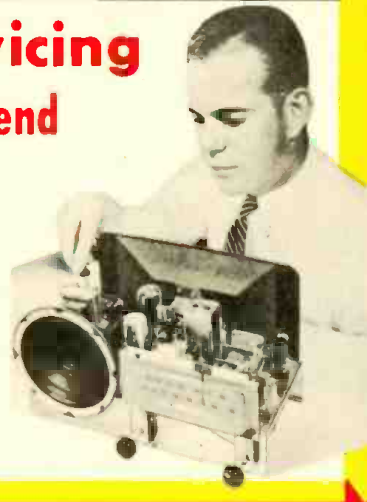
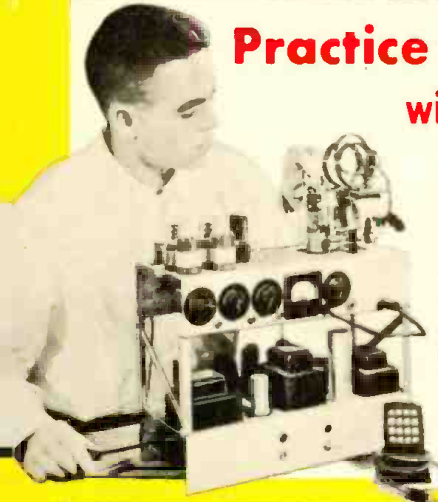

Television is Growing Fast Making New Jobs, Prosperity

More than 25 million homes now have Television sets and thousands more are being sold every week. Well trained men are needed to make, install, service TV sets. About 200 television stations on the air with hundreds more being built. Think of the good job opportunities here for qualified technicians, operators, etc. If you're looking for opportunity get started now learning Radio-Television at home in spare time. Cut out and mail postage free card. J. E. Smith, President, National Radio Institute, Washington, D. C. OUR 40TH YEAR.

AVAILABLE TO
VETERANS
UNDER G.I. BILL

**Good Jobs, Good Pay, Success
in Radio-TV! SEE OTHER SIDE**

CUT OUT AND MAIL THIS CARD NOW

Sample Lesson & 64-Page Book

Both FREE

This card entitles you to Actual Lesson on Servicing, shows how you learn Radio-Television at home. You'll also receive my 64-Page Book, "How to Be a Success in Radio-Television." Mail card now!

NO STAMP NEEDED! WE PAY POSTAGE

Mr. J. E. SMITH, President,
National Radio Institute, Washington 9, D. C.

Mail me Lesson and Book, "How to Be a Success in Radio-Television." (No Salesman will call. Please write plainly.)

NAME AGE

ADDRESS

CITY ZONE STATE

VETS write in date of discharge

B C D

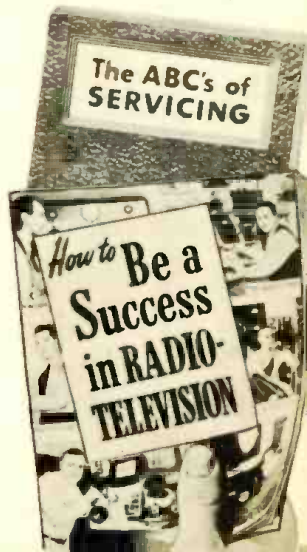

Train at Home to Jump Your Pay as a RADIO-TV Technician



J. E. Smith, President
National Radio Institute

The men whose messages are published below were not born successful. Not so long ago they were doing exactly as you are now... reading my ad! They decided they should KNOW MORE... so they could EARN MORE... so they acted! Mail card below now.

Get a Better Job—Be Ready for a Brighter Future in America's Fast Growing Industry

Training PLUS opportunity is the PERFECT COMBINATION for job security, good pay, advancement. When times are good, the trained man makes the BETTER PAY, GETS PROMOTED. When jobs are scarce, the trained man enjoys GREATER SECURITY. NRI training can help assure you and your family more of the better things of life.

Radio-Television is today's opportunity field. Even without Television, Radio is bigger than ever before. Over 3,000 Radio Broadcasting Stations on the air; more than 115 million home and Automobile Radios are in use. Then add Television. Television Broadcast Stations extend from coast to coast now with over 25 million Television sets already in use. There are channels for 1,800 more Television Stations. Use of

Aviation and Police Radio, Micro-Wave Relay, Two-way Radio communication for buses, taxis, trucks, etc. is expanding. New uses for Radio-Television principles coming in Industry, Government, Communications and Homes.

My Training is Up-to-Date You Learn by Practicing

Get the benefit of my 40 years experience training men. My well-illustrated lessons give you the basic principles you must have to assure continued success. Skillfully developed kits of parts I furnish "bring to life" the principles you learn from my lessons. Read more about equipment you get on other side of this page.

Naturally, my training includes Television. I have, over the years, added more and more Television information to my courses. The equipment I furnish students gives experience on circuits common to BOTH Radio and Television.

Find Out About the Tested Way to Better Pay

Read at the right how just a few of my students made out who acted to get the better things of life. Read how NRI students earn \$10, \$15 a week extra fixing Radios in spare time starting soon after enrolling. Read how my graduates start their own businesses. Then take the next step—mail card below.

You take absolutely no risk. I even pay postage. I want to put an Actual Lesson in your hands to prove NRI home training is practical, thorough. I want you to see my 64-page book, "How to Be a Success in Radio-Television" because it tells you about my 40 years of training men and important facts about present and future Radio-Television job opportunities. You can take NRI training for as little as \$5 a month. Many graduates make more than the total cost of my training in two weeks. Mailing postage free card can be an important step in making your future successful. J. E. Smith, President, National Radio Institute, Washington 9, D. C. OUR 40TH YEAR.

I TRAINED THESE MEN



Handicapped but Successful

"I am now Chief Engineer at WHAW. My left hand is off at the wrist. A man can do... if he wants to." R. J. Bailey, Weston, W. Va.



\$10 a Week In Spare Time

"Before finishing, I earned as much as \$10 a week in Radio servicing. In my spare time, I recommend NRI." S. J. Petrucci, Miami, Fla.

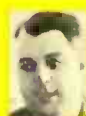

Control Operator, Station WEAN

"I received my license and worked on ships. Now, with WEAN as control operator, NRI course is complete." R. Arnold, Rumford, R. I.



Has Own Radio-Television Shop

"Doing Radio and Television servicing full time. Have my own shop. I owe my success to NRI." Curtis Stath, Fort Madison, Iowa.



Has Growing Business

"Am becoming expert Teletician as well as Radiotriician. Without your course this would be impossible." P. Brogan, Louisville, Ky.



Got First Job Thru NRI

"My first job was with KDLR. Now Chief Engr. of Radio Equipment for Police and Fire Dept." T. Norton, Hamilton, Ohio.

Find Out What RADIO-TV Offers You



SAMPLE LESSON and 64-PAGE BOOK Both FREE

Cut out and mail postage-free card today!

Start Soon to Make \$10, \$15 a Week Extra Fixing Sets

Keep your job while training. Many NRI students make \$10, \$15 and more a week extra fixing neighbors' Radios in spare time starting a few months after enrolling. I start sending you special booklets that show you how to fix sets the day you enroll. The multitester you build with parts I furnish helps discover and correct troubles.



Do You Want Your Own Business?

Many NRI trained men start their own successful Radio-Television sales and service business with capital earned fixing Radios in spare time. My book tells how you can be your own boss. Joe Travers, a graduate of mine, in Asbury Park, N. J., writes: "I've come a long way in Radio and Television since graduating. Have my own business on Main Street."



NRI Training Leads to Jobs Like These

BROADCASTING
Chief Technician
Chief Operator
Power Monitor
Recording Operator
Remote Control Operator

SERVICING
Home and Auto Radios
P. A. Systems
Television Receivers
Electronic Controls
FM Radios

IN RADIO PLANTS
Design Assistant
Transmitter Design Technician
Service Manager
Tester
Serviceman
Research Assistant

SHIP AND HARBOR RADIO
Chief Operator
Assistant Operator
Radiotelephone Operator

GOVERNMENT RADIO
Operator in Army, Navy, Marine Corps, Coast Guard
Forestry Service
Dispatcher
Airways Radio Operator

AVIATION RADIO
Plane Radio Operator
Transmitter Technician
Receiver Technician
Airport Transmitter Operator

TELEVISION
Pick-up Operator
Voice Transmitter Operator
Television Technician
Remote Control Operator
Service and Maintenance Technician

POLICE RADIO
Transmitter Operator
Receiver Serviceman

FIRST CLASS
Permit No. 20-R
(Sec. 34.9, P.L. & R.)
Washington, D.C.

BUSINESS REPLY CARD

No Postage Stamp Necessary If Mailed In The United States

POSTAGE WILL BE PAID BY
NATIONAL RADIO INSTITUTE
16th and U Sts., N.W.
Washington 9, D. C.

NEW Certified Quality Service Business Builders SIGNS...POSTALS ...AD MATS

GET THIS CATALOG →

TIE IN even stronger with your *Certified Quality Service* campaign in LIFE and POST. Tell your customer again and again. *You* offer him the quality service and fair charges that spell C...Q...S. Win his confidence and you win his business. Along with your CQS tags and displays, use your new CQS illuminated indoor sign . . . flange sign . . . postals . . . and ad mats. You'll be proud of them. They are modern, dignified, economical . . . and their CQS message sells *hard*. See them at your CBS-Hytron distributor's. Or write for CQS-10 catalog. But act now!



NEED MORE CQS TAGS?

With your 3-line imprint, they are priced low: 250 for \$2.25, 500 for \$3.50, 1000 for \$6.00. Order from your distributor . . . or direct.

4 MORE CQS Sales Aids

IDENTIFY YOU AS A...
Certified
QUALITY SERVICE DEALER

Tie in even stronger with your *Certified Quality Service Plan*. With your CBS-Hytron sponsored advertising campaign in LIFE and the POST. With your CQS Kit: Tags . . . decal . . . window streamer . . . and LIFE-POST' esel display. Tell your customer again and again that you offer the *Certified Quality Service* he wants. The quality service and parts . . . the fair charges . . . the technical know-how and equipment that spell C...Q...S. Win his confidence . . . and you will gain more business . . . more profits. Use your 4 new CQS sales outdoers:

NEW CQS ILLUMINATED INDOOR SIGN
Wraps your potent *Certified Quality Service* message into a dignified package you will be proud to display. Brilliant . . . colorful . . . Plexiglas sign (25½ by 10 by 3½ inches) pulls customers to you. Hang it (comes equipped with chains and hooks) or stand it in window . . . on counter . . . on shelf. Comes ready to plug into a-c socket, with economical 20-watt fluorescent tube. Makes ideal night light and 24-hour salesman identify yourself. Get your CQS illuminated indoor sign up right away. Only \$9.45, F.O.B. continental U. S. A.; or see your CBS-Hytron distributor.

RADIO...TELEVISION
Certified QUALITY SERVICE
We Certify Quality Parts and Service... Fair Charges
TUBES

NEW CQS METAL FLANGE
Proudly, boldly seen by millions in campaign big, sturdy by 12 inches, with complete with mounting colors in weather-resistant. Mount this smart sign outdoors or in U. S. A.; or see your distributor.

NEW CQS POSTAL CARDS
NEW CQS AD MAT

CQS-10 PA-13

→ CQS-10 Catalog also features
3 direct-mail postals . . . 9 ad mats.

60-DAY OFFER!

10 SOCKET LOCATORS with 20 miniature tubes



During January and February. Order 20 CBS-Hytron miniature tubes. Your distributor will *give* you this package of 10 new CBS-Hytron Socket Locators. With them, plugging miniatures into hard-to-locate sockets is easy. Socket Locator slips over pins of tube (7-pin or 9-pin). Key of Locator finds socket . . . guides tube into it, quickly. Save time and temper . . . take advantage of this limited offer. See your CBS-Hytron distributor.

NEW...FREE CBS-HYTRON CRYSTAL DIODE MANUAL

Complete, down-to-earth, 8-page manual on crystal diodes. Three parts: 1. Advantages and construction. 2. Complete data. 38 types. 3. Selection and application. Profusely illustrated. Ten basic circuits. Gives you *all* the crystal-diode information you have been seeking. FREE . . . from your CBS-Hytron distributor . . . or write direct.

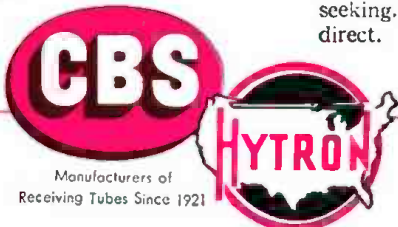

CBS-HYTRON Main Office: Danvers, Massachusetts

A Division of Columbia Broadcasting System, Inc.

A member of the CBS family . . . CBS Radio • CBS Television
Columbia Records, Inc. • CBS Laboratories • CBS-Columbia • and CBS-Hytron

RECEIVING . . . TRANSMITTING . . . SPECIAL-PURPOSE AND TV PICTURE TUBES • GERMANIUM DIODES AND TRANSISTORS
January, 1954

Introducing

The New SYLVANIA TELEVISION LABORATORY OSCILLOSCOPE Type 404

An extremely sensitive, wide band, all-purpose oscilloscope created especially for designing and servicing television receivers.

✓ ENGINEERED BY SYLVANIA

Sylvania's extensive engineering facilities have made possible the development of an instrument which you can depend upon to help you service quickly and accurately.

✓ STYLED BY SUNDBERG AND FERAR

The striking professional appearance of the 404 Oscilloscope helps you win more service business by inspiring customer confidence in your ability to do a top-notch job.



CHECK THESE FEATURES

- ✓ Flat response from 10 cycles to 2 mc., useful to 4 mc.
- ✓ Sensitivity—0.01 volts (10 millivolts per inch)
- ✓ Input Impedance—5.0 megohms and 26 uufd.
- ✓ Unusual sync stability
- ✓ Frequency-compensated attenuator
- ✓ Vertical and horizontal polarity reversing switches
- ✓ High voltage and demodulator probes included with instrument

Available now through your SYLVANIA Radio Tube Distributor

SYLVANIA ELECTRIC PRODUCTS INC.
RADIO AND TELEVISION DIVISION
Williamsport, Pennsylvania



NO EXPERIENCE NECESSARY! LEARN TELEVISION AT HOME IN YOUR SPARE TIME!

L. C. Lane, B.S., M.A.
President: Radio-Television Training Association
Executive Director: Pierce School of Radio & Television

Super-Het Radio Receiver

Public Address System

C-W Telephone Transmitter

AC-DC Power Supply

Giant Screen TV Receiver

Combination Voltmeter-Ammeter-Ohmmeter

RF Signal Generator



You build all this equipment and more! Everything yours to keep.

VETERANS! CIVILIANS! PREPARE FOR A BRIGHTER FUTURE AS A TRAINED TV TECHNICIAN!

Thousands of new jobs in TV are opening up in every state as new stations go on the air. You too can take your place in America's booming TELEVISION and Electronics industries... enjoy the success and happiness you always wanted. Keep your present job while I prepare you at home for a life-time career as a trained TV Technician. You "learn-by-doing" with the actual parts and equipment I send you... the same successful methods that have helped hundreds of men—many with no more than grammar school training—master television!

ENOUGH EQUIPMENT TO SET UP YOUR HOME LABORATORY!

As part of your training, I give you ALL the equipment you need to prepare for a BETTER PAY TV job. You build and keep a professional GIANT SCREEN TV RECEIVER complete with big picture tube (designed and engineered to take any size up to 21-inch)... also a Super-Het Radio Receiver, RF Signal Generator, Combination Voltmeter-Ammeter-Ohmmeter, C-W Telephone Transmitter, Public Address System, AC-DC Power Supply. Everything supplied including all tubes.

GOOD SPARE TIME EARNINGS!

Almost from the very start you can earn extra money while learning, repairing Radio-TV sets for friends and neighbors. Many of my students earn up to \$25 a week... pay their entire training from spare time earnings... start their own profitable service business. Act now! Mail coupon and find out for yourself what a TV career can do for you!

VETERANS!

MY SCHOOLS FULLY APPROVED TO TRAIN VETERANS UNDER NEW G.I. BILL! If discharged after June 27, 1950—CHECK COUPON! Also approved for RESIDENT TRAINING in New York City... qualifies you for full subsistence allowance up to \$160 per month.

EXPERT FM-TV TECHNICIAN TRAINING!

My FM-TV Technician Course can save you months of training if you have previous Armed Forces or civilian radio experience! Train at home with kits of parts, plus equipment to build BIG SCREEN TV RECEIVER, and FREE FCC Coaching Course! ALL FURNISHED AT NO EXTRA COST!

NEW! PRACTICAL TV CAMERAMAN & STUDIO COURSE!



(For men with previous radio & TV training)

I train you at home for an exciting big pay job as the man behind the TV camera. Work with TV stars in TV studios or "on location" at remote pick-ups! A special one-week course of practical work on TV studio equipment at Pierce School of Radio & TV, our associated resident school in New York City, is offered upon your graduation.

FREE FCC COACHING COURSE!

QUALIFIES YOU FOR HIGHER PAY! Given to all my students AT NO EXTRA COST after TV Theory and Practice is completed. Helps you qualify for the TOP JOBS in Radio-TV that demand an FCC License! Full training and preparation at home for your FCC License.

OPTIONAL: TWO WEEKS TRAINING IN NEW YORK CITY AT NO EXTRA COST

You get two weeks, 50 hours, of intensive Laboratory work on modern electronic equipment at our associated school in New York City—Pierce School of Radio and Television. And I give you all this AT NO EXTRA COST whatsoever, after you finish your home study training in the Radio-FM-TV Technician course and FM-TV Technician Course.

RADIO-TELEVISION TRAINING ASSOCIATION

52 East 19th Street, New York 3, N. Y.

Licensed by the State of New York

Approved by the VA

MAIL COUPON TODAY!

MY 4 FREE AIDS SHOW YOU HOW AND WHERE TO GET A BETTER PAY JOB IN TELEVISION! See for yourself how my simple, practical methods make success easy.



NO SALESMAN WILL CALL!

Mr. Leonard C. Lane, President
RADIO-TELEVISION TRAINING ASSOCIATION
52 East 19th Street, New York 3, N. Y. Dept. T-1B

Dear Mr. Lane: Mail me your NEW FREE BOOK, FREE SAMPLE LESSON, and FREE aids that will show me how I can make BIG MONEY IN TELEVISION. I understand I am under no obligation and no salesman will call.

(PLEASE PRINT PLAINLY)

NAME _____ AGE _____

ADDRESS _____

CITY _____ ZONE _____ STATE _____

I AM INTERESTED IN:

- Radio-FM-TV Technician Course
 FM-TV Technician Course
 TV Cameraman & Studio Course
- VETERANS!** Check here for Training under NEW G.I. Bill

proudly announces

TRIO

"TWIN-SIX"

(A significant addition to the Zig-Zag line)

The New ZIG-ZAG

... the greatest advance ever made in ALL-CHANNEL antenna design!

Not content to bring out just another all-channel antenna, TRIO studied and tested every other model available. Months of research produced the "Twin-Six", a Zig-Zag that provides all of the desirable features indicated above. Quantitative ratings for antennas are practically meaningless because of some exaggerated claims. For this reason, the "Twin-Six" is announced without the usual gain charts. The new "Twin-Six", however, equals and, in most cases, greatly exceeds the gains of these antennas on every channel. For instance, the "Twin-Six" showed a 2 to 6 db higher gain than a competitive antenna which is advertised as having a 12 db gain.

MINUTE-UP ASSEMBLY

There's no antenna easier to assemble. Shipped with all hardware mounted on the boom. Complete assembly consists of matching elements to color coded insulators and snapping on spring clips. Improper assembly impossible.



Insulators come mounted on boom and are so designed that "shorting-out" is impossible. Antenna elements mounted merely by snapping on the spring clips.

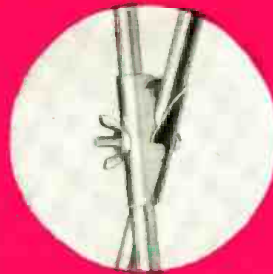

Pre-assembled high channel elements are swung into position and quickly locked by mating brackets.

NEW ZIG-ZAG "TWIN-SIX" OFFERS:

Measurable Higher Gain On All VHF Channels Than Any Other Single Bay All-Channel Antenna

PLUS

1. One Horizontal Bay Does It All!
2. Single Lead-In Operation!
3. Easy-Up, One Minute Assembly!
4. Rugged Construction Throughout — No Droop, No Sag! Light Weight — Attractive Appearance!
5. UHF Reception For All Primary Areas!
6. Low Standing Wave Ratio!
7. Built and Backed by TRIO — A Name You Can Trust!
8. Competitively Priced!



TRIO

MANUFACTURING CO. GRIGGSVILLE, ILL.



Team the new Zig-Zag "Twin-Six" with the dependable TRIO rotator for the maximum in TV enjoyment!



Bag these capacitors ...without hunting

These new Centralab Ceramic tubular and disc BC Capacitor Kits end parts hunting. With parts at your finger-tips, you save unnecessary trips... you stay in the shop and build more profit time.



Each assortment has been completely revised to keep pace with the rapidly changing electronics field.

Kit DK-200, for example, contains 200 tubulars and discs in 31 fast-moving types. All parts are sealed in envelopes. You pay nothing extra for handy metal cabinet.



Pocket-sized KIT DK-100 contains 100 tubulars and discs in 5 most popular values. Box is free.

Other Kits of 12 and 25 Hi-Kaps are values you use every day for TV and radio.

See your Centralab distributor NOW for complete facts on BC Capacitor Kits. You'll be time and money ahead if you do.



Centralab

CENTRALAB,
A Division of Globe-Union Inc.
910-A E. Keefe Ave., Milwaukee 1, Wis.

Please rush complete technical data on Centralab's Ceramic Capacitor Kits.

Name.....

Firm.....

Address.....

City.....Zone.....State.....

Within the INDUSTRY

R. H. ENGSTROM, former senior electronics buyer for *Zenith Radio Corporation*, has been named sales manager of *Dale Products, Inc.*, Columbus, Nebraska manufacturer of wirewound and deposited carbon resistors.



Mr. Engstrom has had 12 years' experience in radio parts buying and sales for *Zenith* and *Motorola*.

The company also named M. A. Woodworth to the post of comptroller. He was formerly with the auditing department of the *Nebraska Public Power System*.

* * *

CHARLES C. KAYHART has been named service training director for *The Magnavox Company*. He will make his headquarters at the company's Fort Wayne, Ind. plant... *DeWald Radio Mfg. Corp.* has appointed **JAMES N. RYAN, JR.** to the post of sales and advertising manager... **WILLIAM H. KELLEY** has been named to the newly-created post of vice-president in charge of marketing for *Allen B. Du Mont Laboratories, Inc.* He was formerly a vice-president of *Motorola, Inc.*...

EDWARD J. DAVENPORT is the new chief of the cathode-ray tube commercial engineering division of *National Union Radio Corporation*... **DAN D. HALPIN**, general sales manager of the television receiver division of *Allen B. Du Mont Laboratories, Inc.*, has been named chairman of the sales managers committee of RETMA. He succeeds William L. Dunn in the post... **GORDON S. HUMPHREY**, executive assistant to the general manager of *Raytheon Manufacturing Company's* equipment division, has been appointed assistant vice-president of the company... **JOSEPH S. ROBB** is the new director of engineering for *Radio Condenser Company* and will be in charge of all radio condenser engineering functions... **DONALD H. STOVER**, former district service manager for the *RCA Service Company, Inc.*, has been appointed service manager at *Sentinel Radio Corporation*... *Pacific Transformers, Inc.* has appointed **WILLIAM HERRON** to the post of West Coast sales engineer... **DR. ADAIR MORRISON** has been named head of the research section of *Sprague Electric Company's* research and engineering department... **MARTIAL A. HONNELL** was recently elected vice-president and chief engineer of *Measurements Corporation* of Boonton, N. J. ... **HARRY E. ALLEN** has been promoted from senior engineer to government products manager of the *Jensen Man-*

ufacturing Company of Chicago... *Raytheon* has named **STANLEY D. CRANE** to the post of director of engineering and research for the special products division of the television and radio division... **J.E. SCHLENER** is the new merchandising manager of the electronics division of *Sylvania Electric Products Inc.* He will make his headquarters in Woburn, Mass... **EDMOND S. WINLUND** is the new chief engineer for *Gray Research and Development Co., Inc.* He was formerly associated with *RCA* and *Westinghouse*... **WALTER D. ROWLANDS**, founder and president of *Major Appliances, Inc.* of Florida passed away recently after an illness of two months. His widow has been named to succeed him... **JOHN S. MARGOLIN** and **WILL BROOKS** have joined the rep firm of *J.K.M. Inc.* in Chicago. Both men were formerly associated with *Tape Master, Inc.*... **ROBERT L. SHAW** is the new radio field sales manager for the radio and television division of *Sylvania*.

* * *

JACK COLVIN has been named director of engineering for the *Gates Radio Company* succeeding the late Fred O. Grimwood.



Prior to joining *Gates*, Mr. Colvin was chief engineer and plant manager of the *Commercial Radio Company* of New York, chief audio engineer for the *American Broad-*

casting Company, and systems engineer for the *Radio Corporation of America*.

Mr. Francis W. Wentur, the company's chief engineer who has been handling the director's post, will now devote his full time to his regular duties.

* * *

SYLVANIA ELECTRIC PRODUCTS INC. has broken ground for a new TV picture tube plant at Fullerton, California, 30 miles southeast of Los Angeles. The building, which should be ready for occupancy about April 1st, has 51,000 square feet of floor space... The Carboly Department of **GENERAL ELECTRIC COMPANY** has opened a new magnet plant in Edmore, Michigan. The plant employs about 450 persons... **RADIO CONDENSER COMPANY** has placed in operation part of its new 90,000 square foot manufacturing plant in Camden, N. J... **PACKARD-BELL COMPANY** formally opened two new buildings housing its cabinet milling and finishing division in the West Los Angeles area... **PYRAMID ELECTRIC CO.** has opened a new plant in Gas-

NO ROTORMOTOR-YET

ALL DIRECTION UHF-VHF RECEPTION

53 CLAIMS GRANTED IN 5 U. S. PATENTS

#2,585,670
 #2,609,503
 #2,625,655
 #2,644,091
 #2,661,423
 OTHERS PENDING

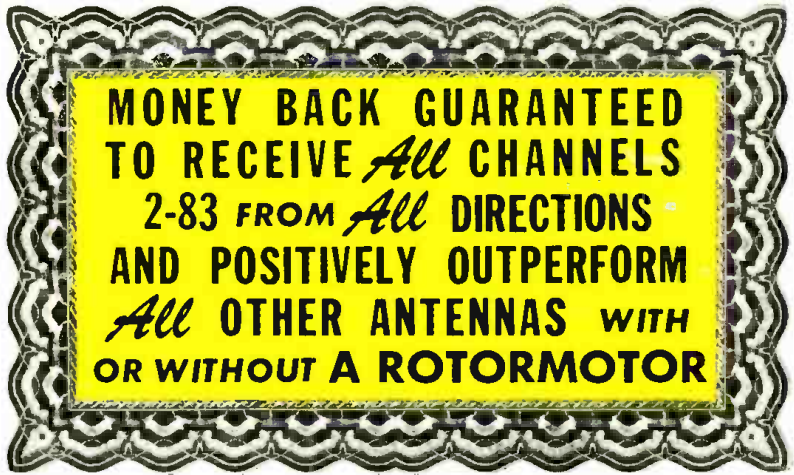

**MONEY BACK GUARANTEED
 TO RECEIVE *All* CHANNELS
 2-83 FROM *All* DIRECTIONS
 AND POSITIVELY OUTPERFORM
All OTHER ANTENNAS WITH
 OR WITHOUT A ROTORMOTOR**

Guaranteed
 60 mi UHF
 60 mi VHF

SUPER 60

UP TO

LIST PRICE
\$36.75
 SEE YOUR
 JOBBER

UP TO

**10 TIMES MORE POWERFUL
 THAN ALL OTHER ANTENNAS**
Solves Your Problem in Your Area

Guaranteed
 40 mi UHF
 40 mi VHF

SUBURBAN 40

LIST PRICE
\$24.50
 SEE YOUR
 JOBBER

The Super 60 is the general purpose model for conditions prevailing in most communities today. Within a short time 15 to 20 UHF-VHF stations will be on the air within a 60 mile radius of every fair sized community. With the installation of the Super 60, you are improving your present reception in all directions and you are ready for the future.

The Suburban 40 has been developed for suburban areas where the stations are closer and trouble with distance is less of a problem — but the advantage of all direction all channel reception is necessary. A low priced high quality antenna for the present and the future.

Here is the real go-getter of the All Channel family. The Ultra 150 reaches out at long distances on VHF and gives you a bright, clear picture 150 miles and more. This antenna has solved the problem for thousands throughout the country where long range reception was otherwise impossible.

**9 POSITION
 ELECTRONIC
 ORIENTATION
 SWITCH**



PRICE INCLUDES

Antenna arrays - necessary stacking bars - 9 position switch - switch-to-set coupler - necessary hook-up harness - 7 1/2" stand-offs. Individually boxed in mailable carton.

NEW POLYMICALENE
 4 CONDUCTOR TRANSMISSION LINE

- Low Loss External Air Dielectric
- Matched Impedance
- Eliminates End Sealing
- Eliminates Condensation
- Up to 50% Less Loss Than Tubular When Wet
- Easily Spiraled
- No Breaking or Shorting
- Patents Pending - T. M. Reg.

Guaranteed
 100 mi VHF
 30 mi UHF

ULTRA 150

LIST PRICE
\$43.50
 SEE YOUR
 JOBBER

While antenna reception is guaranteed as specified, perfect pictures have been consistently received from 2 to 3 times these distances.

ALL CHANNEL ANTENNA CORP.

70-07 Queens Blvd., Woodside 77, N. Y.

Hickory 6-2304

Sangamo
top Quality
Capacitors
 since
1924

First
 molded wire lead
 mica

Complete line
 for all requirements

First molded paper tubular

Developer of
HUMIDITITE

Look to Sangamo—the fastest growing capacitor manufacturer in America—for top quality capacitors at a fair price. The line includes wire lead micas, silvered button micas, molded paper tubulars, oil filled paper capacitors, dry electrolytics, tantalum electrolytics. Write for Engineering Data Sheets on the types you need.

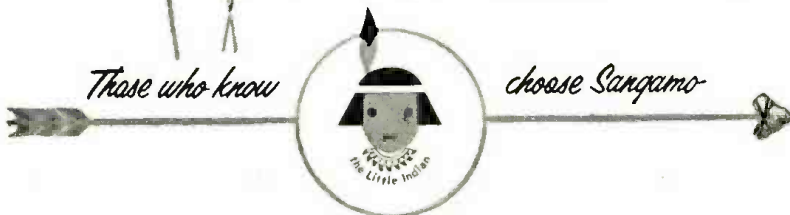

SANGAMO ELECTRIC COMPANY

MARION, ILLINOIS

tonia, N. C. for the manufacture of paper, motor starting, and ceramic condensers. The plant occupies 160,000 square feet of floor space . . . Increased manufacturing facilities at **GENERAL ELECTRIC'S** receiving tube plant at Tell City, Ind. will be housed in a newly-completed 44,000 square foot plant addition. Component parts and mounts for receiving tubes will be processed in the new addition . . . **THE MORRIS F. TAYLOR CO.** has moved to larger quarters at 9431 Georgia Ave., Silver Spring, Maryland. The move was necessitated by a fire which almost destroyed the firm's previous location in the Westland building . . . Ground has been broken for an addition to **STROMBERG-CARLSON'S** electronics engineering building which will triple the size of the firm's facilities for that department . . . **TRAD TELEVISION CORPORATION** of Asbury Park, N. J. has resumed full production with the dedication of a three-story wing replacing that part of the plant which was destroyed by fire a year ago . . . **WALDOM ELECTRONICS, INC.** has begun construction of a modern plant at 4621-4645 W. 53rd Street, Chicago . . . **NEWARK ELECTRIC COMPANY** has added 10,000 square feet of floor space by taking over another floor of its building at 223 W. Madison St. in Chicago . . . **GEO. STEVENS MANUFACTURING CO., INC.** of Chicago has completed an addition which doubles the area of its present plant. The new space is being used for manufacturing high-speed coil winders and for an enlarged engineering and design department . . . The new \$400,000 plant of **HALLICRAFTERS CANADA LIMITED** has been dedicated with elaborate ceremonies attended by U.S. and Canadian television industrialists. The plant is located at Don Mills, a suburb of Toronto.

ROBERT J. MUELLER has been promoted to the post of sales manager of *Walsco Electronics Corporation* of Los Angeles.



Mr. Mueller has worked in practically all departments of the firm during the past four years. His previous position was assistant sales manager.

His initial efforts as head of the sales department will be the promotion of the company's new u.h.f. converter and three new antenna models.

AUDIO WORKSHOP, INC. has been formed in Chicago to handle the sales, installation, and servicing of high-fidelity music systems. The consulting firm has offices at 725 S. LaSalle Street. Principals in the new organization include Sam Denvov, president; Charles J. Taylor, Jr.; and Peter M. Keim, secretary-treasurer . . . **DAVELLE LABORATORIES, INC.** has been established at Springfield Gardens 13, N. Y. to provide a new source for all types of printed circuits. The circuits will be

(Continued on page 115)

RADIO & TELEVISION NEWS

CREI prepares you quickly for success in

The future is in your hands!

The signs are plain as to the future of the trained men in the electronics industry. It is a tremendous industry, and—at the *present time* there are more jobs than there are trained men to fill them. But—when there's a choice between a trained and untrained applicant, the trained man will get the job. Your biggest problem is to decide on—and begin the best possible training program.

CREI Home Study . . . The Quick Way to Get There.



Since 1927, CREI has given thousands of ambitious young men the technical knowledge that leads to more money and security. The time-tested CREI procedure can help *you*, too—if you really want to be helped. CREI lessons are prepared by experts in easy-to-understand form. There is a course of instruction geared to the field in which you want to specialize. You study at *your* convenience, at *your* rate of speed. Your CREI instructors guide you carefully through the material, and grade your written work personally (not by machine).

Industry Recognizes CREI Training.

CREI courses are prepared, and taught with an eye to the needs and demands of industry, so your CREI diploma can open many doors for you. Countless CREI graduates now enjoy important,

good-paying positions with America's most important companies. Many famous organizations have arranged CREI group training for their radio-electronics-television personnel. To name a few: All America Cables and Radio, Inc.; Canadian Aviation Electronics, Ltd.; Canadian Broadcasting Corporation; Columbia Broadcasting System; Canadian Marconi Company; Hoffman Radio Corporation; Machlett Laboratories; Glenn L. Martin Company; Magnavox Company; Pan American Airways, Atlantic Division; Radio Corporation of America, RCA Victor Division; Technical Appliance Corporation; Trans-Canada Air Lines; United Air Lines. Their choice for training of their own personnel is a good cue for *your* choice of a school.



*Benefits Felt
Right Away.*

Almost immediately, you feel the benefits of CREI training. Your employer, when informed of your step toward advancement (only at your request), is certain to take new interest in you and in your future. What you learn in CREI Home Study can start helping you do a better job immediately.

- BROADCASTING
- TELEVISION
- MANUFACTURING
- COMMUNICATIONS
- SERVICING
- AERONAUTICAL ELECTRONICS



CREI also offers Resident Instruction

at the same high technical level—day or night, in Washington, D. C. New classes start once a month. If this instruction meets your requirements, check the coupon for Residence School catalog.

INFORMATION FOR VETERANS

If you were discharged after June 27, 1950—let the new G. I. Bill of Rights help you obtain resident instruction. Check the coupon for full information.

Get this fact-packed booklet today. It's free.

Called "Your Future in the New World of Electronics," this free illustrated booklet gives you the latest picture of the growth and future of the gigantic electronics world. It includes a complete outline of the courses CREI offers (except Television and FM Servicing) together with all the facts you need to judge and compare. Take 2 minutes to send for this booklet right now. We'll promptly send your copy. The rest—your future—is up to you.



CAPITOL RADIO ENGINEERING INSTITUTE

An Accredited Technical Institute • Founded in 1927

3224 16th Street, N.W. Washington 10, D. C.

MAIL COUPON TODAY

CAPITOL RADIO ENGINEERING INSTITUTE
Dept. 111-A, 3224 16th St., N.W., Washington 10, D. C.

Send booklet "Your Future in the New World of Electronics" and course outline.

CHECK FIELD OF GREATEST INTEREST

<input type="checkbox"/> TV, FM & Advanced AM Servicing <input type="checkbox"/> Practical Radio Engineering <input type="checkbox"/> Broadcast Radio Engineering (AM, FM, TV) <input type="checkbox"/> Practical Television Engineering	<input type="checkbox"/> Aeronautical Radio Engineering
---	---

Name.....

Street.....

City..... Zone..... State.....

Check— Residence School Veteran

DISCOVER WHAT **GOLD**

AND 2 INCHES OF AIR

DO FOR

2

NEW

WALSCO ANTENNAS

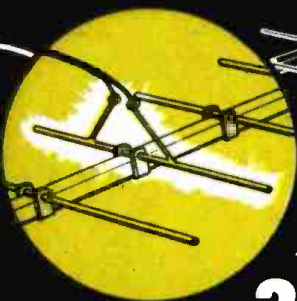

AMAZING
3 YEAR
GUARANTEE

● **NEW WALSCO GOLD DIPOLE YAGI (UHF)**

No less than 24 *kt. gold* plating on the receiving dipole of this great, new, 10 element Yagi. Why *gold*? Because *gold* resists corrosion better than any other metal... and *gold* is an excellent conductor. Like the most powerful *radar* antennas, the *Walsco Gold Dipole Yagi* guarantees *permanent* high gain in any location, under all weather conditions. It's custom-made for each location. The *only* Yagi that carries a 3 *year* unconditional guarantee! And it costs no more than conventional Yagis.

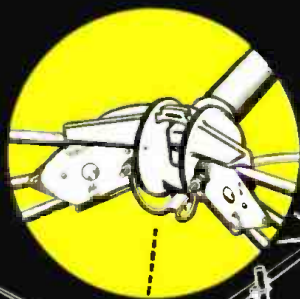

● **NEW WALSCO IMPERIAL CONICAL (VHF)**

Here's the first radical improvement in Conicals. A new insulator which utilizes "barrier discs" and 2 *inches of air space* between the terminals prevents "shorts." Soot deposits, dirt, moisture, salt, etc., *cannot* affect the insulator. This great, new *Conical* will therefore maintain high gain performance under any and all weather conditions. Front-end hardware is *stainless steel* to prevent corrosion losses permanently. Takes only 2 minutes to assemble because there's no loose hardware. Nothing compares to the *Walsco Conical* at any price... and it's backed by the *only* 3 *year* unconditional guarantee!

Write for complete information

WALSCO ELECTRONICS CORPORATION

Let's face it...

... the best tube you can buy
is your best buy

When it comes to anything so important in radio and television servicing as a receiving tube, *performance* means much more than *price*.

After all, when you purchase a receiving tube, you are not buying just glass and metal. Your reputation and your profit depend on the *performance* that tube will provide!

If you try to cut corners by buying "seconds" . . . or by using "just any tube brand," you may be in for trouble. Unnecessary callbacks alone can eat up all your profit. That's why we think you'll be interested in these two facts about RCA Receiving Tubes . . .

First Fact: There is no such thing as a "second" RCA Receiving Tube that can find its way to market. If an RCA Tube fails to pass its final test, it is not only rejected . . . *it is broken up, dumped into a "meat chopper" and ground up into so much hash.*

Second Fact: The quality of RCA Receiving Tubes is continually being "upgraded." For instance, when television came, you asked for an improved 6SN7-GT. As a result, RCA's 6SN7-GT is a far better tube than the 6SN7-GT of yesterday. You see, we guard our reputation as zealously as you guard yours.

So let's face it . . . you just can't afford to buy anything less than the best in receiving tubes—and that's RCA.



To be sure you're getting unused, factory-fresh RCA Tubes, buy them only in the familiar red, white and black RCA Tube cartons through your authorized RCA Tube Distributor.



RADIO CORPORATION of AMERICA
ELECTRON TUBES

HARRISON, N. J.

THIS ANTENNA OUT-PERFORMS:

this ... this ... this ... or this

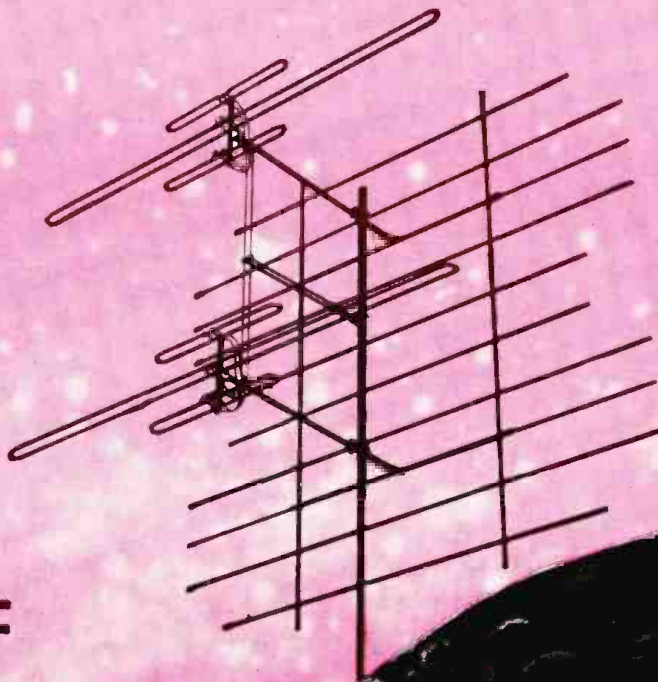
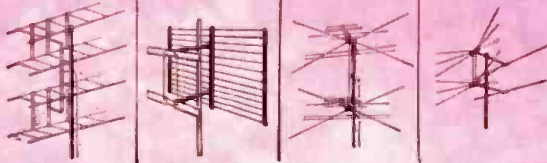

the AMAZING VHF CHAMPION*

a NEW KIND of Antenna
that out-performs every all-channel
VHF antenna ever made — —
and many Yagis, too!

America's servicemen have spoken! In only 2 months, they've made the CHAMPION the nation's top-selling VHF antenna! It's the highest gain all-channel VHF antenna ever developed, and its performance has now been proven by over 30,000 outstanding installations.

Only the CHAMPION has the unique new "Tri-Pole", a triple-powered dipole system in which the Low Band dipole also functions as three dipoles tied together, in phase, on the High Band.

Folded dipoles throughout give close to 300 ohms impedance across entire band. Lightweight, all-aluminum construction. Available in one, two, or four-bays.

CHANNEL MASTER CONQUERS SPACE!

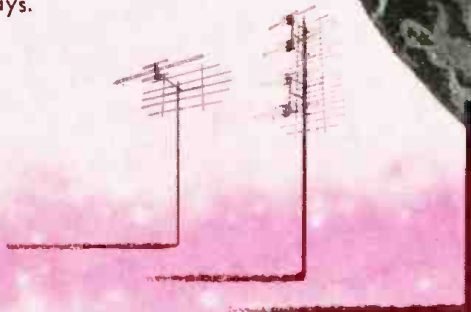

The stacked CHAMPION provides:

- 11-13 DB High Band gain
- 6½-7½ DB Low Band gain

Assembles faster than a five-element Yagi.
Screen "Pops-Up" instantly. "Tri-Pole"
assembly just snaps into place.

horizontal
polar pattern
(relative
voltage)

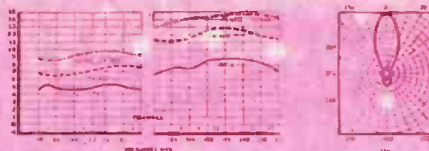

CHANNEL MASTER CORP.
ELLENVILLE, N. Y.



model no.		list price
325	single bay	\$20.00
325-2	two bay	42.00
325-4	four bay	88.00
Separate Stacking Harnesses		
325-3	2 bay harnesses	\$2.00
325-5	4 bay harnesses	4.00

*Pat. Pend.

3 great, new UHF antennas

by **CHANNEL MASTER**

STACKED TWIN CORNER REFLECTOR model no. 406-2

The most powerful UHF fringe area installation you can make today!

- Broad Band coverage — yet out-performs most stacked Yagis.
- Covers every UHF channel, not just segments of the band.
- New impedance-matching, two-stage stacking system.

Another original Channel Master development!

Model No.	Description	List Price
406	Twin Corner Reflector	\$18.06
406-2	2-Bay Twin Corner Reflector. Stacking harness furnished free.	36.10
406-3	Stacking harness only, furnished separately.	2.08

up to
17½ DB

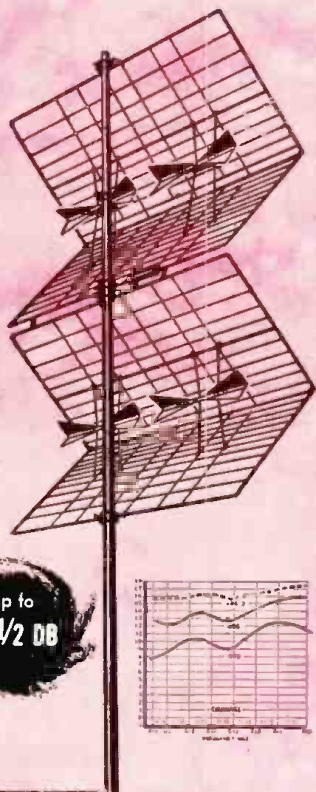
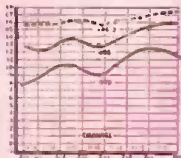

*powerful
new
antennas
span
vast
distances*

the first UHF CORNER REFLECTOR with optional "2-way" mounting!

model no. 409

Only CHANNEL MASTER'S CORNER REFLECTOR can be adapted to any kind of UHF installation — with or without VHF — at no extra cost. Every antenna contains all necessary hardware and braces for BOTH popular types of mounting. Sharp directivity and unusually high gain across entire UHF band.



mounts

this way . . . or this way

only
\$903
list

Installs instantly! Original Channel Master assembly feature: Screen swings open like a book — dipole assembly snaps into place.

"SWEET 16" The World's First 16-Element UHF Yagi!

- Custom-designed for your particular area.
- Super-power! Sensational fringe area reception.
- Delt-Weld design. Elements WELDED to crossarm. Delta-matched dipole gives uniform impedance.
- Wide band coverage, up to 21 channels.
- Average gain: 13 DB single
16 DB stacked

model no. 420



Send for complete technical literature.

CHANNEL MASTER CORP.
ESTABLISHED, 1937





HERE ARE JUST A FEW OF THE **BIG VALUES** IN THE 156 PAGE 1954 **B-A CATALOG** WRITE US, IF YOU HAVE NOT RECEIVED IT

BURSTEIN-APPLEBEE CO. Dept. M, 1012-14 McGee St., Kansas City 6, Mo.

- Send Free B-A Catalog No. 541
- My order attached for items in this ad.

\$..... enclosed.
 Name.....
 Address.....
 City..... State.....

FREE
 1954
B-A CATALOG

FORMER SELL-OUT AGAIN AVAILABLE NOW ONLY **\$13.69**

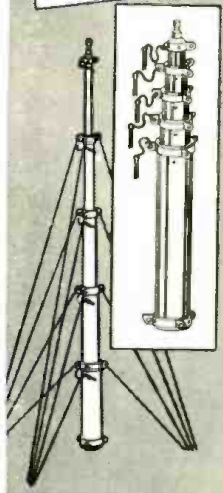

41-FT. TELESCOPING STEEL MAST FOR TELEVISION, ETC.

Thousands were previously grabbed up as an outstanding buy at \$24.88. Now, another huge special purchase from Gov't. surplus makes possible this Terrific Bargain. (Original Gov't. cost said to be \$60.00 each. Built to rigid Army Specs. (AN-S-2) for portable field lighting... ideally suited for a truly superior TV mast as well as for amateur beams, lighting, flagpoles, etc.

Compare these specifications with ordinary TV Masts... 5 sections extend to 41 ft., telescope to 9 1/2 ft. Super-strong chrome alloy seamless steel tubing, baked brown weather-proof enamel inside and out. Two machined close-fitting bushings and 3-hole guy ring at each joint. Sections extend easily, are held in position by heavy cross pins... May even be raised horizontally fully extended, with no buckling! Can be dis-jointed for shortening or dividing. Top section diameter 3/4" yet stronger than usual TV masts and of ample size to accommodate antenna mast clamp hardware. Mid-sections 1 3/8", 1 3/4" and 2 1/8". Base section 2 1/2" diameter.

Makes possible at low cost ground mounted antenna systems commonly preferred to roof-top installations because of less hazard for the installer and the home—plus better choice of antenna location.

Order Now While Available at this Low Price! Every Mast Brand New.
 No. 6A85. Shpg. wt. 40 lbs. **\$13.69**
 SPECIAL EACH
 4 Masts in Original Wood Crate Shpg. wt. 200 lbs. Lots of 4 for... **\$49.97**

BATTERY-OPERATED TELEPHONE HANDSETS



\$4.59
 PAIR

Provides, at an unbelievably low cost, a dependable two-way phone system, powered by self-contained flashlight batteries (935 Eveready or equivalent) and operated over two-conductor wire for distances up to 1 mile with exceptionally fine speech reception, equal to that of any ordinary telephone.

Ideal for TV installers in making proper alignment of roof attic antennas. "Just-it" for construction gangs, temporary communication systems in factories, on the farm, in homes or for emergency uses. So simple in operation even a child can use it for house-to-house, house-to-garage, and other play uses. Push button switch automatically connects battery.

Molded of break-resistant telephone-black polystyrene. Complete, ready to use with clips for easy connection to any two-conductor wire.

No. 20A946. (less batteries) **\$4.59** 6 Pair **\$3.94**
 Per Pair
 Batteries for above (requires one per phone) No. 21A2. Each...10c
 Two Conductor Telephone Wire: No. 2A171. Per 100 Feet...95c



COMPLETE AM-FM HI-FI RADIO CHASSIS
NATIONALLY-KNOWN MAKE

REGULAR \$138.50
 NET VALUE
 FOR ONLY **\$99.50**

DeLuxe Tuner Chassis and Amplifier power supply in separate units with 20 Tubes including tuning eye and rectifiers assures maximum efficiency of each unit and provides more latitude in installations.

The Tuner, an AM-FM Superhet Features: Built-in Pre-amp for use of GE or other Variable Reluctance Cartridges, as well as Crystal type, 6-gong Tuning Condenser, AVC, Separate Full Range Bass and Treble Controls, Fly Wheel Tuning Drive, Tuning Eye.

Separate Tuned RF stages are employed on both the AM and FM bands to provide extreme sensitivity and minimize spurious responses. The FM circuit also includes two stages of high gain IF amplification and a ratio detector circuit of advanced design—all stabilized against drift.

Tunes AM: 535 to 1720 KC—FM: 88 to 108 MC. Sturdily built with pleasing panel, indirectly illuminated "Slide" Ruler Dial. Controls at front include 3-position selector switch for Phono, AM, FM radio. AC phono outlet in rear. Supplied with AM loop antenna and FM flexible dipole with provision for external antennas.

Tube complement: 2-6BA6, 2-6BE6, 6C4, 6SG7, 6SH7, 6J5, 6SQ7, 6AL5 and 6U5. Supplied complete with tubes, antennas and hardware.

The Power Supply and Audio Amplifier, designed specifically for above, features Parallel Push-Pull Beam Power Output... 18 watts undistorted, 25 watts max. power. Extended Range Hi-Fi Response, Inverse Feedback, Output Impedance 4, 8, 15, 250 or 500 ohms. Tube Complement: 2-6J5, 4-6V6, 2-5Y3. Supplied complete with tubes and connecting cable.

Dimensions—Tuner: 13 1/2" W. x 8 1/2" H. x 9" D. Wt. 10 lbs. Amplifier: 13 1/2" W. x 7 1/2" H. x 7" D. Wt. 18 lbs. Operate from 105-125 volts AC; 50/60 cycles. Shpg. wt. of both 31 lbs.

No. 31B217-2. Tuner and Amplifier Complete Ready to Operate. Both for Only **\$99.50**

COMBINATION DEAL—Above Tuner and Amplifier with Garrard Changer and GE Variable Reluctance Turnabout Cortridge. Deal No. 31A282. Shpg. wt. 53 lbs. Special. **\$139.50**

AMAZING VALUE! TV DEFLECTION UNIT

IT'S A "NATURAL" FOR EXPERIMENTERS, STUDENTS, SCHOOL INSTRUCTION, TV STATION MONITORS, ETC.

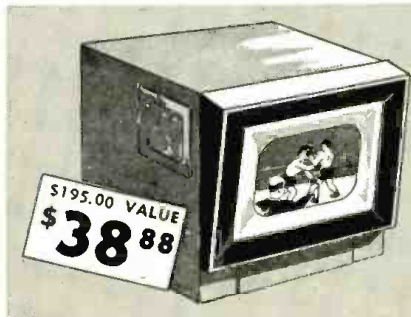

Pictured here is the TV Deflection Unit which with a Tuner Unit comprised the "Trans-vue Entertainer." Briefly, a 16 inch picture was obtained from this Deflection Unit, the tuning being accomplished from a Tuner Unit at any location away from one to 4 of these Deflection Units.

Such installations were popular in the Home, Business or Institutions, but too costly to sustain the high selling and mfg. costs. The inventory was therefore liquidated... But remaining were a huge quantity of the Deflection Units alone. At this point B-A came in and made a deal that brings you this original \$195.00 Value Deflection Unit at a Ridiculous Low Price!

This Deflection Unit, quality built throughout by Belmont, a division of Raytheon, consists of all video, sync., horizontal and vertical sweep and high voltage supply circuits as well as the audio amplifier and 8" PM Speaker. All power supplies and all tubes (except 16AP4 picture tube) are in the chassis... completely factory wired and installed in sturdy good looking mahogany finished wood cabinet as illustrated above. Dimensions: 23 1/4" H. x 23 1/2" W. x 26 1/2" D. (top) —23 1/4" D. (bottom). The addition that it is needed to make this unit a conventional TV Set is the RF-IF Detector system. This front end portion may be easily obtained from any inter-carrier chassis from a discarded used TV set or it may be made up with a tuner and IF strip. (Schematic diagram of both this Deflection Unit and remote tuner originally used with same is included.)

This Unit, therefore provides a "Natural" for interesting experimentation to qualified TV Hobbyists, Students, for School instruction, TV Station Studio Monitors, etc., a Terrific Value also to disassemble for the tubes and components for servicing and other uses. To list all these items would require a full page this size.

Consists of 22 Tubes: 2-6AL5, 1-6AU6, 1-6K6, 2-5U4, 1-6W4GT, 5-SOC5, 4-6SN7, 2-1B3, 3-50L6, 1-Ballast, 45 Capacitors, 88 Resistors, Coils, Transformers, Chokes, 8" PM Speaker, the Chassis, Sockets, and usual other miscellaneous parts and fittings, the Cabinet Mask, etc., plus long length AC line cord and Video Cable and Plugs. Every One Brand New Factory Assembled and Complete (less 16AP4 Picture Tube.)

No. 40A202. Shoe. wt. 117 lbs. SPECIAL NET EACH **\$38.88**

TERMS: F.O.B. Kansas City. Remit with order, include postage for parcel post shipments.



BURSTEIN-APPLEBEE CO.

1012-14 MCGEE ST. KANSAS CITY, MO.

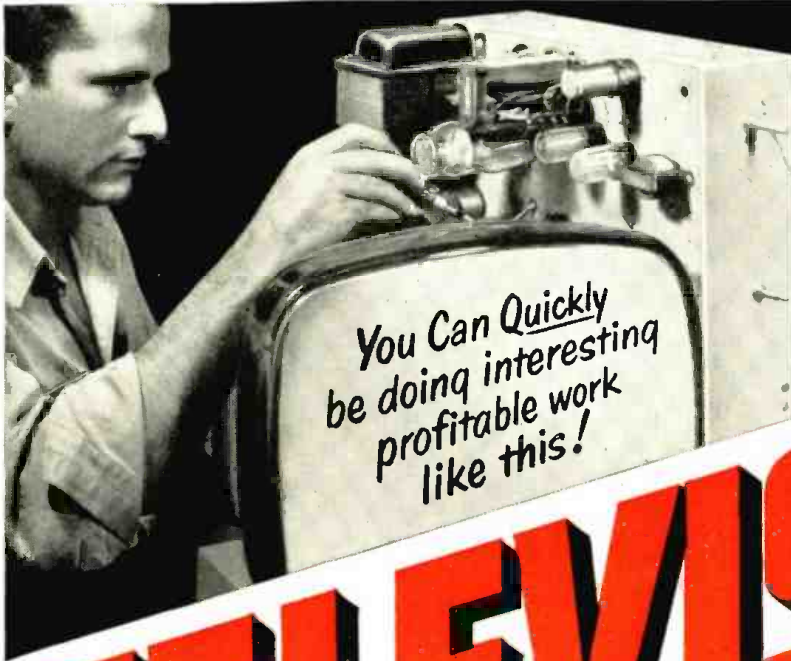

*Prepare now for
the great opportunity
field of...*

*You Can Quickly
be doing interesting
profitable work
like this!*

TELEVISION

RADIO-ELECTRONICS

*In spare time
at home!*

A fascinating field! A great future! A good job or independence in a business of your own! TV is growing by leaps and bounds—1227 new communities, 1845 new stations have been given the "go-ahead". Trained men are worth their weight in gold!

MODERN TRAINING BY COYNE RIGHT IN YOUR OWN HOME

Here is modern, up-to-the-minute Home Training in Television and Radio designed to meet the standards that have made the Coyne School famous for many years. You get personal supervision by members of Coyne instruction staff—men who know TELEVISION AND RADIO AND KNOW HOW

B. W. COOKE, President

COYNE SCHOOL

A TECHNICAL TRADE INSTITUTE
CHARTERED NOT FOR PROFIT
Established 1899

500 S. Paulina Dept. 14-HR5, Chicago 12,

TELEVISION ★ RADIO ★ ELECTRICITY ★ REFRIGERATION ★ ELECTRONICS

TO TEACH IT—men who have helped train thousands of men and young men, Service men and Veterans.

LEARN TO EARN IN SPARE TIME

COYNE offers a most practical, down-to-earth Home Television Training. Simple, easy to follow step-by-step instructions, fully illustrated. So practical, you can quickly be earning money in Television and Radio and keep your present job while training.

Let us show you that this is not only the newest, most up-to-the-minute Training in Television-Radio-Electronics—but also it costs you much less than you'd expect to pay. Send coupon today for details including Easy Payment Plan.

B. W. COOKE, President
COYNE SCHOOL
500 S. Paulina St., Chicago 12
Dept. 14-HR5

Send details of your offer on training checked below. This does not obligate me and no salesman will call. I am interested in:

- Television-Radio Home Training
- Electricity in Coyne Shops
- Television-Radio in Coyne Shops

Name

Address

City State

YOU CAN ALSO TRAIN FOR

TELEVISION-RADIO OF ELECTRICITY
IN THE GREAT SHOPS
OF COYNE AT CHICAGO



Coyne, of course, also offers practical resident training in the Coyne Training Shops here in Chicago in the fields of TELEVISION-RADIO and ELECTRICITY. If you prefer to get information about our resident courses in either or both of these fields, then check on the coupon accordingly and mail it to us. Our fully illustrated 48 page Guide To Careers in Television-Radio and Electricity and complete details about our resident training will be sent you by return mail. No cost or obligation to you, of course, and no salesman will call on you.

MAIL COUPON FOR INFORMATION

Fill in and mail coupon TODAY. Paste it on a postcard if you wish. Complete details will come by return mail. No cost—no obligation and no salesman will call.

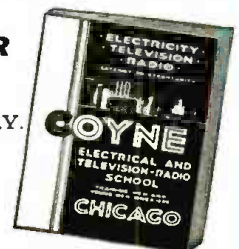

NOW... 2 SENSATIONAL EICO SCOPE VALUES!

NEW AMAZING FEATURE PACKED
7" PUSH-PULL OSCILLOSCOPE

Only **EICO** Has All These Features

- VERTICAL FREQ. RESPONSE: flat ± 2 db 10 cps - 1 mc
- VERTICAL SENS.: .01 volts rms/inch
- HOR. FREQ. RESP.: flat ± 0 db 10 cps - 200 kc, -4 db at 500 kc
- HOR. SENS.: .3 volts rms/inch
- SWEEP RANGE: 15 cps-100 kc
- 3-STEP FREQ.-COMPENSATED ATTENUATOR eliminates freq. distortion, overloading.
- CATHODE FOLLOWER inputs to both amplifiers
- PUSH-PULL outputs in both amplifiers
- RETURN TRACE BLANKING
- INT. VOLTAGE CALIBRATOR
- V & H TRACE EXPANSION & CENTERING: 1.5X full screen without distortion.
- DIRECT CONNECTION to vert. CRT plates.
- PHASING CONTROL of internal 60 cps sine wave sweep.
- AT FRONT PANEL: Intensity mod. input; 60 cps, sawtooth outputs.



MODEL 470K
KIT \$79.95. WIRED \$129.50.

EICO EXCLUSIVE! 5" PUSH-PULL SCOPE, 425K, Amazing feature-packed economy-priced
Wired, \$79.95.

- PUSH-PULL V & H amplifiers. Sens. 0.5-1 rms v/in. Useful to 2.5 mc.
- SWEEP: 15 cps-76 kc. Z-axis intensity modulation. Dual trace positioning controls.



SCOPE VOLTAGE CALIBRATOR KIT
495K KIT \$12.95. WIRED \$17.95.

- Sq. wave output at power-line freq. with full-scale readings of .1, 1, 10 or 100 V. peak-to-peak.
- Accuracy $\pm 5\%$ of full-scale on each range.

6V & 12V BATTERY ELIMINATOR KIT
1050K KIT \$29.95. WIRED \$38.95.

- DC output: 0-8 V or 0-16 V.
- Continuous current rating: 10 A at 6 V, 6 A at 12 V.
- Intermittent current rating: 20 A at 6 V, 12 A at 12 V.
- Separate Voltmeter & Ammeter.



New! EICO SCOOPS!

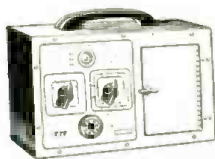

CATHODE RAY TUBE CHECKER
630K, WIRED \$24.95 KIT, \$17.95.

- Checks all types of TV picture and C.R. tubes in the set or carton. Bridge measurement of peak beam current (proportional to screen brightness).
- Detects shorted & open elements.

BAR GENERATOR
352K, WIRED \$19.95 KIT, \$14.95

- Enables rapid adjustment of TV picture V & H linearity without hard-to-find station-transmitted test pattern.
- Produces 16 V or 12 H bars. Operates on TV channels 3, 4, or 5.

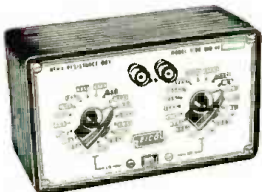
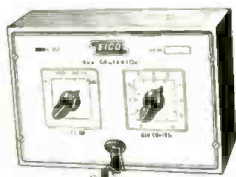

RTMA RESISTANCE
SUBSTITUTION BOX
1100K WIRED \$9.95 KIT, \$5.50.

- Enables rapid substitution of resistances from 15 ohms to 10 megs in decade multiples of 15, 22, 33, 47, 68, 100 ohms.
- Uses 36 standard 1 watt, $\pm 10\%$ RTMA resistors.

221K VTVM KIT \$25.95. WIRED \$49.95.

- AC & DC volts: 0-5, 10, 100, 500, 1000 V (30 KV with HVP-1 probe).
- 5 ohm ranges from 2 ohm to 1000 megs.
- DC input Z 26 meg.
- $4\frac{1}{2}$ " meter movement in can't-burn-out circuit.
- 1% mult. resistors.



360K SWEEP GEN. KIT \$34.95. WIRED \$49.95.

- Continuous coverage of all TV & FM freqs. from 500 kc to 228 mc.
- Sweep width variable 0-30 mc.
- Crystal marker oscillator, variable amplitude.

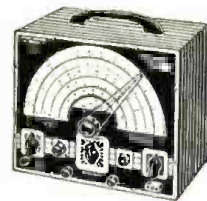

HIGH VOLTAGE PROBE \$6.95

- Extends range of VTVMs & voltmeters to 30 KV.



PIX TUBE ADAPTER
for Tube Testers \$4.50.
Checks TV picture tubes while in set.

625K TUBE TESTER KIT \$34.95. WIRED \$49.95.



- Illum. gear-driven "Speed Rollchart."
- New lever-action switches for individual testing of every element.
- Tests all conventional & TV tubes.

COUNTER CABINET for above: add \$10.00 to Kit or Wired Prices.

214K VTVM KIT \$34.95. WIRED \$54.95.

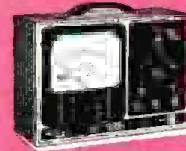

- Large $7\frac{1}{2}$ " meter, can't-burn-out circuit.
- AC/DC volts: 0-5, 10, 100, 500, 1000 (30 KV with HV Probe).
- 5 ohm ranges from 2 ohm to 1000 megs.
- DC input Z 26 meg.
- 1% mult. resistors.

950A-K R-C BRIDGE & R-C-L COMP. KIT \$19.95.
WIRED \$29.95.

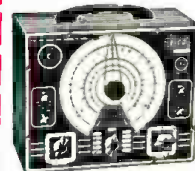

- Measures & tests all resistors; 5 ohm to 500 megohms.
- Every type condenser, 10 mmf to 5000 mfd.
- 0-500 DC voltage source for capacitor leakage testing.

NOW! ONLY EICO KITS & WIRED INSTRUMENTS Gives You LIFETIME SERVICE & CALIBRATION GUARANTEE*

*at less than our cost of handling (See EICO Guarantee Card enclosed with each Kit & Instrument).

1717K RES. DECADE BOX KIT \$19.95. WIRED \$24.95.

- Resistance values from 0 to 99,999 ohms with 0.5% precision.
- All resistors have 0.5% accuracy



DECADE CONDENSER BOX KIT
1180K KIT \$14.95. WIRED \$19.95.

- All capacitors precision silver mica, accuracy $\pm 1\%$.
- Range from 100 mmf - 0.111 mfd in steps of 100 mmf.
- Smooth-action positive detent ceramic switches.



Prices 5% higher on West Coast. Specifications and prices subject to change without notice.

315K DELUXE SIG. GEN. KIT \$39.95. WIRED \$59.95.

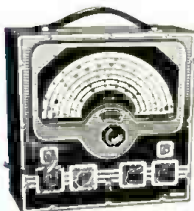

- Covers range of 75 kc to 150 mc.
- 7 calibrated scales: accuracy better than 1%.
- Bandsread vernier tuning.
- 4-step RF shielded output multiplier: constant output Z.

565K MULTIMETER KIT \$24.95 WIRED \$29.95.



- 555K MULTIMETER KIT \$29.95
WIRED \$34.95.
(1% precision resistors)
- 20,000 Ω/V ; 31 ranges.
 - DC/AC/Output volts: 0-2.5, 10, 50, 250, 1000, 5000.
 - DC Current: 0-100 ua; 10, 100, 500 ma; 10 A.
 - Ohms: 0-2K, 200K, 20 meg.

377K SINE & SQUARE WAVE AUDIO
GEN. KIT \$31.95. WIRED \$49.95.



- Complete sine wave coverage, 20-200,000 cps in 4 direct-reading ranges.
- Complete square wave coverage, 60-50,000 cps.
- Cathode follower output circuit.

145K SIG. TRACER KIT \$19.95.
WIRED \$28.95.



- Audibly signal traces all IF, RF, Video & Audio circuits from ANT to SPKR or CRT in all TV, FM, AM, etc. without switching.
- Germanium crystal diode Probe responsive to over 200 mc.
- Integral test speaker.

536K MULTIMETER KIT \$12.90. WIRED \$14.90.
526K MULTIMETER KIT \$13.90. WIRED \$16.90.



- 1000 Ω/V ; 31 ranges
- DC/AC volts: Zero to 1, 5, 10, 50, 100, 500, 5000.
- DC/AC Current: 0-1, 10 ma; 0.1, 1 A.
- Ohms: 0-500, 100 K, 1 meg.

320K SIG. GEN. KIT \$19.95. WIRED \$29.95.
322K SIG. GEN. KIT \$23.95. WIRED \$34.95.



- Fundamentals 150 kc to 34 mc, harmonics to 102 mc.
- 5-step band switching.
- Colpitts audio oscillator generates 400 cps pure sine wave voltage.
- Permits pure RF, modulated RF, or pure AF.

Write NOW for FREE latest Catalog R-1

Ask your jobber for FREE EICO business building decals.

Separate Assembly & Operating Manuals supplied with each EICO KIT!

You build EICO Kits in one evening, but... they last a lifetime!

SAVE OVER 50%! See the famous EICO line TODAY, at your local jobber.

ELECTRONIC INSTRUMENT CO., Inc. 84 Withers Street, Brooklyn 11, N. Y.

www.americaninstrument.com



SHORTLY after vacuum-tube radios were first put into production, experimenters began to look for other uses for vacuum-tube circuits. One of the early developments was a unique musical instrument, played by the free movement of the performer's hands in the space surrounding the instrument. This device, named the "Theremin" after its inventor, Leon Theramine, attracted widespread attention. Today, Theremin music is still quite popular, despite the fact that no new instruments have been built commercially for about twenty-five years.

Musically, the Theremin is capable of a great deal of individualism and expression. The pitch is controlled by varying the distance between one hand and a control rod. Volume is similarly controlled with the other hand. There are no keys or "notes" on the Theremin. The position of the performer's hands is the only factor that determines the pitch and volume of the sound.

As an electronic instrument using up-to-date circuits and tubes, a Theremin may be constructed at a very nominal cost, and give completely satisfactory performance. In the instrument about to be described, the tone is produced by two radio-frequency oscillators beating at an audible frequency. The addition of hand capacity to the pitch control antenna lowers the frequency of one of the r.f. oscillators, and the pitch of the beat frequency is correspondingly changed. The outputs of the two r.f. oscillators (V_1 and V_2 in Fig. 3) are mixed, and the r.f. components of the resultant signal removed by means of a diode detector.

In the volume control circuit, the addition of hand capacity to the volume control antenna causes a change in the frequency of a third oscillator, V_3 . The output of this oscillator is fed through a series of tuned circuits, T_1 and T_2 , and then rectified. The rectified voltage is used as grid bias to control the gain of a variable mu amplifier tube. A change in the oscillator frequency will vary the grid bias and, therefore, the output of the amplifier. The output of this amplifier is fed directly into the power amplifier and from there into a loudspeaker.

The variable pitch oscillator uses the triode section of V_1 and its frequency is determined by two tuned circuits, L_1-C_1 , and L_2-C_2 . L_1 is a variable coil of high inductance, and has only its distributed capacity and a small variable condenser C_1 across it. Therefore, the resonant frequency of this tuned circuit will be appreciably lowered by a slight addition of hand capacity. On the other hand, L_2 has much less inductance and is tuned to resonance by a large fixed condenser C_2 . The two coils are coupled so that the tube oscillates at the average of their resonant frequencies. This pitch control oscillator is extremely sensitive to changes in hand capacity, but because of the low impedance of L_2-C_2 , changes in input capacitance of the

THE THEREMIN

By **ROBERT MOOG, K2AMH**

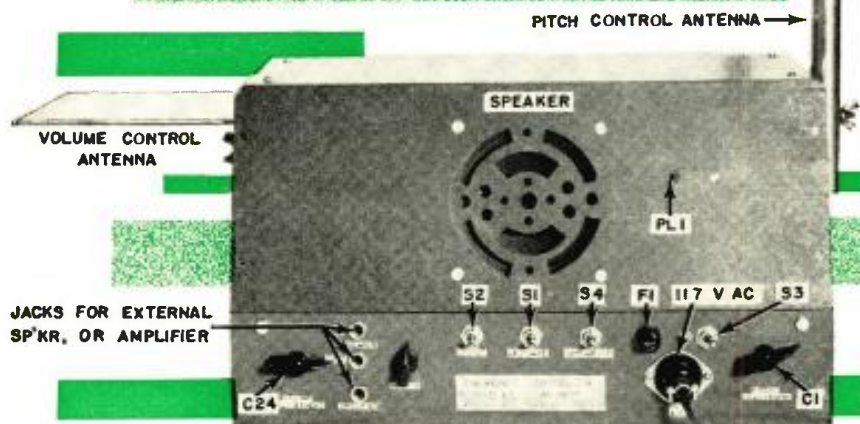

Fig. 1. Over-all view of the home-built Theremin. The cabinet is made of 1/2-inch plywood. The speaker panel is constructed of 1/4-inch Masonite. The antennas are mounted with through bolts and wing nuts.

By popular request—another Theremin article. This new design incorporates many refinements that provide greater operational stability—it is easy to build.

tube have no effect on it. Naturally, this stability is an extremely desirable feature in an electronic musical instrument.

The pentode part of V_1 acts as a buffer amplifier to further isolate the oscillator from extraneous disturbances. The output frequency is about two hundred kilocycles.

Except for the absence of an antenna coil, the operation of the fixed oscillator V_2 is identical with that of the variable oscillator. The outputs of the two oscillators are fed through isolating condensers into three r.f. transformers, which pass or reject harmonics produced by the oscillators. These high frequency harmonics produce corresponding overtones in the beat note and, by controlling these harmonics, distinctive qualities of tone may be produced by the instrument.

The volume control oscillator is identical to the pitch control oscillator, except for the tuned circuit values. The output is passed through two conventional i.f. transformers, T_1 and T_2 , and then rectified by the crystal diode, *Rect.1*. When the transformers are tuned to the same frequency as the oscillator, a maximum voltage difference of about eighty volts exists

across R_{12} . The oscillator frequency is then raised to a point where the voltage across R_{12} is about one half maximum, or forty volts. This provides operation on that portion of the sensitivity curve that results in the greatest change in voltage across R_{12} for a given slight variation in the oscillator frequency. To take advantage of this maximum sensitivity, the positive end of R_{12} is placed at a point on the voltage divider $R_{10}-R_{11}$, which is about forty volts above ground. Therefore, the negative end of R_{12} is at zero volts in relation to ground. With a slight addition of hand capacity to the volume control antenna, the junction of R_{10} and R_{12} will become negative in relation to ground. This negative voltage is used as grid bias to control the gain of the pentode section of V_3 . The amplifier will be completely cut off when the grid bias exceeds minus ten volts. R_{10} and C_{11} make up a time constant which eliminates clicks and pops resulting from sudden hand movements. The diode connected across C_{11} prevents the grid bias from accidentally going positive. The sensitivity of this volume control is such that the amplifier is completely cut off when the hand is a few inches from the antenna, and full

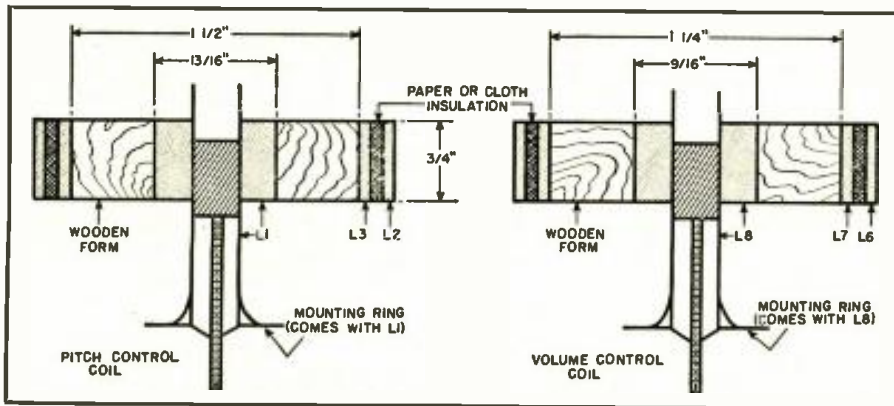

Fig. 2. Cross-sectional details of control coils. Dimensions should be exact.

volume is obtained with the hand about eighteen inches from the antenna. R_9 is used to set maximum volume.

The power supply uses a gas-type voltage regulator to supply the oscillators and the control amplifier, thereby adding to the over-all stability of the instrument.

As a musical instrument, the Theremin should be as compact and port-

able as possible. However, a distance of at least eighteen inches should separate the two antennas. The unit pictured is built on a 17 x 7 x 3 inch chassis and the antennas are mounted on the wooden housing, one on each end (see Fig. 1). The pitch control antenna is made of a sixteen-inch length of one-inch brass pipe, and the volume control antenna is made of a

5 x 7 inch sheet of sheet brass. C_1 and C_2 are used to "tune up" the instrument and should be placed on a convenient part of the panel. The unit must be adequately ventilated to prevent an extreme temperature rise that might otherwise result in frequency drift. It is recommended that R_{21} and R_{22} be mounted above the chassis, to prevent heating of the oscillator components. T_2 , T_3 , T_4 , and T_5 are all conventional broadcast i.f. transformers and may be either of the shielded or unshielded type. If unshielded transformers are used, they should be mounted under the chassis and holes drilled for adjusting the trimmer condensers (see Figs. 4 and 5). Placement of parts is not critical, since the oscillators work at low frequencies, and all circuits are of fairly low impedance. The oscillator coils should be carefully constructed however, since these are the "heart" of the instrument. In constructing the pitch control coil assembly (L_1 , L_2 , L_3) a ring with an outside diameter of $1\frac{1}{2}$ inches and inside diameter of $1\frac{3}{16}$ inch is cut from $\frac{3}{4}$ inch wood. On

Fig. 3. Complete schematic diagram for the Theremin. All voltage readings shown were taken with 20,000 ohms-per-volt meter.

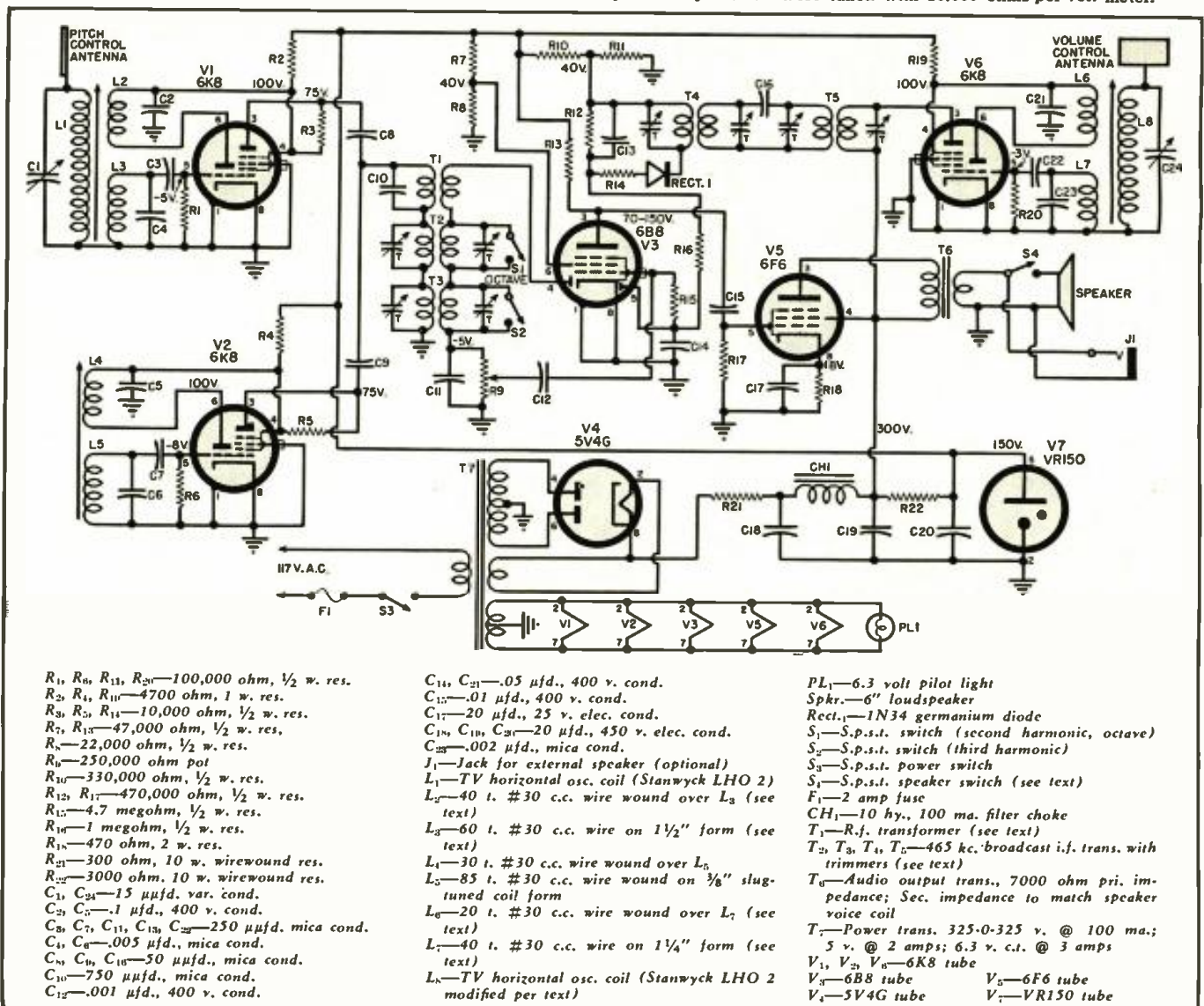

this form, L_2 is wound. A layer of insulation is placed over L_3 and L_2 is wound over the insulation. L_1 is then placed in the hole in the coil form (see Fig. 2). With L_1 in place, the entire assembly is coated with cement or coil dope. This assembly is seen in the upper right hand corner of Fig. 5.

The same procedure is followed for the volume control coil assembly (L_6, L_7, L_8), but the dimensions are different. L_6 is a coil of the same type as L_1 , except that enough wire is removed so that its outside diameter is just under $\frac{3}{16}$ inch and its resistance is 30 ohms. The wooden ring for this assembly has an outside diameter of $1\frac{1}{4}$ inches and an inside diameter of $\frac{3}{16}$ inch.

The fixed oscillator coil (L_1, L_5) is wound directly on a $\frac{3}{8}$ inch slug-tuned coil form. L_5 is wound and covered with insulation. L_1 is then wound over the insulation.

T_1 is wound on a $\frac{7}{8}$ inch wooden form. Both primary and secondary consist of 250 turns of No. 30 wire. The two windings are wound next to each other.

The two pitch oscillator coils should be placed at least six inches from each other and at right angles. This will prevent interaction between the magnetic fields surrounding the coils. To insure mechanical stability, all leads going to these coils should be solid rather than stranded wire. The antenna connections are brought out to connectors on the top of the chassis. The loudspeaker and pilot light are also connected in this fashion.

To adjust the Theremin, use a voltmeter with an internal resistance of at least 20,000 ohms-per-volt. After the wiring has been checked and the instrument plugged into the line, check that the voltages at the points indicated in Fig. 3 approximate the values given. Remove V_6 and touch the grid cap of V_3 . A loud hum indicates that the amplifier tubes are working. The unit is now ready to be aligned as follows:

1. Turn R_9 to zero volume. Place the voltmeter across R_1 and set C_1 to minimum capacity. Make sure that the pitch control antenna is connected properly. Start with the slug out of L_1 as far as possible and advance the slug until the voltmeter begins to dip. Continue advancing the slug until the voltmeter reaches its lowest point and begins to climb. At this point L_1-C_1 is at the same resonant frequency as L_3-C_1 , and the oscillator is most sensitive to hand capacitance.

2. Now set C_1 at half capacity and turn R_9 up half way. Adjust the slug in L_1-L_5 until a loud beat note is heard. Continue adjusting until the two oscillators are zero-beating.

3. Set C_1 for an audible note. Close S_2 and open S_1 . Tighten the trimmers on T_2 until a marked change in tone quality is heard. T_2 is now tuned to the second harmonic (octave) of the fundamental and may be shorted out by simply closing S_1 .

4. Close S_1 and open open S_2 . Loosen

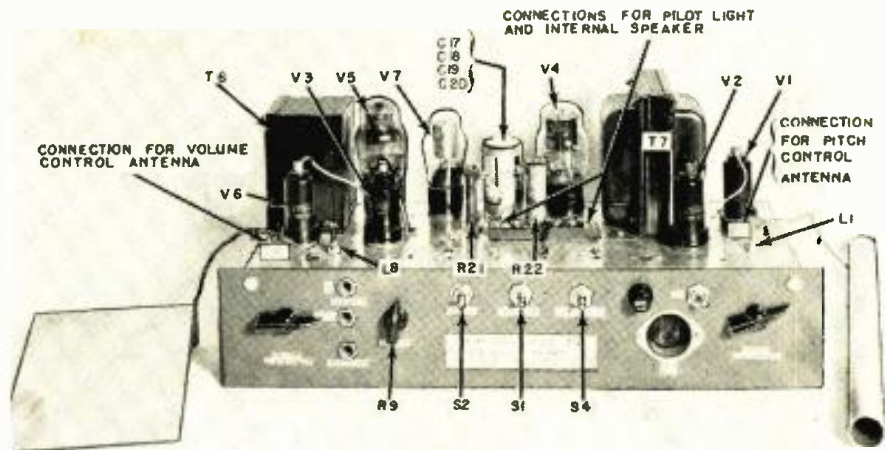

Fig. 4. Top chassis view of the Theremin. Antennas should be widely separated.

the trimmers on T_2 until a change in tone quality is heard. T_2 is now tuned to the third harmonic of the fundamental and may be shorted out by closing S_2 . With both S_1 and S_2 open, the resultant tone will contain both second and third harmonics.

5. Place V_6 in its socket and allow it to warm up. Set C_2 at minimum capacity and connect the volume control antenna. Place the voltmeter across R_{20} and adjust L_6 until the voltmeter shows the greatest dip. V_6 is now oscillating at about 500 kc.

6. Now set C_2 at maximum capacity and place the voltmeter across R_{12} . Adjust T_1 and T_3 trimmers for maximum voltage.

The unit is now ready to play. The chassis and antennas are mounted in the cabinet. C_1 is set for the lowest note that the performer wishes to play. Moving the hand toward the pitch control antenna should raise the pitch. C_2 is set so that movement toward the volume control antenna will reduce the intensity of the tone. In playing the instrument, the performer stands about two feet from the pitch antenna, and about $1\frac{1}{2}$ feet from the volume antenna. The top of the pitch antenna should be at shoulder level. The tone produced is not unlike that of a cello, and when S_1 or S_2 is open,

the tone resembles that of an oboe or English horn. A slight shaking of the hand produces a quivering effect (vibrato) that greatly enriches the tone. S_1 may be opened if the performer wishes to leave the power on while not actually playing the instrument.

No special techniques are used in playing the Theremin and anyone who can hum a tune is a candidate for the instrument. As with all musical instruments, practice is necessary to play the Theremin skillfully.

The Theremin is generally considered a musical novelty and there are very few accomplished masters of the instrument. The writer believes that the scarcity of instruments rather than any great difficulty in learning to play is responsible for this situation. The instrument herein described, in the writer's opinion, is the equal of any in existence, and incorporates added features that make it superior to any that he has seen or heard. Construction of the instrument should present no great trouble to anyone with some knowledge of electronic circuits and construction techniques. Beside the satisfaction of having built a musical instrument, the constructor will enjoy the distinction of being able to "pull music from the air."

-50-

Fig. 5. Underchassis view. Short, stiff leads are used in oscillator sections.

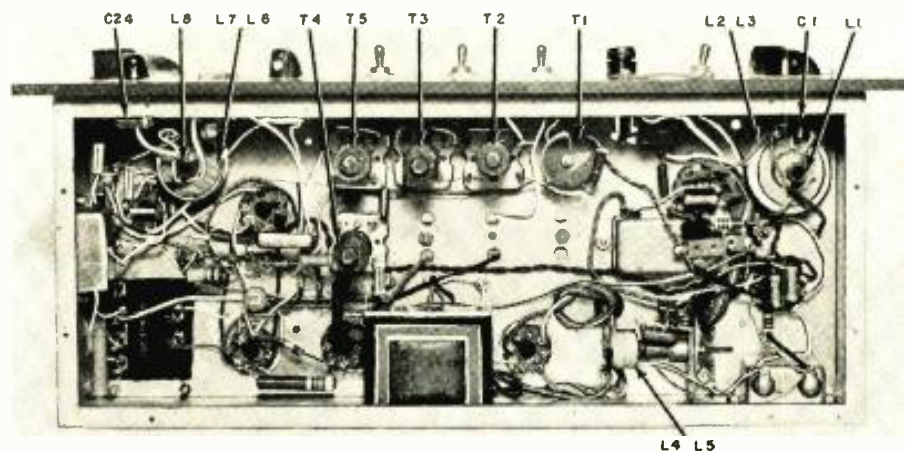

PAGES FROM A TAPE EDITOR'S NOTEBOOK

By

DONALD C. HOEFLER



Fig. 1. A starting cue may be marked either with a grease pencil or a slip of paper.

Part 3. How the sound of existing recordings can be improved in the transfer to tape. Dubbing methods are also discussed.

MAGNETIC tape recording has been a great boon to phonograph record manufacturers and collectors, for through this medium it is actually possible to restore the quality of old and damaged recordings. Most noises may be eliminated or materially reduced, and the sound quality may even be enhanced through re-recording on tape with modern techniques.

When transferring old disc recordings the first important tool of the editor is a complete set of pickup equalizers, which will provide playback curves which are the complements of the standard recording characteristics. When using these equalizers, one should ignore the name on the label of the record and forget any pre-supposition of the characteristic. There was great inconsistency in characteristics in early recordings despite published data to the contrary. It is best then to rely entirely upon the ear for this operation and, after trying all of the equalizer positions, use the one which *sounds* the best.

Surface noise rejection has been attempted in various ways, but the best method for this application remains the simple low-pass filter. A well-equipped studio has filters which cut off rather sharply above 10,000, 8000, 6500, 5000, and 4000 cycles. Each should be tried successively, beginning with the highest, until the one is found which will provide the greatest hiss reduction consistent with the least detriment to the music. It should be remembered that the maximum sensi-

tivity of the human ear is around 4000 cycles, and the two octaves of harmonics above that are not as essential to pleasant musical listening as high-fidelity theory would have us believe. There are in fact many LP recordings on the market which have been re-recorded from old discs with a 4000-cycle cut-off, which nevertheless have received wide public acceptance.

Many of the early records exhibit much low-frequency noise due to poor acoustics, machine rumble, or hum. Much of this can be eliminated by the insertion of a high-pass filter which cuts off around 100 cycles. This will not, of course, handle 120-cycle hum. If a high-pass filter is used which cuts off much above 100 cycles, it is usually desirable that some bass boost be added, otherwise, the low end will be too greatly attenuated by the filter and the resulting sound will be thin.

Bass boost, as well as a wide variety of other characteristics, is provided by a continuously variable equalizer. This device affords a choice of a number of rising and roll-off characteristics at either end of the audio spectrum, and the more elaborate ones even provide humps and depressions in the transmission characteristic within the spectrum. No rules can be given for the use of this valuable tool, as it is largely a subjective process. Here, as in all audio work, the trained ear is the final judge.

An extremely helpful device is a tunable narrow-band rejection filter,

which will literally "dip out" any single unwanted frequency. This instrument is unsurpassed for the complete elimination of 120-cycle hum (or any other ripple frequency, for that matter), as well as any unwanted oscillation which may have crept in anywhere throughout the audio spectrum. Such a facility is naturally complex and expensive, but well worth the cost if a great deal of this work is being done.

When transferring to tape from a lacquer disc, it is essential that the disc be absolutely clean. If the playback system provides interchangeable pickups, with a choice of tip radii of 2.5 or 3.0 mils, each should be tried, as one will usually provide a better signal-to-noise ratio than the other.

The disc is then played in rehearsal and experiments made with the various equalizing and filtering facilities until the best possible sound has been achieved. Level is set by playing the disc throughout and determining a fader setting at which the peak level on the disc will provide the maximum allowable level on the tape. Although many exceptions to this general rule will be encountered, it is preferable to avoid any volume compression; the dynamic range on the original record, unless completely out of proportion, should be faithfully retained in the transfer to tape.

The back-tracking method of cueing the beginning of a record, as widely practiced in radio stations, is damaging to the disc and therefore not recommended for this application. Instead the pickup is placed in the outermost lead-in groove and the turntable slowly rotated by hand. Then the number of turns is counted from the beginning of the lead-in to the beginning of sound. The disc is marked at

the point where sound begins, either with a grease pencil, or by a strip of paper placed under the record. Both methods are illustrated in Fig. 1.

The fader is then closed, the pickup placed on the disc at the start of lead-in, the tape recorder started, the turntable started, and the fader opened. Normally the fade-in is very rapid, begun just an instant before sound begins. But where the noise is exceptionally great and the music very soft, it is sometimes desirable to "sneak" in with a slow fade, so as to camouflage the rush of surface noise. When this is necessary, several rehearsals should be held until the most pleasing effect is obtained. The same thing is true, of course, of the fade-out, where the sudden disappearance of surface noise is equally annoying.

The dubbing of shellac pressings requires much the same techniques as for lacquer, except that surface noise is a greater factor. Since most of this noise lies in the 3000 to 5000 cycle region, a 4-kc. cut-off will often work wonders in cleaning it up.

The fact that a record is cracked does not necessarily make it useless for rehabilitation. It will often sustain a single play without introducing a once-around tick, particularly if it is patched with adhesive tape on the reverse side. But when ticks cannot be prevented, it will be shown that they may be removed from the tape.

Very often in commercial practice the best available source for dubbing to tape is a metal record known as a *mother* matrix. This is a positive impression of the master, which in turn is a negative of the original. The greatest single problem encountered in getting a good transfer from a mother to tape is *wow*. Very often such a part will be received without any center hole having been punched. Since most studios are not equipped with a means of punching a perfectly centered hole, the only alternative is to make an oversize hole which will allow some freedom of movement, and then to center the disc on the turntable by eye and ear. The visual method consists of sighting along the end of the tone arm from pickup to pivot, and adjusting the position of the mother until no back-and-forth lateral motion is observed. At the same time, a careful listening check should be made, particularly on sustained tones, until no *wow* from this source is noted. There is another source of *wow*, however, which is peculiar to this type of record. Since the several metal layers composing a mother matrix have different expansion coefficients, the record will often be very badly warped. Then various expedients must be resorted to, such as weighting down the center and taping the outer edges to the turntable. Even with such precautions, however, the disc will still exhibit many small ripples which cannot possibly be tracked by a pickup which is loaded by the

mass of the tone arm. This difficulty is neatly avoided by the construction illustrated in Fig. 2, wherein the vertical motion of the pickup is entirely free of the arm in which it pivots. In extreme cases, maximum vertical compliance may be obtained by removing the spring loading entirely and permitting the pickup to "float." The techniques of noise filtering and tone improvement are largely the same as for other types of discs.

The vinylite pressing affords the quietest surface yet introduced to the recording art, but even it has its peculiar sources of noise. One of these is due to dust and dirt, for which the plastic has a strong electrostatic attraction. It is therefore necessary to wipe the surface with a damp cloth in order to remove those foreign particles. An even more annoying source of noise, however, are the ticks which result from tiny holes in the surface. These occur in pressing when minute air bubbles (which in shellac are absorbed into the porous compound) are trapped between the stampers and the biscuit in the press, and leave small depressions in the pressing. The only cure for this is tick-editing of the tape. Since the over-all quality is necessarily dependent upon the original source, the usual filtering and equalizing techniques may often be used to advantage here as well.

Occasionally it is necessary to dub from motion-picture film, as when a television broadcaster desires a better sound to accompany his old films, or when a record manufacturer acquires the rights to music from a movie track. It is vastly preferable that a 35-millimeter print be obtained, rather than 16 millimeter (unless, of course, the job was originally recorded on 16 mm). This will afford better frequency response, better signal-to-noise ratio, and less *wow*. Splices, scratches, and lint are all potential sources of noise, and the print should therefore be as fresh and clean as it is possible to obtain.

The motion-picture industry for many years did little to adopt a standard pre-emphasis characteristic, so the

playback setup here must usually be determined aurally. It will often be found that a high-frequency roll-off will provide a more pleasing sound, and if the hiss level is extremely high, as it usually is on old films, a 4000 cycle cut-off is often necessary. But with such extreme high-frequency attenuation the sound may begin to appear "tubby." At this point some bass must be removed, either by rolling off with an equalizer or cutting off around 100 cycles with a filter. Aside from sprocket-hole noise, which must be corrected by the adjustment of the aperture on the photocell reproducer, the noise reduction efforts for film largely parallel those already described for discs.

Perhaps the greatest of all the many advantages of high-speed magnetic tape recording results from the discovery that small bits may be removed from a length of tape after recording without detriment to the recorded material. Thus any instantaneous noises, such as ticks, clicks, pops, or thumps may be entirely deleted. Care must be exercised, of course, that no more tape is removed than necessary. If this precaution is observed, and if the splice is carefully made, the editing will almost always avoid detection.

Whenever such a noise is heard, the tape should be stopped and rewound to where the noise occurs. The tape is then moved back and forth past the playback head until the noise is precisely located. When it has been marked with a grease pencil, it will usually be found that the tick occupies about a quarter-inch of 30-ips tape, and correspondingly less at slower speeds. The square splice is preferable here, as the diagonal cut removes about 50% more tape. Although this is not a serious factor in speech, it becomes important in some types of music, especially on sustained tones by solo instruments. When a splice of this sort does cause a "skip" to be heard, it can sometimes be improved by the "cut-and-try" method already described in Part 2
(Continued on page 98)

Fig. 2. "Wrist-action" of the Pickering arm allows playing of badly warped discs.

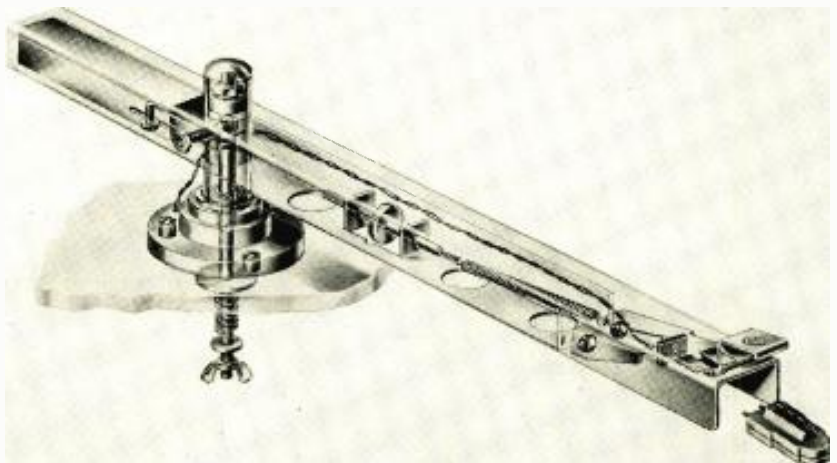

A "BASKET CHASSIS" TRANSMITTER

By

JOSEPH F. SODARO
W6ZRT

Fig. 1. Over-all view of power supply (left) and transmitter (right) built on a "basket chassis"

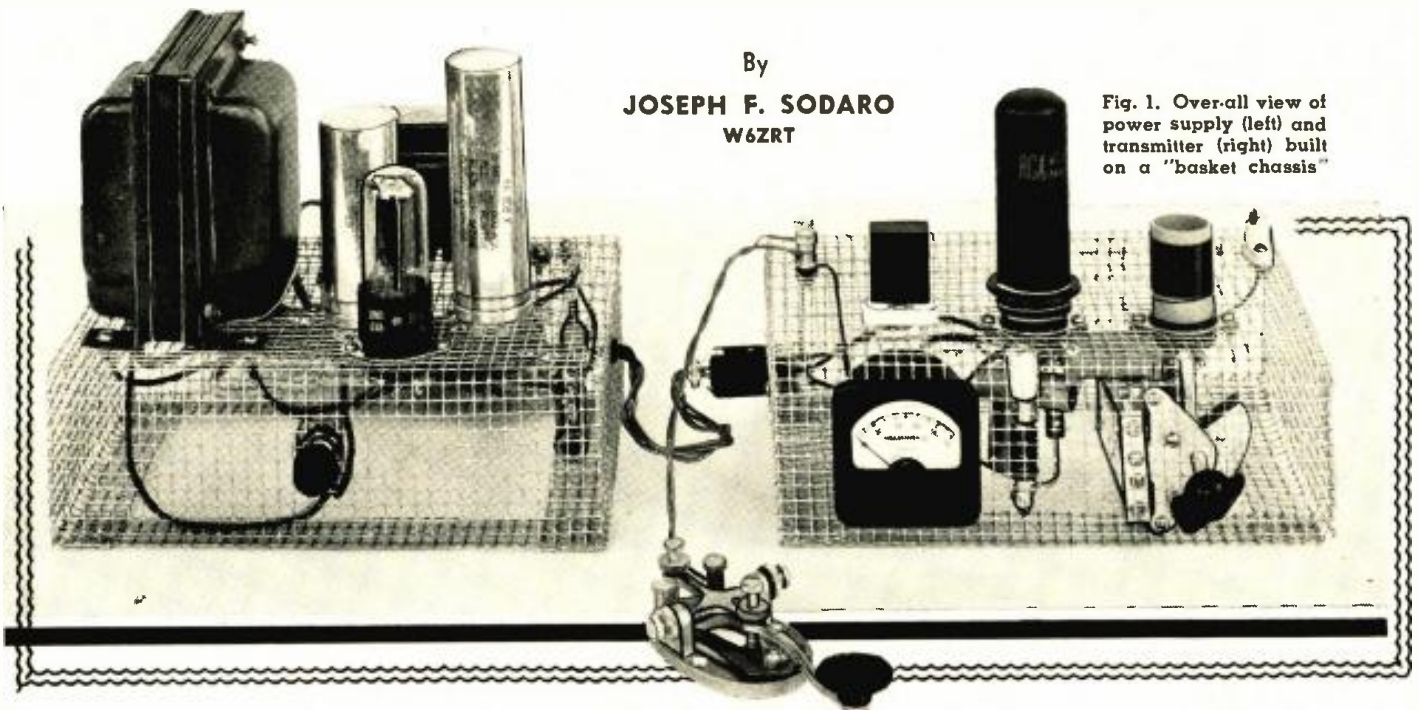

A simple construction technique that can be applied to a variety of experimental projects at minimum expense.

AMONG other problems which confront the newcomer to the amateur ranks is that of equipment construction. He has the choice of either building his first transmitter on a wooden breadboard or on a sheetmetal chassis. The breadboard lacks shielding and presents exposed wiring and shock hazard. Furthermore, some parts cannot be conveniently mounted on this type of chassis without special brackets and angles. On the other hand, the metal chassis requires special tools and a knowledge of the use of these tools. Even when drills, hand-saws, hole punches, and other tools are available there's the problem of irregularly shaped openings which usually require drilling around the periphery of the opening followed by filing. If a prefabricated chassis of suitable dimensions is not available, the sheetmetal cutting and bending problems are added to this complex procedure.

With these problems in mind a search was made to find a chassis material which would simplify electronic equipment construction for those with limited facilities. The basket chassis described in this article was developed and used in the construction of a low power transmitter as a first application. This construction technique requires only simple hand tools and a minimum of effort. It goes together like "a Christmas toy designed for any eight year old boy."

The material used in the construction of the basket chassis is 1/4-inch hardware cloth. This material seems to have the desired electrical and mechanical characteristics. It is easy to cut with tin shears or diagonal cutting pliers. It can be formed by hand and "woven" into a solid structure by bending or wrapping the wire ends using long nose pliers. Mounting holes are simply opened with diagonal cutters. Mounting screw holes and feed-through holes are available everywhere. It is sufficiently continuous to provide electrical shielding at most

Fig. 2. Power supply suitable for use with transmitter described. Any supply which gives 400 volts at 100 ma. can be used.

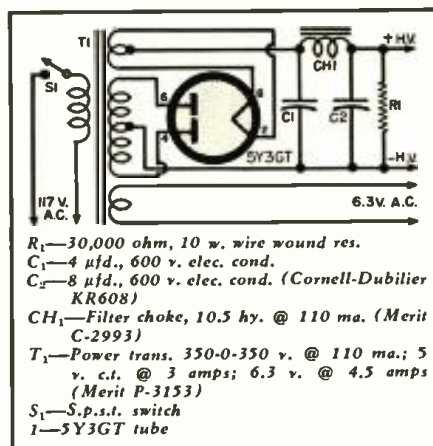

frequencies. It is inexpensive and readily available.

Although any size hardware cloth can be used, the 1/4-inch spacing probably gives maximum strength and shielding without excessively close wire spacing. The cross-hatch design is helpful in layout, and the 1/4-inch units afford an approximate measure which is often adequate for parts location.

Parts mounting and hookup is simpler with the basket chassis because this process can be observed through the loops in the hardware cloth. This transparency eliminates dark corners and permits a higher concentration of parts. In addition this feature allows the observance of almost all parts on either side of the chassis during proven. Thus, overheating or arcing can be quickly detected. Furthermore, this feature makes the equipment particularly well suited for demonstration or instruction purposes. Finally, the mesh material allows better ventilation.

Chassis Construction

The only tools required for the construction of the chassis are tin shears, long nose pliers, and diagonal cutters. As a first step, the material is cut to size. For the 9-inch by 6-inch chassis used for this transmitter and power supply the over-all dimensions are 17 inches by 14 inches. This allows three inches for depth and one inch for a flange. In this first cut the material should be close trimmed to remove all wire stubs. In the second cut remove four inch squares from the four corners. In this case maximum wire stub length is allowed. These stubs

are later used to weave the corners together.

Next, bend up the one inch flange at right angles as shown in Fig. 3. The line of bend can be made straight by following the wire one inch from the edge. The edge straightness and sharpness can be improved by working against a wooden block as shown in this photograph. For the chassis shown, hending was done entirely by hand. Edge sharpness can be further improved, if desired, by using a light hammer.

After the chassis has been bent to approximate shape the corners can be formed. Draw together those wires which will form the vertical edge of the chassis, and wrap around the wire stubs so as to fix this edge. Repeat this procedure for each corner. The overlay of the flange can be fixed in the same way with stubs wrapped about either horizontal or vertical wires. The transmitter chassis was completed from sheet material in 45 minutes.

Heavy components were mounted on the power supply chassis without excessive sag. However, if in a larger size chassis this should become a problem, the surface can be reinforced with small stiffeners at the points of weight concentration.

Screen compartments can be added in a similar manner, if desired. For example the transmitter coil can be shielded by a hardware cloth enclosure. Similarly, sections of the chassis could be isolated by weaving in hardware cloth enclosures. Another possibility would be the addition of a front panel if desired. The only precaution to observe in designing these adjuncts is that of allowing stub length wherever a joint is to be made to the chassis proper.

Transmitter Construction

The transmitter is a 6L6 in a conventional crystal oscillator. The schematic and parts list are shown in Fig. 4. Shunt feed is used to keep high voltage within the chassis. A 0-100 mil-

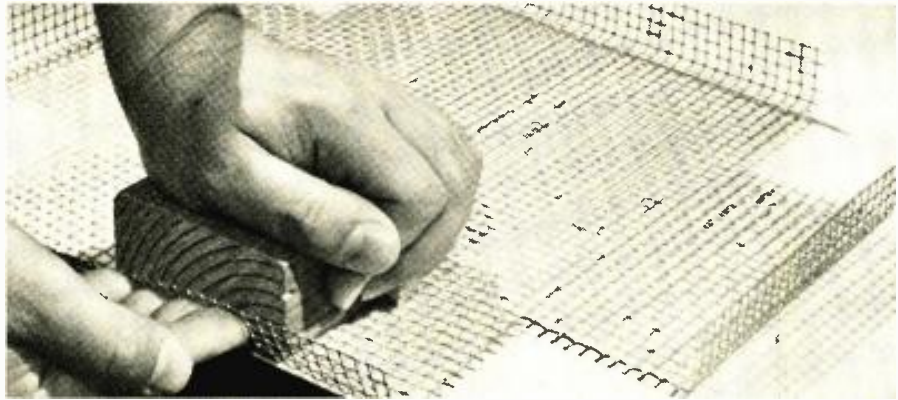

Fig. 3. How the chassis flange can be formed by hand by bending the material against a wooden block. If unusually heavy components are to be mounted on a "basket chassis" stiffeners, in the form of additional pieces of the hardware cloth, may be fixed to the chassis by working the wire stubs into the chassis surface. These structures could also be used to form shielded compartments within the chassis proper.

liammeter is used for tuning and loading indications. The plate circuit coil is tapped for coupling to a simple voltage feed antenna. Keying is in the negative high voltage lead. Any power supply capable of approximately 400 volts at 100 milliamperes with good regulation and 6.3 volts at 0.9 ampere can be used. A power supply, Fig. 2, has been included for those who wish to build one.

The power supply uses a full-wave rectifier and simple filter with bleeder resistor. The schematic and parts list for the power supply are shown in Fig. 2.

Construction

The arrangement of component parts is shown in Fig. 5. First, lay out the parts for short lead length, then make the openings for mounting. Openings are cut by means of diagonal cutters. No difficulty was encountered in opening mounting holes for any of the parts. The tube and crystal sockets were held on the opposite side while openings were cut. By this means each opening was cut to the required shape without outline markings.

Parts were mounted with 6-32 or

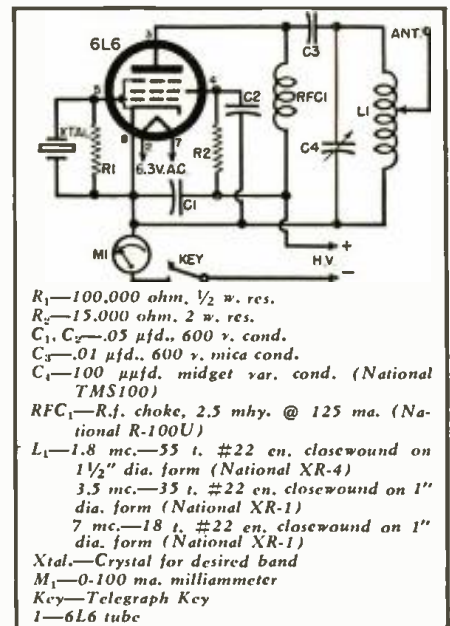
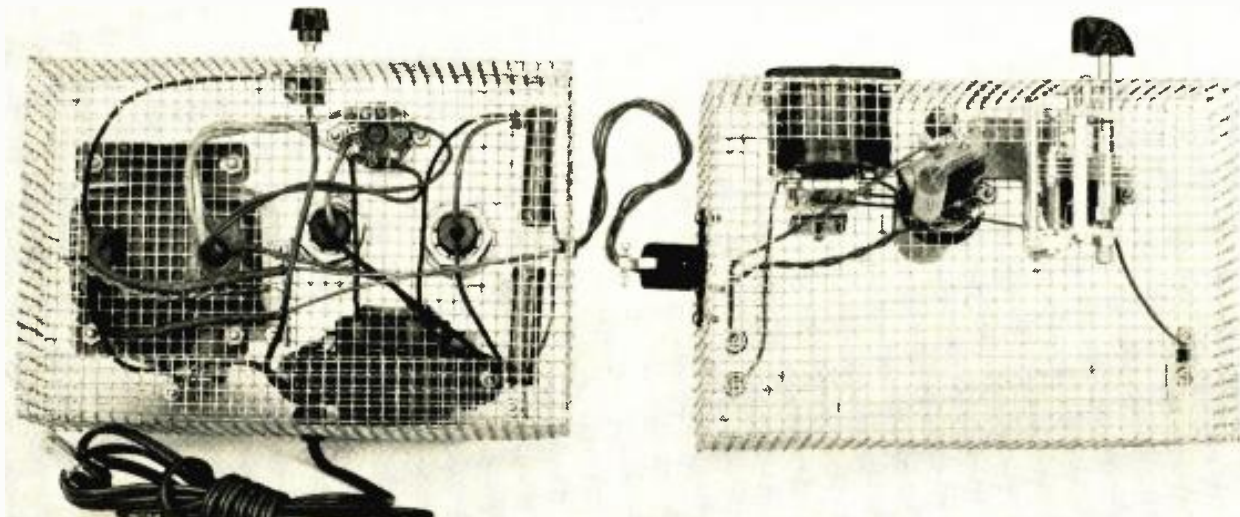

Fig. 4. Schematic of the low power transmitter which can operate on 1.8 mc., 3.5 mc., or 7 mc. See Fig. 2 for power supply.

8-32 machine screws of $\frac{3}{8}$ to 1 inch
(Continued on page 107)

Fig. 5. Underchassis view of the transmitter power supply built on a "basket chassis." This technique simplifies construction throughout.



THE Compleat FIDELITY

THE EQUALIZER

By **DON V. R. DRENNER**
Engineer, Station KGGF

In the first two parts of this series, we discussed the "Compleat Fidelity" system and its speaker enclosure and the television tuner associated with the unit. Finally, we will cover a few changes which were made on the AM-FM tuner.

The tuner of the "Compleat Fidelity"

is a *Craftsmen* RC-10 AM-FM unit that served for several years in a small cabinet. When the basic idea for building all the gear into a wall crevice was conceived, we decided to modify the phono preamp section of the RC-10. Not that most of our LP's didn't sound quite good, but the single

Part 3. Construction details on a variable equalizer that can be added to a *Craftsmen* Model RC-10 AM-FM receiver.

triode originally used has a compromise turnover frequency and besides we're a firm believer in using a feedback path to control frequency.

Several circuits were tried, haywire style, until we found the Geo. F. Jones variable equalizer circuit in *Audio Engineering* for January 1952. Using this meant finding room for another socket and two additional controls.

The schematic shows how we did it. A pair of 1N34 germanium diodes replaced the original 6AV6 diode-triode and gave us a second detector and a.v.c. The socket used by the 6AV6 was removed and a novel installed for the dual-triode 12AT7 of the equalizer. Even though we would have preferred an extra socket and an infinite impedance detector, there just wasn't room.

The high and low frequency tap switches presented quite a problem until we hit on an idea from the TV chassis. Concentric-type potentiometers, such as used for the "volumetone" control on most TV sets offered the solution. The original treble and bass controls of the RC-10 were replaced by these concentric controls, and this allowed a small miniature tap switch, manufactured by *Grayhill*, to be mounted at the rear of the front control section. Thus, the treble control varies the preamp and the tone-control amplifier through the split knob actuating either the potentiometer or the tap switch. The same thing applies to the bass.

So we got our variable equalization and kept the controls on the front of the RC-10 intact!

One caution, however. The treble control is mounted very close to the antenna coil of the FM preamp (L₁ of the 6AB4 grounded-grid stage). This is a broadband circuit and the turns spacing and original position of this coil should be the same after the new control and switch are installed. Otherwise, a realignment job with a signal generator is in order. Needless to say, this expedient should be avoided if possible since many home builders and audiophiles just don't have such equipment available nor can they borrow it.

While the changes suggested in these articles were for specific pieces of equipment, there is no reason why similar alterations cannot be made in the equipment the reader has on hand to integrate his system to provide the "Compleat Fidelity" for his own home.

Fig. 1. (A) Original circuit of the RC-10. (B) Circuit changes to incorporate 1N34's instead of a 6AV6. (C) The "Jones" variable equalizer circuit used by the author.

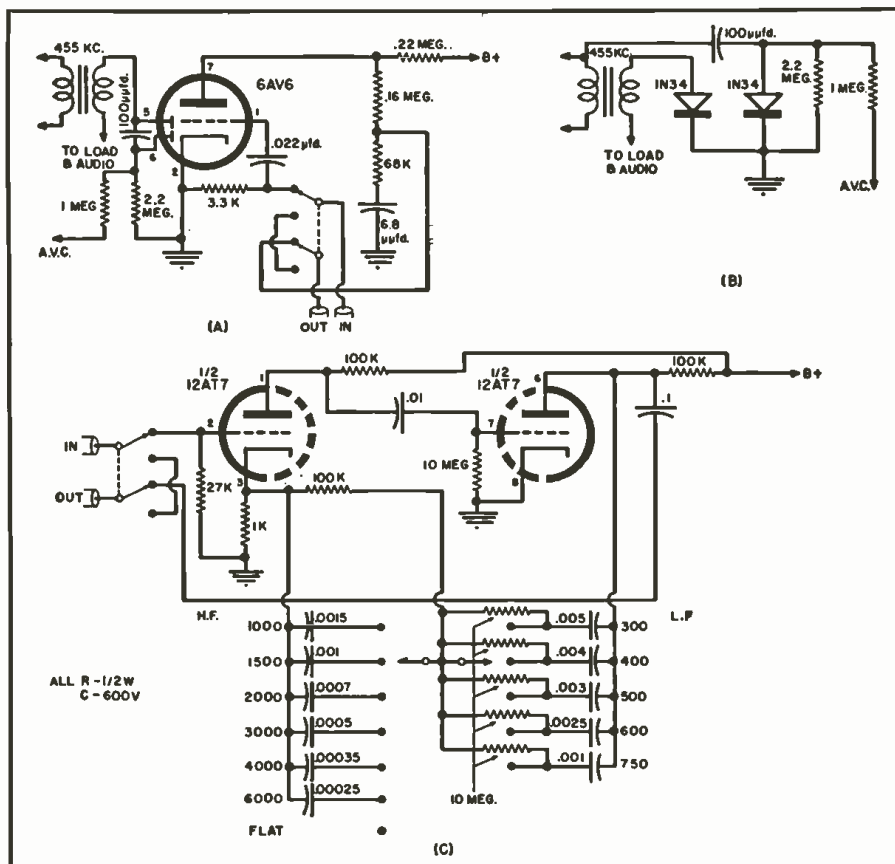

KNOW YOUR 1954

MOTOROLA TV RECEIVERS

By
SERVICE & ENGINEERING DEPARTMENTS
Motorola Incorporated

THE new *Motorola* chassis TS-602 features several distinct changes from the previous models. The most significant of these are the moving of the secondary controls to the front of the chassis, and the switch to the 40-megacycle i.f.

This discussion of the chassis will concentrate on the new circuits rather than describe those which have been used until now and are fairly well known. These new circuits include the a.g.c. system, sync clipper and noise gate, and the area selector switch.

Amplified A.G.C. System

The amplified a.g.c. system used in the TS-602 is an improved version of keyed a.g.c. in that the resultant a.g.c. voltage has better stability over a wider range of incoming signals. It does not require the exact synchronization between the peaks of the composite video pulses and the horizontal pulses that is necessary in the conventional keyed a.g.c. circuit.

The tubes used for the development of the a.g.c. voltages in the TS-602 chassis are the first sync amplifier V_{11A} , the a.g.c. tubes V_{11A} and V_{11B} , and the limiter clamper for the radio-frequency a.g.c. voltage V_6 .

The first sync amplifier, V_{11A} , being directly coupled from the second detector (see Fig. 3), amplifies the information for the a.g.c. as well as the sync information. For a peak a.g.c. system, the a.g.c. information is represented by the voltage relationship between the sync pulse tips and a d.c. reference level (zero volts in this particular circuit). The sync pulse tips extend away from zero in a negative direction. After the sync and a.g.c. information is amplified by the sync amplifier, V_{11A} , the phase is reversed and the sync pulses extend away from zero in a positive direction.

Before the a.g.c. information can be applied to control the receiver gain, it must be converted to a negative d.c. voltage. This is accomplished in the a.g.c. tube, V_{11B} . The cathode of this tube is connected to a fixed positive

Fig. 1. Rear view of the new *Motorola* TS-602 chassis showing the lack of rear apron adjustments.

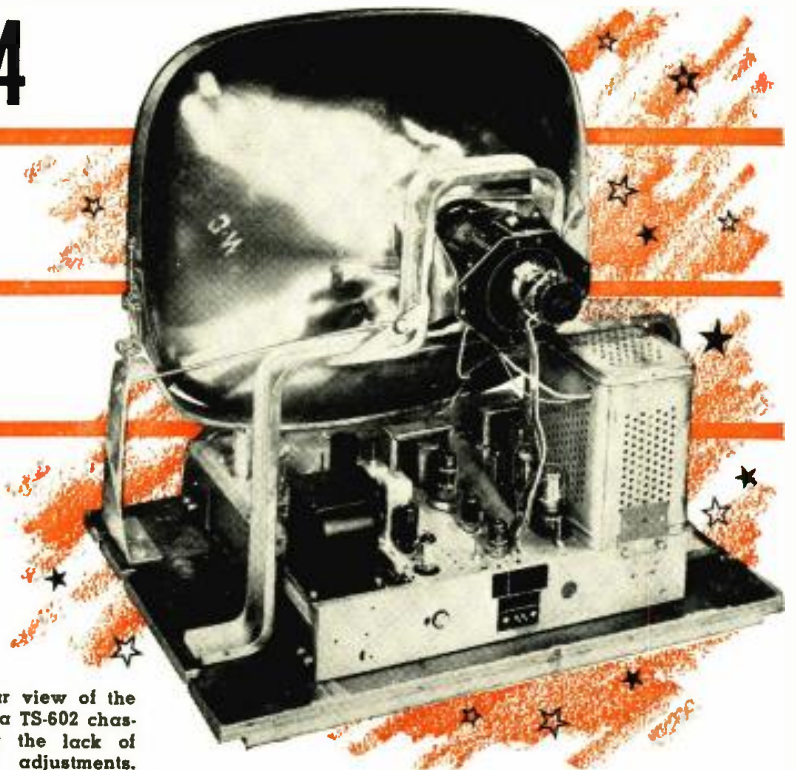

Circuit operation and complete service data for the new Motorola TV sets, including alignment instruction table.

reference potential of 150 volts derived from "B+". The grid is supplied with the peak sync pulse information through tube V_{11A} . The effect of V_{11A} is shown in Fig. 2A, the grid voltage representation. The dotted line is the signal on the grid of V_{11A} , and the heavy solid line is the signal on the cathode of V_{11A} , which is coupled to the grid of V_{11B} . V_{11A} is a peak-detecting cathode follower because the cathode can follow increases in grid voltage, but the time constant (R_{11} and C_{11}) in the cathode does not allow it to follow the decreases. Thus, due to plate current flow, the cathode potential rises rapidly with the leading edge of the sync pulse and follows up to the peak. But when the grid voltage falls rapidly on the back end of the sync pulse and plate current drops, the voltage on the cathode of V_{11A} can only fall at the discharge rate of the RC ground return circuit (R_{11} and C_{11}). This accounts for the result-

ant saw-tooth of voltage coupled to the grid of V_{11B} .

It is important to note two items in Fig. 2. One, the potential difference between the fixed reference level and the sync pulse peaks still represents the a.g.c. information. Two, this potential difference is converted to a saw-tooth by the action of V_{11A} and this saw-tooth, being directly coupled to the grid of V_{11B} , controls the bias of that tube. Therefore, the plate current conduction of V_{11B} will be determined by the a.g.c. information.

The plate voltage for V_{11B} consists of a series of horizontal-rate pulses coupled through C_{11} from the horizontal output circuit (Fig. 2B). During the time the pulse is present on the plate of V_{11B} , plate current will flow (provided the a.g.c. information applied to the grid calls for conduction). This plate current is the discharge current of C_{11} . As condenser C_{11} is discharged, it will draw charging current through the two plate resistors. The voltage drop across these resistors causes the average potential at the plate to be negative. The voltage across the lower resistor is filtered by C_{12} to give a negative d.c. voltage for a.g.c.

It should be noted here that the action of V_{11B} would be substantially the same whether the sync pulses in the a.g.c. information were made into saw-tooth signals or not. If the sync pulses were passed on to the grid of V_{11B} as pulses, and not in the form of a saw-tooth, coincidence of the grid and plate pulses in V_{11B} would be neces-

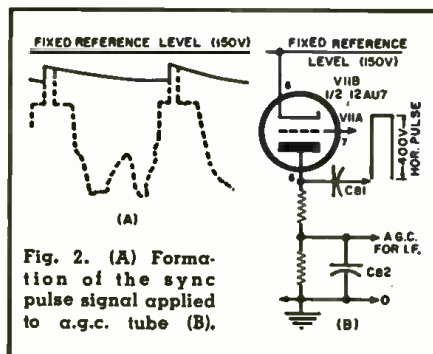
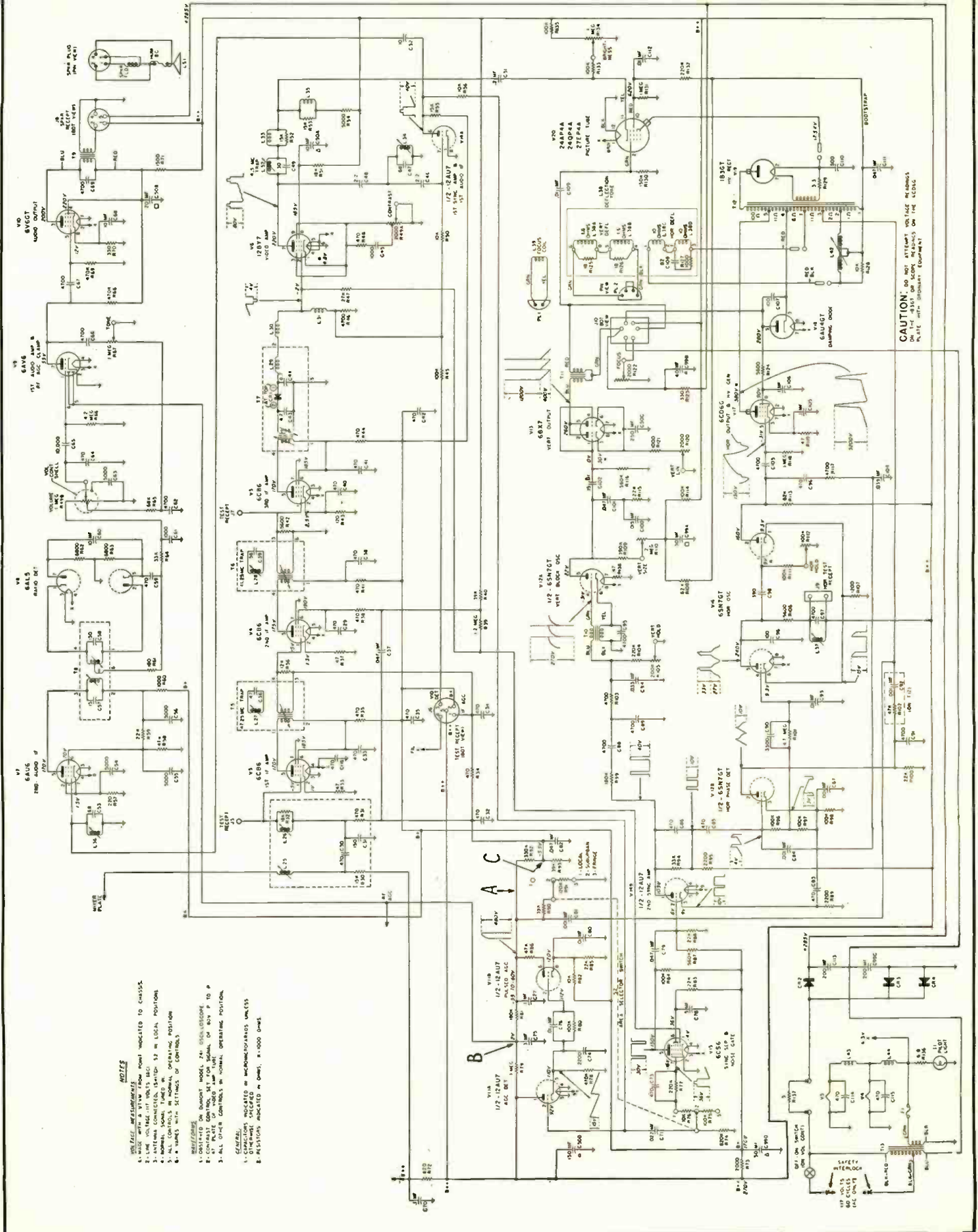

Fig. 2. (A) Formation of the sync pulse signal applied to a.g.c. tube (B).

Fig. 3. Complete schematic diagram of the Motorola TS-602 TV chassis without the tuner. The schematic diagrams of the v.h.f. and u.h.f. tuners used with this chassis are shown in Figs. 5 and 6 respectively.



- NOTICE**
- WARRANTY MEASUREMENTS**
1. ANTENNA CONNECTION: IS-TUNER: 12 IN LOCAL POSITION.
 2. ANTENNA CONNECTION: IS-TUNER: 12 IN LOCAL POSITION.
 3. ANTENNA CONNECTION: IS-TUNER: 12 IN LOCAL POSITION.
 4. ANTENNA CONNECTION: IS-TUNER: 12 IN LOCAL POSITION.
 5. ANTENNA CONNECTION: IS-TUNER: 12 IN LOCAL POSITION.
 6. ANTENNA CONNECTION: IS-TUNER: 12 IN LOCAL POSITION.
- GENERAL**
1. DISTORTION: NEGATIVE IN MONITORING UNITS.
 2. DISTORTION: NEGATIVE IN MONITORING UNITS.
 3. DISTORTION: NEGATIVE IN MONITORING UNITS.
 4. DISTORTION: NEGATIVE IN MONITORING UNITS.
 5. DISTORTION: NEGATIVE IN MONITORING UNITS.
 6. DISTORTION: NEGATIVE IN MONITORING UNITS.

sary to make the tube conduct. The saw-tooth on the grid of V_{11B} keeps the grid in conduction range so that exact coincidence is not necessary to get the full benefit of the a.g.c. action. If pulses were used on the grid of V_{11B} , at the ends of the horizontal hold range or, if the receiver goes out of sync, the lack of complete coincidence would cause less-than-normal a.g.c. to be developed. This would result in contrast changes with the horizontal hold setting and reduce the horizontal pull-in range. These undesirable effects are eliminated by use of the saw-tooth.

If the same a.g.c. voltage could be used for r.f. as well as i.f. bias, the filtering circuit of Fig. 2B would be sufficient. However, it is desirable to have the application of the r.f. bias delayed until several volts of i.f. bias have been developed, and then have

the r.f. bias rise as rapidly as possible after the delay has been overcome. This is because the r.f. bias must meet two requirements. First, it must not reduce the gain of the r.f. amplifier until the signal level has risen to such an extent that the noise introduced by the converter need not be overridden by the r.f. amplifier gain. (It is possible to have the r.f. tube, the converter stage and, possibly, even the first i.f. tube introduce noise into the circuit. Generally, the design of the circuit around the r.f. tube calls for the best possible noise factor with at least 5:1 gain. Such results will provide the converter stage with enough clean signal so that it can amplify cleanly. If the r.f. tube has less gain than about 5:1, then the noise introduced by the converter stage becomes appreciable, relative to the television signal especially since a pentode is

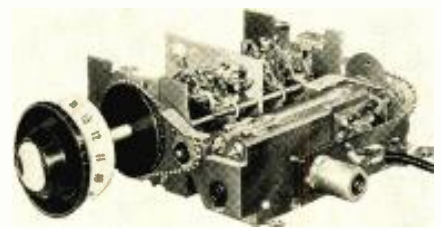

Fig. 4. The Motorola "Robot-82" tuner. The v.h.f. part is at left. u.h.f. right.

used in this circuit. This would hold true even though the television signal received at the TV set antenna terminals was fairly strong.)

The second requirement of the r.f. bias is that it must reduce the gain of the r.f. amplifier sufficiently on strong signals so that the converter is not overdriven. Reference to Fig. 3 will

Table 1. Alignment procedure for the video i.f., 4.5 mc. trap. and sound circuits of the Motorola TS-602 TV chassis.

VIDEO I.F. ALIGNMENT						
STEP	SIGNAL GENERATOR		OUTPUT INDICATOR	CONNECT TO	ADJUST	REMARKS
	FREQUENCY	CONNECT TO				
1	44 mc., 12 mc. sweep	Test receptacle J_7 through a 1000- μ fd. condenser	Oscilloscope	Pin 3 of test receptacle J_6	Primary and secondary of T_7 for symmetrical response curve	See Fig. 8 for location of test receptacles
2	45.75 mc., 12 mc. sweep	Test receptacle J_8 through a 1000- μ fd. condenser	Oscilloscope	Same as above	T_8 to place 45.75 mc. marker 30% down from maximum on high side of curve	
3	42.25 mc., 12 mc. sweep	Same as above	Oscilloscope	Same as above	T_6 to place 42.25 mc. marker 30% down from maximum on low side of curve	
4	47.25 mc., 12 mc. sweep	Same as above	Oscilloscope	Same as above	L_{27} for maximum attenuation at 47.25 mc.	
5	41.25 mc., 12 mc. sweep	Same as above	Oscilloscope	Same as above	L_{28} for maximum attenuation at 41.25 mc.	
6	44 mc., 12 mc. sweep	Test receptacle J_9 through a 1000- μ fd. condenser	Oscilloscope	Same as above	L_{25} and L_{26} for response curve below:	
4.5 MC. TRAP ALIGNMENT						
7	4.5 mc. unmodulated	Top of detector load, R_{46} , and chassis	V.T.V.M. and crystal detector probe	Cathode of CRT (pin 11) and chassis	L_{32} for minimum reading	
SOUND I.F. AND RATIO DETECTOR ALIGNMENT						
8	4.5 mc. unmodulated	Top of detector load, R_{46} , and chassis	V.T.V.M.	One side of C_{60} and chassis	L_{36} for maximum reading	Set meter on 5-volt scale
9	4.5 mc. unmodulated	Same as above	V.T.V.M.	Same as above	L_{34} and primary of T_8 (top) for maximum reading	
10	4.5 mc. unmodulated	Same as above	V.T.V.M.	Junction of R_{64} and C_{61}	Secondary of T_8 (bottom) for zero	



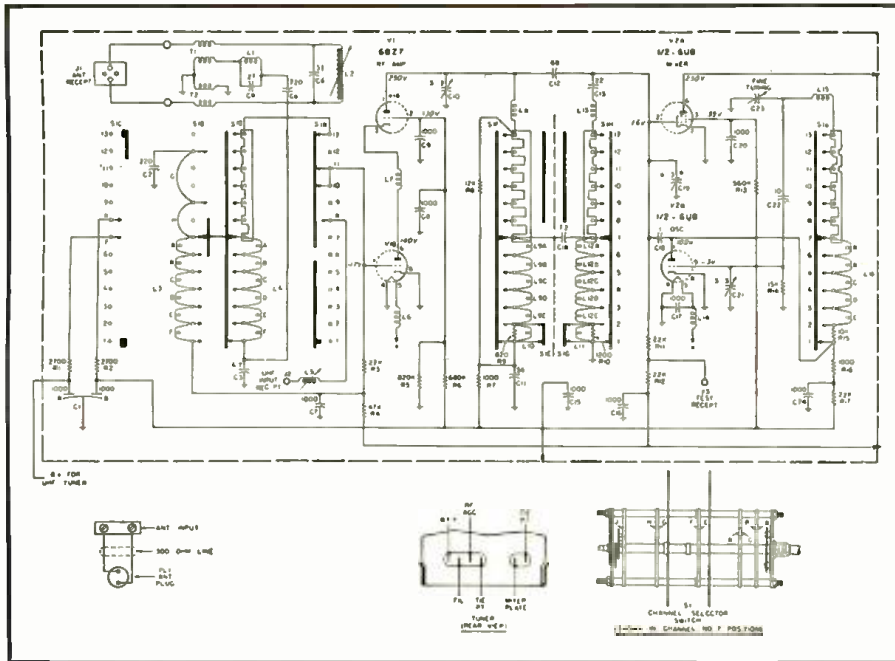

Fig. 5. Schematic diagram of the v.h.f. tuner used with the Motorola TS-602 chassis.

show how the desired r.f. and i.f. bias is obtained. The 47,000-ohm resistor (R_{40}) between the plate of the a.g.c. amplifier (V_{11B}) and the a.g.c. voltage divider network is only a decoupling resistor for the a.c. pulse on the plate, and is relatively unimportant for d.c. consideration. The four resistors, R_{79} , R_{81} , R_{92} , and R_{93} are important, and determine the value of the r.f. and i.f. bias voltages.

Although the high side of R_{79} is tied to "B + +" (270 volts) for delay purposes, the low side of R_{79} , at the junction of R_{81} and R_{79} , cannot go positive to any extent on weak signals because point "B" is tied to the plates of the twin diodes of V_9 (6AV6). Since the cathode of V_9 is tied to ground, any positive voltage appearing at point

"B" would cause conduction and keep the potential at point "B" close to ground. Since point "B" is the take-off for the r.f. bias, it can be realized why it is undesirable to have a positive voltage there. However, point "B" can go in the negative direction from ground or zero potential after a certain amount of negative a.g.c. voltage is developed at point "A".

When point "A" has about -48 volts, due to the action of the a.g.c. amplifier, point "C" will be about -5.1 volts due to the voltage divider network of R_{92} and R_{93} . Point "B" will still be near zero volts, due to the voltage divider network of R_{81} and R_{79} , and the damping diodes. When the negative voltage at point "A" goes more negative (beyond -48 volts),

Fig. 6. Schematic diagram of the all-channel continuous Motorola TT-37 u.h.f. tuner.

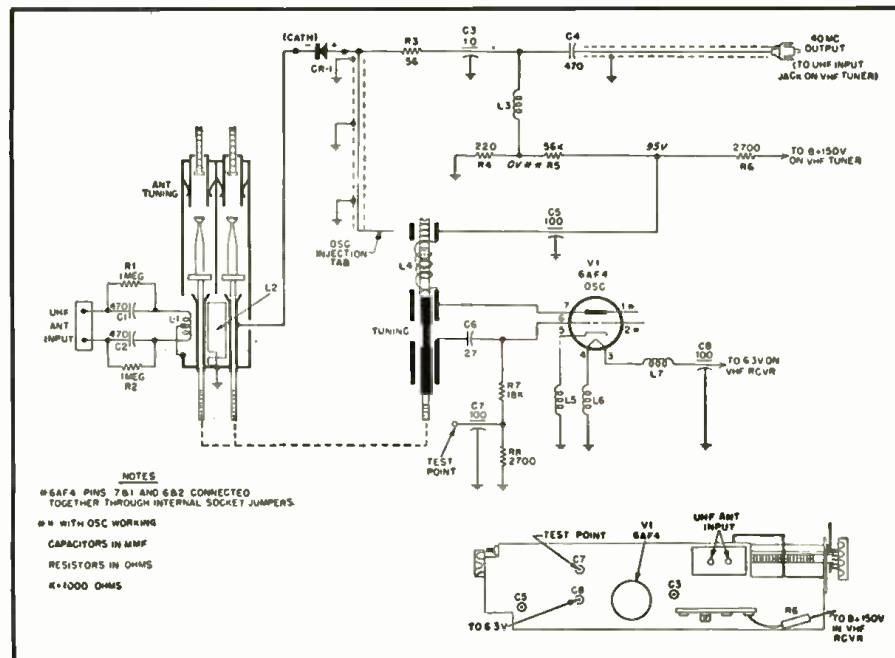

NOTES
 * 6AF4 PINS 7B1 AND 6B2 CONNECTED TOGETHER THROUGH INTERNAL SOCKET JUMPERS.
 ** WITH OSC WORKING
 CAPACITORS IN MMF
 RESISTORS IN OHMS
 R=1000 OHMS

the i.f. bias at point "C" still rises slowly due to the voltage divider network of R_{92} and R_{93} . But the voltage at point "B" will increase in the negative direction almost as fast as the voltage at point "A". For a 1-volt increase in the i.f. bias, there will be about 8-volts increase in r.f. bias on strong signals. Note that all "B+" and "B + +" voltages in these circuits are common.

Servicing the A.G.C. System

Improper a.g.c. action will fall into one of three general categories:

1. Insufficient a.g.c.
2. Excess a.g.c.
3. Improper division between r.f. and i.f. bias

The insufficient a.g.c. condition will be evidenced in the picture in various ways depending on the degree of insufficiency. If there is no a.g.c. developed, the contrast will increase rapidly as the signal increases from a low level. The synchronization will be unstable on weak signals and very poor on slightly stronger ones. On strong signals, the picture may reverse and appear as a negative or go completely black. If some a.g.c. is developed, but not enough, the set may exhibit overload tendencies on strong signals, but the effects will not be as severe as when no a.g.c. is being developed.

Too much a.g.c. is evidenced by a lack of available contrast or, in extreme conditions, by a complete lack of picture at any signal level.

Checking for the development of proper a.g.c. voltage can best be done by measuring the voltage at the top of the a.g.c. dividing resistors, the junction of R_{81} and R_{92} (point "A") with a v.t.v.m. With a normally strong signal, the voltage at this point should read about -60 volts. A voltage reading considerably higher than this would indicate a short or open on one of the a.g.c. buses, or a short in the a.g.c. amplifier tube. A voltage considerably lower than this could indicate several things such as:

1. Lack of sufficient second detector signal due to a failure of the tuner or i.f. amplifier. Check by measuring the d.c. at the second detector. It should exceed -2 volts.

2. Lack of a.g.c. referencing pulse. Check with a scope on the plate of the a.g.c. amplifier, or touch this point with an insulated handle screwdriver and watch for a small spark. Also, short the grid to the cathode on the a.g.c. amplifier with a screwdriver. The voltage at pin 6 of V_{11B} should rise to about -100 volts. This indicates the proper plus voltage and a good a.g.c. amplifier tube.

3. If the second detector voltage is highly negative and the a.g.c. tube develops -100 volts or more when the grid and cathode are shorted together, the trouble is in the sync amplifier and associated circuits, or in the cathode circuit of the a.g.c. amplifier. The cathode voltage should be about 150-volts positive on strong signals.

Improper division between r.f. and

i.f. a.g.c. voltages will show up on strong signals. If the picture is snowy on strong signals, it may be due to too much r.f. a.g.c. for that signal level. This can be checked by shorting the r.f. a.g.c. bus to ground or shunting it to ground with a 10,000-ohm resistor. If the snow clears out with reduced r.f. bias, the a.g.c. dividing resistors should be checked for proper value. Also, if either the r.f. or i.f. a.g.c. bus is shorted to ground, the unshorted bus will attempt to control the receiver gain. This will be evidenced by extremely snowy pictures on all signals if the i.f. a.g.c. is shorted, and by overload on strong signals if the r.f. a.g.c. is shorted.

Sync Clipper Noise Gate

The positive-going composite detected video signal is taken from the plate of the first sync amplifier tube V_{11A} and coupled to the 1st sync clipper stage V_{15} through C_{71} (.022 μ f.). The grid return of V_{15} to ground is through R_{71} (820,000 ohms) plus R_{76} and R_{75} , depending on the setting of the area selector switch.

C_{73} and R_{71} form a noise dissipating circuit which differentiates high amplitude noise pulses. On a scope, the noise burst would ordinarily show up as a high amplitude pulse extending up through the "black region" of the composite video signal showing a saturated pulse. When differentiated, the front edge of the noise pulse would still extend into the black region, but it would be narrower and then, where the trailing edge of the original pulse took place, the differentiating circuit shows a sharp narrow pulse into the "white region."

The positive-going composite pulse that hits the grid of the first sync clipper V_{15} makes this tube conduct. The amplitude of the incoming pulse (about 40 volts) is enough to draw grid current. The grid is held negative at about 16 volts due to the value of the grid bias resistor, R_{71} . The grid bias, therefore, initiates the clipping action because the following composite video pulses first have to overcome the negative bias on the grid to make the tube (V_{15}) conduct.

Since heavy noise pulses could enter the circuit along with the composite video signal and charge up the grid condenser C_{71} so heavily that the tube could not conduct during the sync pulses, a "noise gate" has been incorporated into the circuit. V_{15} is a heptode (pentagrid converter) and, therefore, has two controlling grids. A negative-going composite video pulse is taken from the 2nd detector output and fed to the first control grid (pin 1) of V_{15} . This grid is so biased that a normal detected signal (which is held at a constant amplitude of 4 volts or less by the action of the a.g.c. circuit) will not stop V_{15} from conduction but, when noise bursts of higher amplitude than the detected signal come through the second detector, these noise bursts or pulses will be negative enough to cut off V_{15} . If V_{15} is cut off

by grid 1, then the same noise bursts cannot draw extra grid current through the second control grid (pin 7) and charge up C_{71} , even though the noise bursts have been amplified by the first sync amplifier, V_{11A} . When the noise burst subsides and control grid 1 allows the tube to conduct again, the second control grid (pin 7) has the normal amount of bias. Thus, the action of the noise gate grid creates a hole in the sync train, but the sync holds stability due to the flywheel action of the horizontal sync generator in the multivibrator (V_{16}) circuit.

The negative-going sync pulse in the plate circuit of V_{15} is coupled to the grid of V_{11B} , the 2nd sync amplifier, where it is clipped both on top and bottom, so that the resultant pulse in the output has the desirable amplitude and shape.

Area Selector Switch

One section of the area selector switch is connected into the plate return circuit of V_{11B} , the a.g.c. amplifier (see Fig. 3). In checking the local position of the area selector switch, it will be noted that all of the a.g.c. plate current flows through both the r.f. and the i.f. a.g.c. dividing resistors, R_{70} , R_{81} , R_{92} , R_{93} . However, in the suburban position, resistors R_{90} and R_{91} are placed in shunt with the a.g.c. dividing resistors. This reduces the gain of the a.g.c. tube somewhat, thereby reducing the maximum a.g.c. that can be developed. Thus, a high energy noise can now develop less unwanted a.g.c. voltage than with the switch in the local position.

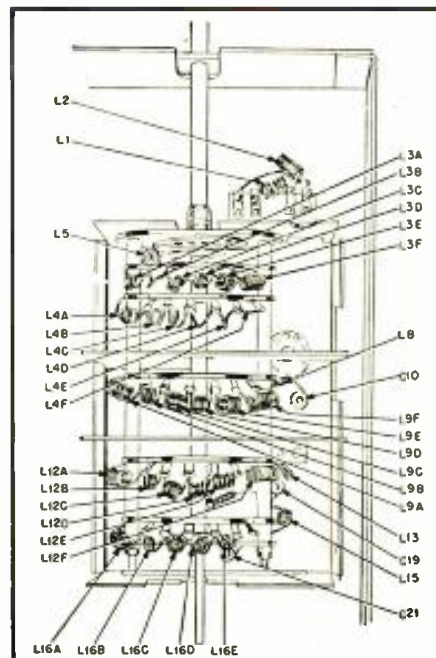
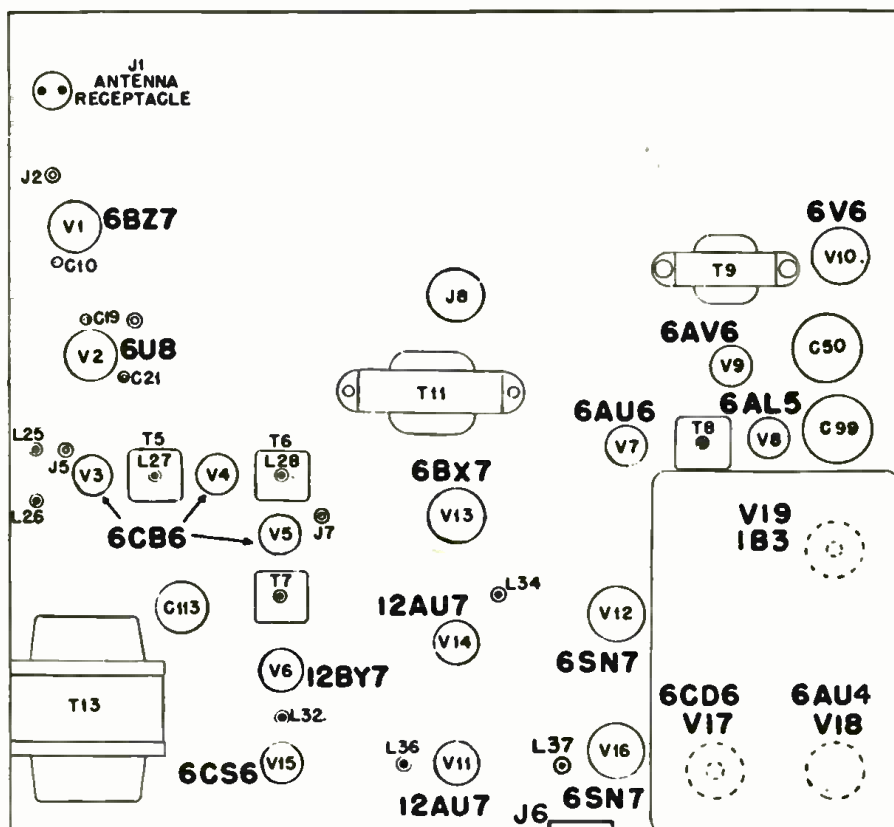

Fig. 7. Motorola v.h.f. switch-type tuner showing the various switch wafers and adjustment locations.

In the fringe position, only resistor R_{90} shunts the a.g.c. dividing resistors, still further reducing the available a.g.c. voltage. Since these resistors are switched in for noise immunity reasons, no marked effect on contrast occurs unless the switch is moved into the suburban or fringe position under strong signal conditions.

The other section of the area selector switch is connected into the plate return circuit of V_{11B} , the a.g.c. amplifier (see Fig. 3). In checking the local position of the area selector switch, it will be noted that all of the a.g.c. plate current flows through both the r.f. and the i.f. a.g.c. dividing resistors, R_{70} , R_{81} , R_{92} , R_{93} . However, in the suburban position, resistors R_{90} and R_{91} are placed in shunt with the a.g.c. dividing resistors. This reduces the gain of the a.g.c. tube somewhat, thereby reducing the maximum a.g.c. that can be developed. Thus, a high energy noise can now develop less unwanted a.g.c. voltage than with the switch in the local position.

Fig. 8. Top view of the Motorola TS-602 chassis showing tube layout and parts.



A TRANSISTOR METRONOME

By

LOUIS E. GARNER, JR.

MECHANICAL metronomes are known to almost every musician and student of music and have been in use for perhaps two centuries or more. In their simplest form they consist of a pivoted pendulum with one fixed and one movable weight. The position of the movable weight determines the number of oscillations or "beats" per minute when the pendulum is set in motion. More complicated versions employ a clockwork mechanism to drive the pendulum, and it is this version that is perhaps the best known.

In modern times, electrical and, later, electronic metronomes have seen wider use. Today, electronic metronomes are probably more widely used than the mechanical versions because of their lower cost, ease of setting, and ready availability. A number of articles have appeared giving construction information on such units.

Most electronic metronomes suffer from a disadvantage not shared by the mechanical units—they require a line power source. Power may not always be available or convenient to the musician in his "working" location. Battery operated metronomes have, in the past, not proven too satisfactory because of the large and heavy batteries required to deliver reasonable "loudspeaker" volume from vacuum tube operated equipment, as well as the comparatively short battery life obtained.

Today, however, with the ready availability of the highly efficient transistor, it becomes practicable to design and build a battery operated electronic metronome that is simple, compact, reliable, light in weight, and comparatively low in cost, yet delivers sufficient power to give a distinct "beat" of sufficient loudspeaker volume for all normal use.

The "Transistor Metronome" designed and built by the author is shown in Fig. 1. Standard, easily available components are used throughout. The average technician should have little or no difficulty in assembling and wiring a similar or duplicate unit in a few evenings' time.

Circuit Description

A Raytheon CK722 junction transistor is used in a modified grounded emitter "tickler feedback" oscillator circuit, as can be easily seen by refer-

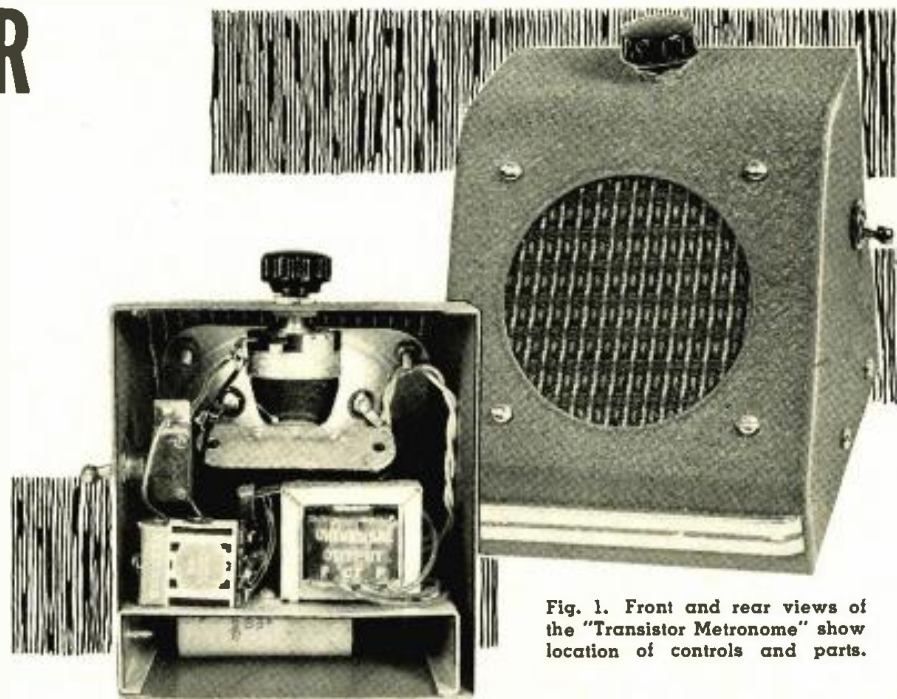

Fig. 1. Front and rear views of the "Transistor Metronome" show location of controls and parts.

In addition to its obvious application as an aide to musical studies, this instrument can double as a photo timer for the darkroom or as a mechanical process timer.

ence to the schematic diagram, Fig. 2. A standard "universal" audio output transformer, T_1 , serves both to provide the feedback necessary to maintain oscillation and to drive the small $3\frac{1}{2}$ " PM loudspeaker.

In operation, the start of a current flow in the collector circuit and through the primary of T_1 induces a signal across the secondary winding of the transformer. This signal, in turn, causes C_1 to charge rapidly through the base-emitter circuit of the transistor and the secondary winding of T_1 .

As C_1 starts to charge, the resulting base current flow permits an increase in the collector current flow, thus increasing the signal amplitude in the secondary winding of T_1 . The net effect is cumulative, with both base and collector currents reaching a peak as C_1 charges.

The voltage across C_1 soon reaches its maximum value and the charging current starts to decrease. This means that the base current drops, with a resulting drop in collector current. The drop in collector current reverses the polarity of the voltage induced in the secondary winding of T_1 .

If the base-emitter of the transistor were a bilateral conductor, this reversal of signal polarity across the secondary of T_1 would simply result in the rapid discharge of C_1 . However, since the base-emitter passes current in only one direction (that is, acts like a diode), C_1 cannot discharge over its charging path and must, instead, discharge through R_1 and R_2 .

The result is a sudden pulse of current flow as C_1 charges rapidly, with a comparatively long period of virtually no current flow as C_1 discharges slowly through R_1 and R_2 . The charging time depends on the value of C_1 and upon the combined impedances of the base-emitter circuit of the transistor and the secondary winding of T_1 . The discharge time depends on the value of C_1 and upon the values of R_1 and R_2 , that is, upon the resulting RC time constant of these components.

Once C_1 has discharged sufficiently to permit the start of base current flow again (over a path consisting of the battery, B_1 , R_1 , R_2 , and the base-emitter of the transistor), the charging cycle is repeated.

This action then continues, with the pulses repeated at intervals determined primarily by the RC time constant (R_1 , R_2 , C_1) and by the battery voltage, and with each pulse giving a "plop" of fairly good volume in the loudspeaker. Adjusting R_2 permits the repetition rate ("beats" per minute, or frequency) to be varied.

Since appreciable current flow occurs only during the short time interval of the pulses, the average current drain from the battery is small, and battery life is long, even though a small "hearing aid" type battery is employed. The average current drain will depend, however, upon the number of "beats" per minute, with high repetition rates requiring considerably more power.

A stepdown turns-ratio is used in the transformer (T_1) to match the

high impedance of the collector circuit to the low input impedance of the base-emitter circuit. A still greater stepdown ratio (taps on the secondary winding) is used to match the even lower impedance of the loudspeaker voice coil.

A toggle switch, S_1 , is provided to turn the unit "on" and "off."

Construction Hints

The entire "Transistor Metronome" has been assembled in a commercially available 3" meter case, with the small loudspeaker mounted behind the meter opening. Plastic grille "cloth" was used by the author to cover the speaker opening, but this may be left uncovered, if desired, or plain screening or flock-covered screening used instead.

In assembling the unit, a small aluminum chassis was used to mount the transformer, battery, transistor, and condenser (C_1), with the control (R_2) and power switch (S_1) mounted on the cabinet.

The location of all major components except the transistor itself is clearly visible in the interior view of the unit, Fig. 1. Note that the condenser (C_1) is mounted below the chassis. The transistor is mounted on a terminal strip directly behind the small battery.

When installing the transistor, the author simply soldered the unit in place. Another builder might prefer to use a socket, however. A small 5-pin subminiature tube socket is suitable, with only 3 of the pins being needed.

Should the builder decide to follow the author's example and wire the transistor into the circuit, he should exercise special care when soldering the connections. Transistors are easily damaged by excessive heat. Each connection should be made as quickly as possible, using a very hot, clean, well-tinned iron. The transistor leads should not be cut short.

A small "Z" bracket was used to hold the battery in place. The author found that small size paper clips made almost perfect connection clips for the battery, slipping over the projecting terminals. However, if the builder prefers, battery connections may be made by soldering the leads directly to the brass battery terminals. Care should be taken not to overheat the battery if this technique is used.

Parts Substitutions

A number of parts substitutions are possible, depending on the needs and requirements of the individual builder. For example, a larger speaker and different case might well be employed (a larger speaker will provide somewhat greater volume). A wall speaker baffle makes an excellent cabinet where a wooden case is preferred.

A type CK721 transistor may be substituted for the type CK722 used by the author, with no changes in connections or circuit values. (Both are "p-n-p" junction transistors.)

The prospective builder may prefer to use a different battery in place of the 15-volt hearing aid type battery used by the author. The circuit is not at all critical and will operate with comparatively low voltages, although the operating frequency as well as the output amplitude (volume) may change. Other suggested batteries are the Mallory 302424 (a 6.7 volt battery designed specifically for transistor applications), the Eveready type 411 (another 15 volt battery), and the RCA type VSO68 (a 6.3 volt "A" battery).

Any standard "universal" audio output transformer should give satisfactory results, although the builder may have to experiment somewhat with the tapped secondary connections. The terminal connections and color-coding given in the schematic diagram (Fig. 2) refer specifically to the Stancor unit.

A slide or rotary switch might be used in place of the toggle switch employed in the author's model, or, if preferred, a control type switch on R_2 may be used as a power switch. This move would reduce the number of controls from two to one.

Substitutions for C_1 , R_1 , and R_2 will depend on the operation desired.

Circuit Modifications

A fairly wide range of "beat" signals is provided by the component values given in the parts list. In the author's model, the range is from 1 beat for every 7 seconds to about 20 beats-per-second. This is a far wider range than is needed for musical applications only—a range of from 1 beat-per-second to 5 per-second should be satisfactory for most musical requirements (60 to 300 beats-per-minute).

Where the builder has a specific application in mind, he will find it quite easy to choose parts values giving the desired repetition rates and range coverage. Different values of C_1 , R_1 , and R_2 may be used to give almost any range desired.

The fixed resistor, R_1 , is chosen to

give a particular maximum (or minimum) repetition rate for specific values of C_1 and R_2 .

All three component values may vary with different transistors and supply voltages, and hence it is difficult to determine these components in advance. Rather, the circuit is built up and an easily available value chosen for C_1 (50, 100, 150, 200, or 250 μ f.). This condenser is connected into the circuit, and a resistance substitution box used in place of R_1 and R_2 .

The resistance is then adjusted until the desired *minimum* repetition rate is obtained. This value is the total value of R_1 and R_2 , and may be termed R_t .

Next, the resistance is varied until the desired *maximum* repetition rate is obtained. This value is equal to R_1 .

R_2 is a potentiometer having a standard value most closely approaching the difference of the two values determined experimentally, that is, $R_2 = R_t - R_1$.

Where the value of R_2 does not even closely approach a commercially available potentiometer, a different value of C_1 may be used.

If several ranges are desired, a selector switch may be provided to insert different values of C_1 into the circuit.

Another circuit modification is to dispense with a continuously adjustable control entirely and to provide a selector switch inserting fixed values of C_1 and R_1 . In this way, two, three or more fixed beat rates may be provided (depending on the number of switch positions available).

Still another circuit modification is to provide earphone, rather than loudspeaker, output. Simply connect a pair of low-impedance magnetic earphones in place of the loudspeaker voice coil.

Calibration

No effort was made by the author to accurately calibrate the settings of R_2 in terms of "beats"-per-second (or per-minute), since this was not necessary in the application in which the author's model was used.

However, for many applications a calibrated control will be desirable.

Several techniques may be used for calibrating the completed instrument, depending on the repetition rate and the accuracy desired. First, however, a scale and a pointer knob should be provided for the control. For maximum accuracy, a large scale is desirable, and it may be found best to mount the control on the side of the meter case, where greater panel space is available.

For low repetition rates and an approximate calibration, an ordinary stop-watch may be employed, the operator "counting" between beats (or between seconds at higher rates).

Where a more accurate calibration is desired, the builder may borrow another metronome (either a mechanical or electronic model) that is accurate.

(Continued on page 158)

Fig. 2. Complete schematic of the metronome which uses one "p-n-p" transistor.

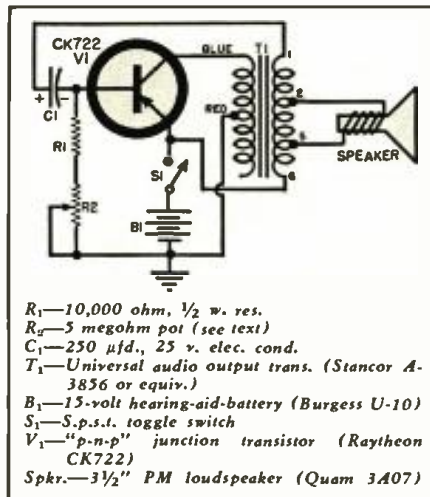

80-METER NOVICE TRANSMITTER

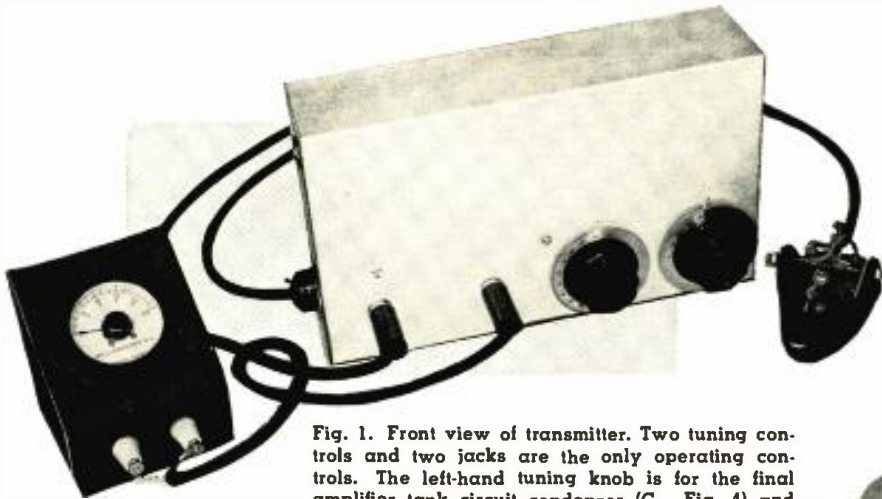

Fig. 1. Front view of transmitter. Two tuning controls and two jacks are the only operating controls. The left-hand tuning knob is for the final amplifier tank circuit condenser (C_{10} , Fig. 4) and the right-hand control is for antenna loading condenser (C_{11} , Fig. 4). The left-hand jack connects to key while right-hand jack is for insertion of a plate current meter. This 75 ma. d.c. meter is not part of the circuit.

By

DAVID D. BULKLEY and MERRITT F. KIRCHHOFF
W2QUJ W2FAR

A compact, easy-to-build rig for Novices. Standard and readily-available parts are used throughout.

A NOVICE transmitter is more than an assemblage of simple, straightforward circuits employing readily available components. There is many a slip 'tween the cup and the lip in the design and construction of a transmitter suitable for the newcomer to the amateur ranks.

Therefore, a Novice transmitter is offered here which has been designed with the Novice in mind from start to finish. First, circuits have been chosen which are simple yet efficient. Second, the mechanical layout has taken into consideration the wiring procedure; the photographs show that although quite compact, every part is easily accessible and no trouble should be experienced in soldering every part into place. Third, the tubes and parts are inexpensive standard items, readily obtainable from any amateur supply house.

However, one point before we begin; no matter how carefully a trans-

Fig. 2. The power supply is constructed on a separate chassis.

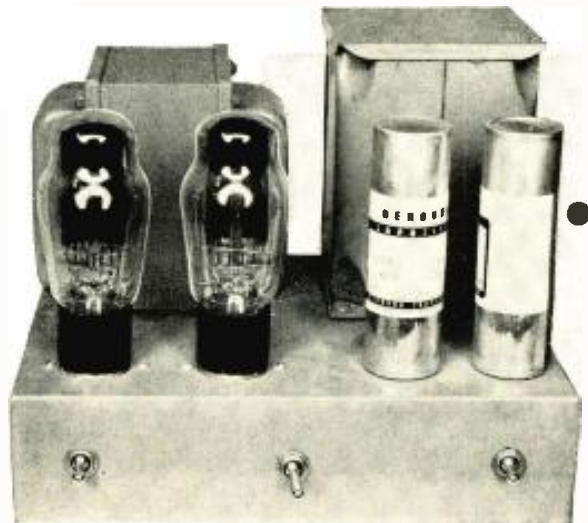

mitter is designed and no matter how much energy has been put into building it, it is all to no avail if the instructions and parts list are not carefully followed. Therefore, the Novice is urged to follow the text faithfully and to use only the components specified in the parts list.

Electrically, the transmitter consists of three tubes in two stages. Ample output is obtained in the 80-meter band with the full legal limit of 75 watts of power input. Only two tuning controls are required which makes tuning operations more simple and foolproof than ever.

The circuit consists of a modified Pierce crystal oscillator employing one type 6V6 tube. The Pierce type of oscillator requires no tuning control; it operates merely by inserting the proper crystal and applying the re-

quired voltages. However, the Pierce requires that "fundamental" type crystals be used. Fundamental crystals are ground to the fundamental frequency at which they are to oscillate while "harmonic" type crystals oscillate at a higher frequency than that to which they are ground.

The crystal oscillator is capacity-coupled to the r.f. amplifier stage. The use of capacity coupling eliminates the necessity of one tuning control and simplifies operation. The r.f. amplifier stage consists of two type 6AU5 tubes connected in parallel (that is, the elements of one tube are connected to the corresponding elements of the other). Parallel operation provides twice the r.f. output power obtainable from one tube.

The plate circuit of the r.f. amplifier is connected in a simple, combination final amplifier tank and antenna tuning circuit. This circuit consists of a pi-type network which permits tuning the r.f. amplifier to proper resonance and also permits loading the amplifier circuit to the antenna at the same time. The use of the pi-type network also permits the transmitter to be loaded to an antenna of any convenient length. Yes, whether a short or long antenna is used it will load up properly with this antenna tuner circuit to give optimum output.

The front of the transmitter (Fig. 1) presents a neat, clean appearance with only two tuning controls and two jacks. The left-hand tuning control is for the final amplifier tank circuit

Fig. 3. Underchassis view of transmitter showing the correct parts layout.

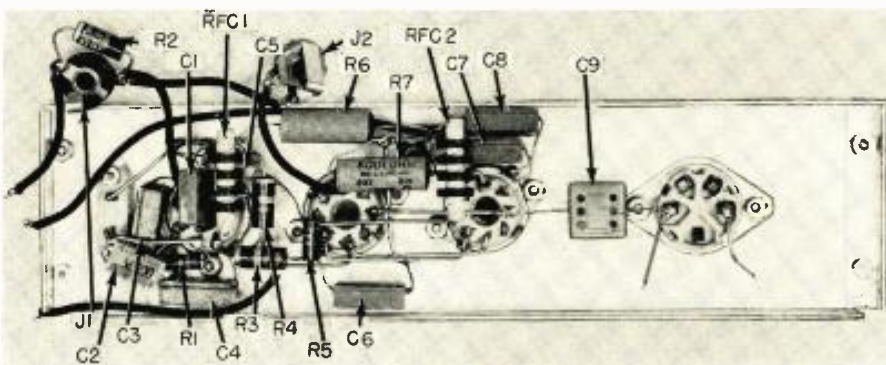

condenser (C_{10}) and the right-hand tuning control is for the antenna loading condenser (C_{11}). The left-hand jack connects to the key while the right-hand jack is for insertion of a plate current meter used while tuning the transmitter. After tuning operations are completed, the meter plug may be removed.

The transmitter case consists of an inexpensive aluminum chassis 12" x 7" x 3". This type of mounting not only eliminates the need for a front panel but also provides shielding for unwanted radiation. The transmitter will be virtually harmonic-tight if a light aluminum grill is placed on the back of the transmitter.

Inside the aluminum chassis is mounted a simple aluminum shelf or sub-chassis on which all tubes and components are mounted. The use of this little sub-chassis permits 90 percent of the wiring of the transmitter to be accomplished with ease; all parts, etc. are mounted on the little shelf and the shelf is fixed in position inside the chassis. Then with the connection of the few wires to the jacks and the condensers the job is done.

The rear view of the transmitter (Fig. 5) illustrates the logical and neat layout that is offered in this transmitter. On the top of the small sub-chassis on the right hand side is seen the crystal. Next, to the left, is found the 6V6 crystal oscillator tube followed by the two 6AU5 r.f. tubes. Finally on the far left may be seen the r.f. amplifier/antenna tuner coil, a standard commercial unit.

Beneath the small sub-chassis may be seen, on the far right, the power connector, a flush mounted male type unit to insure that accidental contact is not made with the power plug. To the left of this are some of the small components. The two tuning condensers for the r.f. amplifier are found next. On the extreme left a coaxial cable connector is mounted on the end of the chassis. Although this type of connector is suggested, any convenient type of insulated antenna terminal may be substituted. The use of the coaxial receptacle permits a TVI filter to be easily attached should this be required.

Fig. 2 shows the power supply. Conservatively rated, this unit insures troublefree operation. The plate and filament transformer is located in the rear left of the chassis, while the filter choke is on the right rear of the chassis. The filter condensers are mounted on the right front corner of the chassis. The two rectifier tubes are seen in the left front corner of the chassis. Referring to the circuit diagram (Fig. 4) it will be seen that two rectifier tubes are used in parallel. This is because the maximum amount of current that one 5U4G tube will handle is 250 milliamperes. Although this is adequate for operation within the legal input permitted Novices, a sufficient margin of safety is desirable for possible overload during tuning

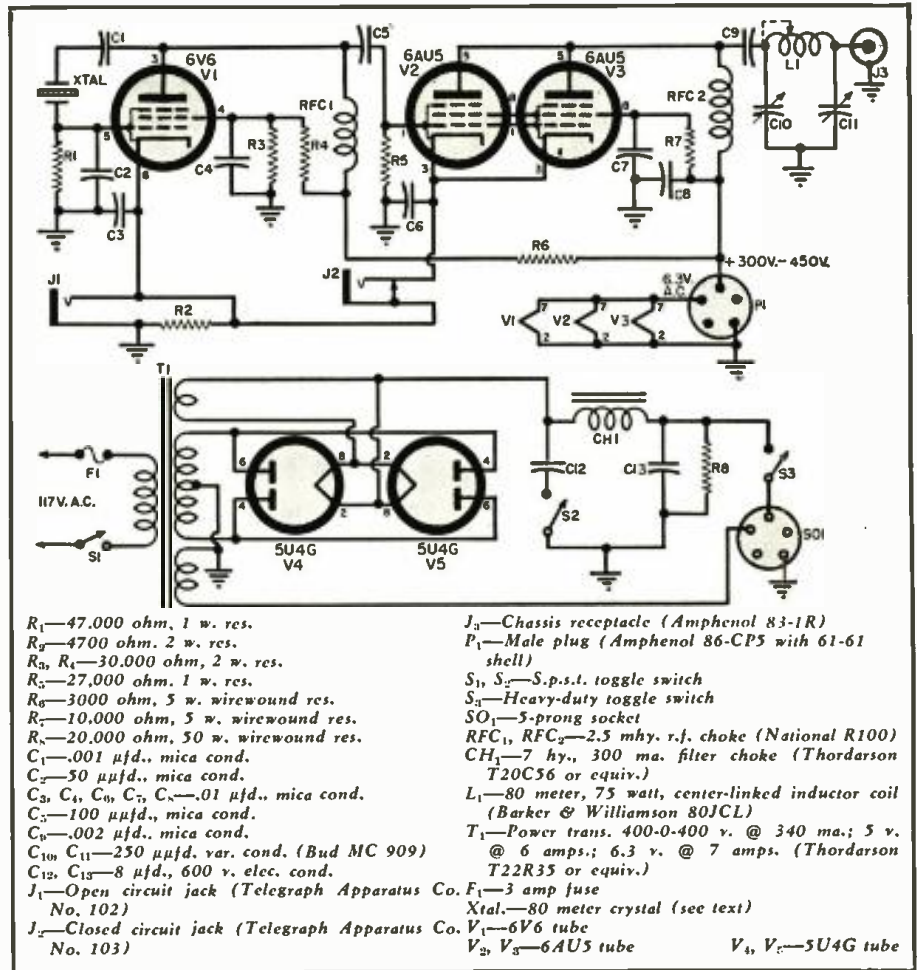

Fig. 4. Complete schematic of transmitter and its associated power supply. Note the turns shorting jumper on coil, L_1 , shown dotted. As mentioned in the text, short turns of the coil only if proper antenna loading is not obtained.

up operations, etc. The left hand toggle switch, S_1 , controls the primary of the power transformer (T_1), the middle toggle switch, S_2 , reduces the power supply voltage 100 volts for use when testing and for tuning operations. This is accomplished by removing the input electrolytic conden-

ser C_{12} from the filter circuit for reduced voltage. The right-hand toggle switch, S_3 , controls the plate voltage.

Fig. 3 indicates the arrangement for mounting all sockets and for soldering the components in place.

The small sub-assembly chassis is (Continued on page 150)

Fig. 5. Rear view of transmitter showing the sub-chassis type of construction. The B & W coil, L_1 , shown on the left is supplied with an antenna coupling loop. This may be ignored in this particular circuit as it is not needed in this application.

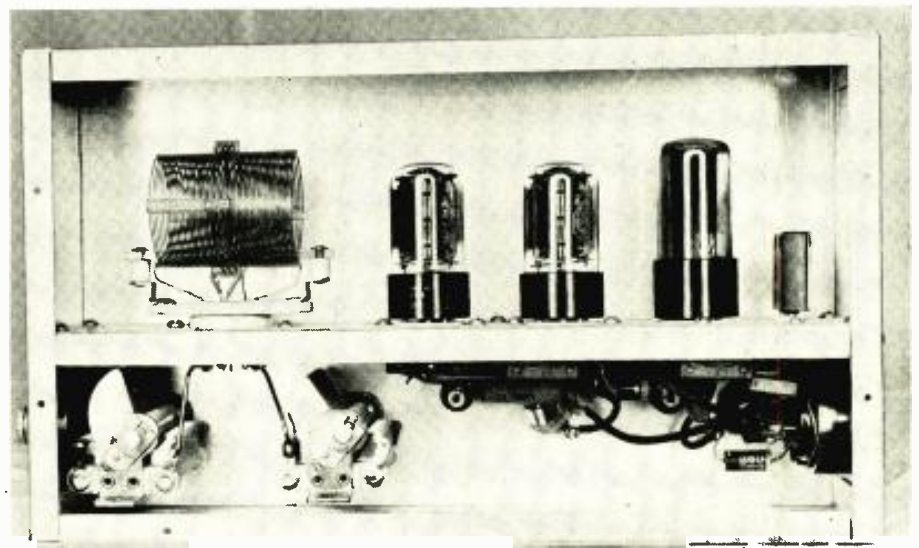
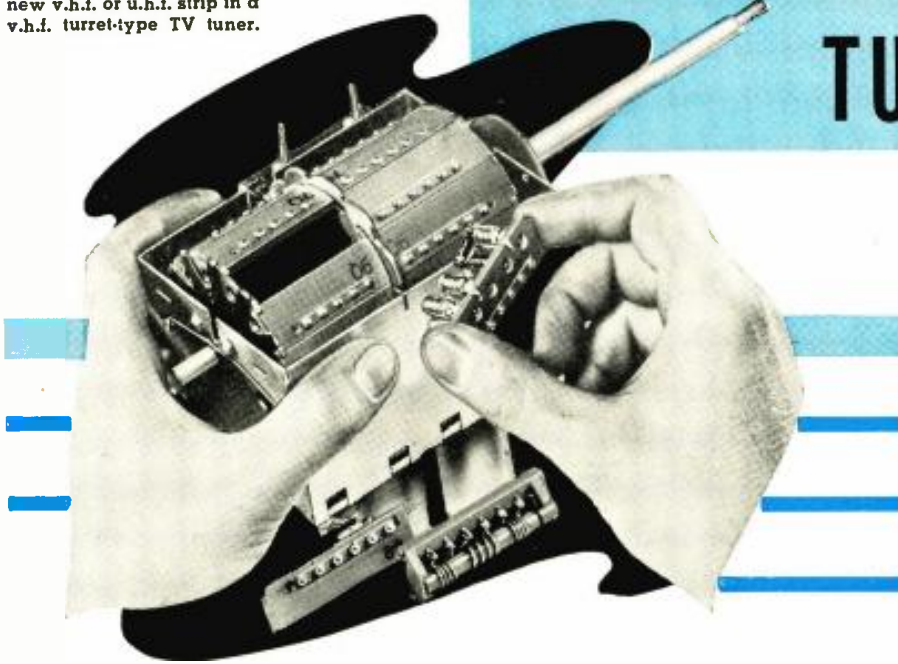

Fig. 1. Replacing a defective v.h.f. coil strip with a new v.h.f. or u.h.f. strip in a v.h.f. turret-type TV tuner.



TROUBLESHOOTING THE TURRET TUNER

By **MILTON H. LOWE**
Coastal Publications

Most new TV sets use the cascode amplifier turret tuner for v.h.f. Here is up-to-date data for faster servicing.

ALTHOUGH much has been said and written about v.h.f. front ends, much has been left unsaid. It is the purpose of this article to bring you up-to-date on the latest v.h.f. tuners and their servicing problems.

A careful survey of the tuners being used in most recent TV receivers reveals that the turret type which uses a cascode r.f. amplifier is most popular. One of the reasons for its popularity lies in the ease with which such a tuner may be made to receive u.h.f. signals; *i.e.*, since all twelve v.h.f. channels are never allocated in any one area, the unused strips in the turret can be removed and replaced with u.h.f. tuning strips. Fig. 1 shows how easily a u.h.f. tuning strip can be inserted into a turret tuner.

Another reason for the popularity of this type tuner hinges on the performance of the cascode circuit, which minimizes the reception problem in fringe and other low-signal areas. Turret tuners that contain a conventional pentode r.f. amplifier are also in use, but inasmuch as their circuitry is relatively familiar, they will not be discussed.

A partial schematic diagram of the cascode circuit used in *Emerson, Zenith, Admiral, Du Mont, Olympic*, and other current receivers, is shown in Fig. 3. The 6BZ7 (the 6BK7 and 6BQ7 are often used) twin triode used for the r.f. amplifiers is designed to have a low-noise figure. The circuit shown provides a maximum signal-to-noise output from the r.f. amplifiers. (The noise referred to is the noise gen-

erated within the r.f. stages and not the noise riding on the input signal. All circuit elements generate noise which is sometimes visible as snow on the picture tube. This noise is due to the random movement of electrons, and also to variations in cathode emission, leakage currents, and other causes. Obviously, a low-noise tuner must contain low-noise generating circuits.)

The input signal is applied from the antenna terminals, through the parallel resonant traps comprised of L_1-C_6 and L_2-C_7 , to the antenna coil in the turret strip. The traps attenuate all signals in the frequency range from 40 to 47 mc., and thus minimize the possibility of unwanted signals (in this range) passing through the tuner to the 40 mc. i.f. strip. An additional i.f. trap consisting of L_6 and C_1 is series-resonant at 40 mc., and provides a low-impedance shunt to ground, which further attenuates these undesired signals.

The signal developed across the antenna coil is stepped up so as to increase the signal level with respect to the noise generated within the tube. This is accomplished by making the impedance of the first r.f. amplifier higher than the impedance of the transmission line, thus obtaining a voltage gain. The balanced input circuit is designed to match a 300-ohm transmission line to the grid circuit of the first r.f. amplifier. Resistor R_2 loads the input circuit and lowers its "Q" and thereby increases its bandwidth to pass the 6 mc. wide TV channel.

On the higher channels, the transit time of the electrons (*i.e.*, the period of time required for the electrons to flow from the cathode of a tube to the plate) is an appreciable portion of the cycle of the operating frequency, and a change in the grid or plate potentials may not affect the plate current instantaneously. The transit time is less than one-thousandth of a millionth of a second (.001 μ sec.), a number which may seem insignificant, but which represents an appreciable part of a cycle at 174 mc. (channel 7) and higher frequencies. This transit time causes an undesirable phase shift that can be thought of as an inductive lag in the grid circuit. It causes the grid to absorb power even though it may be negatively biased. This is brought about by the currents which are induced in the grid by the exchange of energy between the grid signal voltage and the electrons traveling to the plate. The power loss can be thought of as being caused by a resistor (load) that shunts the grid and cathode electrodes. This loading must be compensated for if adequate signal is to be developed in the grid-cathode circuit of the first r.f. amplifier. As a matter of fact, if the grid circuit isn't compensated by a voltage that "replaces" the absorbed power, a virtual short may exist between the grid and cathode at very high frequencies.

The procedure by which a voltage is fed back from one point to another to cancel an undesirable effect is termed neutralization. Condenser C_9 is the neutralizing condenser that feeds back a voltage from the plate to the grid-cathode circuit, thus minimizing the loading due to transit time. Condenser C_2 is made variable to provide for variations in circuit components, aging, etc.

The first r.f. amplifier is a conventional grounded-cathode stage whose gain is controlled solely by the a.g.c. The second r.f. stage is a driven grounded-grid amplifier, whose grid is maintained at r.f. ground by C_{10} , which provides a virtual short at the signal frequency. The output of the first r.f. stage is developed across inductor L_7 and is injected into the cath-

ode circuit of the second r.f. amplifier. A fixed potential of approximately 120 volts is applied from the junction of voltage divider resistors R_3 and R_4 to the grid through isolating resistor R_5 .

The potential at the cathode is approximately 120 volts also. This is due to the fact that the two r.f. stages are in series insofar as the "B+" supply is concerned, and they act like voltage dividers splitting the "B+" potential between them. The bias measured from grid to cathode is thus approximately zero volts.

The d.c. voltages that can be expected in circuits of this type vary from about 110 to 150 volts, but the bias in each case will be near zero. In some receivers the bias may be as high as -3 volts. Voltage divider bias is used in preference to contact potential because it minimizes the effects due to variations in tube characteristics.

An interesting feature of the cascode circuit is the manner in which the a.g.c. potential controls the gain of both r.f. stages even though it is applied directly only to the first stage. Assume that the input signal increases. Then, the a.g.c. potential becomes more negative, thus increasing the bias on the first r.f. amplifier. This causes the plate current to decrease, which results in an increased dynamic plate resistance that causes the plate 1 potential to increase. Now, since cathode 8 and plate 1 are at the same d.c. level, the cathode 8 voltage is also increased. Since the grid 7 voltage is fixed, the net effect is to increase the bias on the second r.f. amplifier. This reduces the gain of the second stage, tending to keep the driving voltage applied to the mixer constant for small variations in overall signal strength. Condenser C_5 is provided to adjust the response of the plate circuit.

The output of the second r.f. amplifier is inductively coupled to the mixer grid circuit. The output of the local oscillator (a modified Colpitts in which C_{21} and C_{22} are the split tank condensers, and the combination of R_{12} and C_{22} provides the signal bias) is injected into the mixer cathode circuit by virtue of the fact that the local oscillator and mixer use the common cathode of the 6J6 (pin 7). A portion of the mixer output voltage is fed back through C_{21} and L_{12} to neutralize the mixer grid circuit. If this were not done, the mixer might break into oscillation at the intermediate frequency. Inductor L_{13} and condenser C_{22} in series with it, comprise a low-pass filter network that attenuates signals above the intermediate frequencies, and thus prevents them from entering the i.f. strip. The combination of R_{11} and C_{23} decouples the mixer plate circuit from the "B+" supply.

The most striking aspects of the cascode circuit, insofar as d.c. measurements are concerned, are the potentials at the cathode and grid of the second r.f. amplifier. As mentioned previously, these potentials are ap-

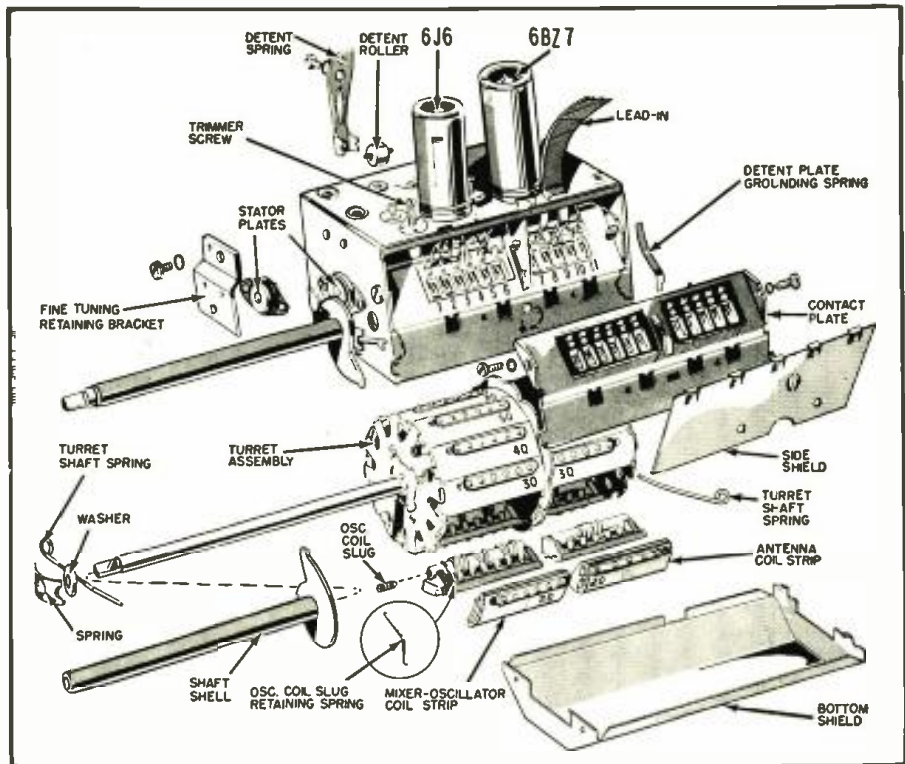
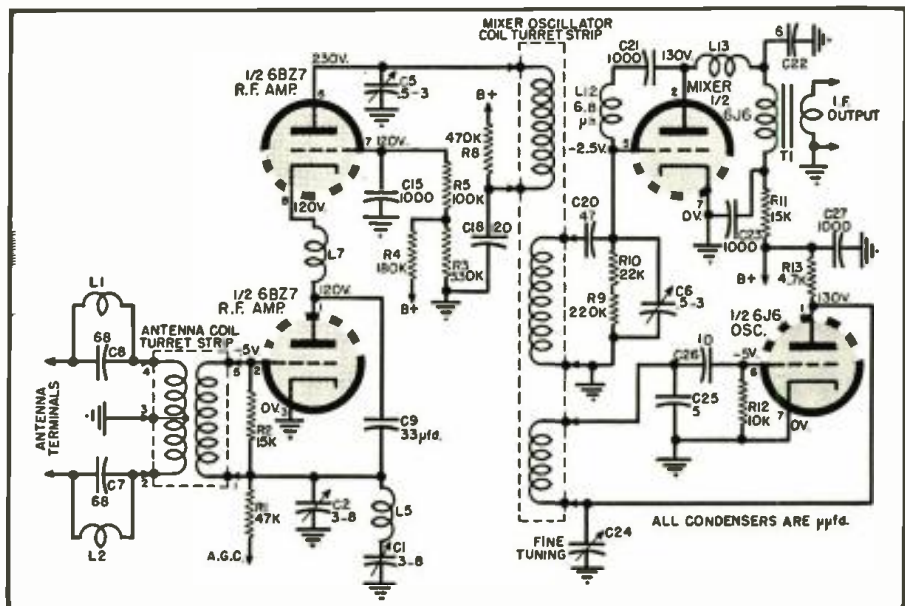

Fig. 2. Exploded view of a v.h.f. turret tuner, useful as a guide for disassembly.

proximately 120 volts with respect to ground. This fact must always be borne in mind for two reasons, the first being that this unusually high voltage (for grid-cathode circuits of TV receivers) is the normal state of the circuit. The second, a little more important from a practical standpoint, is that care must be taken to set the voltmeter for at least the 150-volt range when making measurements at these points. Normally, the meter is set on the 10-volt range when measuring cathode potentials, and in this circuit this could lead to a damaged meter if it isn't capable of handling the overload.

From a troubleshooting standpoint, the tuner is the most unique section of the TV receiver, for here is the only electromechanical device of real significance. It is the only device in the receiver that you must be capable of repairing, not only electrically, but also mechanically. Fig. 2 is an exploded view of a typical turret tuner. Each movable part is a potential source of trouble that usually manifests itself as microphonics. The principal sources of these physical troubles are: dirt or corroded contacts on the antenna and mixer-oscillator coil assemblies, broken or bent contact springs, loose oscillator coil tuning slugs, de-

Fig. 3. Partial schematic diagram of a cascode amplifier, v.h.f. turret tuner of the type used by Emerson, Admiral, and others in their new TV receivers.



STAGE	PIN NO.	NORMAL READINGS		POSSIBLE CAUSE OF ABNORMAL READINGS
		Voltage	Resistance	
R.F. Amp. 1	1	zero	inf.	C ₀ shorted
	2	-2.7	2 megohms	R ₁ or R ₂ open, charred
	3	zero	zero	Cold solder joint, broken lead
R.F. Amp. 2	6	215	18,000 ohms	C ₁ or C ₁₅ shorted, R ₁ open, r.f. coil open
	7	140	260,000 ohms	R ₁ , R ₁₁ , or R ₃ open, C ₁₅ shorted
	8	zero	inf.	C ₀ shorted
Mixer	2	130	30,000 ohms	L ₁₃ open, C ₂₁ , C ₂₂ , or C ₂₃ shorted, R ₁₁ open
	5	zero	240,000 ohms	R ₀ or R ₁₀ open, C ₀ or C ₂₀ shorted
	7	zero	zero	Cold solder joint, broken lead
Oscillator	1	130	20,000 ohms	R ₁₃ open, C ₂₇ , C ₂₁ or C ₂₃ shorted
	6	zero	10,000 ohms	C ₂₀ shorted, R ₁₂ open

Table 1. Static troubleshooting chart for the circuit shown in Fig. 3.

fective detent assemblies, and miscellaneous broken parts. Also important is the possibility of cold solder joints, broken socket pins, and poor tension of the contact springs.

Simple procedures like cleaning the tuner contacts or adjusting the tension of the springs, are readily performed as follows: First, remove the bottom shield and several of the coil strips. Then, rotate the turret to permit access to the contacts through the opening thus provided. To clean the contacts, use a brush or soft cloth moistened with carbon tetrachloride, "No Noise," or similar preparations. To adjust the spring tension, use a screwdriver to bend each contact slightly. To check the tension of the contacts, place the turret in a position between channels, and check the clearance between the contact springs and the flat surface of the coil strip. The clearance should be about $\frac{1}{16}$ " or the thickness of a playing card.

To completely disassemble the tuner, remove parts in this order: the

bottom shield, side shield, detent plate grounding spring, contact plate (first unsoldering the parts connected to its lugs and tagging each one so as to facilitate its replacement), fine tuning retaining bracket, outside stator plate, shaft shell, spring, washer, front turret shaft spring, rear turret shaft spring, and the detent spring and roller. Then, cant the turret assembly to remove it from the tuner housing. Once this is done, the electrical components are completely accessible, and the replacement of a tube socket, resistor, condenser, etc., becomes a much simpler job than if attempted with only the side shield removed. Obviously, all parts and leads should be replaced and dressed exactly as in the original, if "bugs" are to be avoided. Also, all leads should be kept as short as possible.

There are two methods by which it is possible to check the circuits in the tuner. The first is a static method that is the more direct of the two. Its main advantage lies in the fact that

the tuner does not have to be partially disassembled to gain access to the tube sockets and components. The procedure is as follows: remove the tubes from their sockets, one at a time, and take measurements from the top of the tube socket rather than from the tube pins. A word of caution is necessary—do not force or wiggle the test leads excessively in the socket as this may spread the contacts and lead to future erratic operation. Also, remember that the pins are read counterclockwise from the top of the socket.

Table 1 is a static troubleshooting chart that is directly applicable to the circuit shown in Fig. 3. It is generally applicable to other cascode circuits, with variations of ± 20 per-cent. These particular voltage measurements were taken with the antenna disconnected, antenna terminals shorted, controls set for a normal picture, and a 3-volt negative bias applied to the a.g.c. bus. Tubes should be checked first, of course.

The second method, that of taking dynamic measurements at the socket pins with the stages in regular operation, requires that the side shield be removed to gain access to the bottom of the tube socket. When taking measurements, care must be taken not to push aside parts and wiring, because the dress of leads and the placement of parts may be critical. Typical dynamic measurements are shown in Fig. 3. A point to remember is this. If the second r.f. amplifier is defective, there may be no plate voltage available for the first r.f. amplifier. In some receivers, the sound output tube also functions as a voltage divider, and a lack of "B+" voltage for the tuner can be traced to a defective audio output tube.

Table 2 contains a partial list of receiver symptoms that may be caused by defective components in the tuner. Obviously, many of these symptoms may arise from defects in other parts of the receiver circuit. It is recommended, therefore, that realignment of the tuner or extensive tuner repairs be delayed until other troublesome circuits have been checked thoroughly.

Before readjusting the oscillator slug for optimum performance, remember to set the tuning control to the center of its range. The oscillator slug may fall into the coil if it is turned too far, requiring the removal of the coil strip to salvage the slug. Where feedthrough or disc-type ceramic condensers are replaced, care should be taken not to apply excessive pressure or heat to the new condenser, since this will cause the silver-plated surface to fracture or peel. A soldering gun or pencil-type soldering iron has been found ideal for work in and around the tuner.

Many of the techniques for troubleshooting the v.h.f. turret tuner are applicable also to the servicing of the 82-channel u.h.f.-v.h.f. tuner described in the September, 1953 issue of RADIO & TELEVISION NEWS.

Table 2. Partial list of receiver symptoms caused by defective tuner.

SYMPTOM	POSSIBLE CAUSE OF TROUBLE
Improper tuning	Oscillator slug misadjusted, fine tuning control not centered mechanically.
Distorted sound	Same as above.
Audible or visual microphonics	Mechanical modulation of local oscillator due to binding knobs or shafts; loose tube shield, poor mechanical or solder joints, etc.
Sound bars in picture	Fine tuning off, oscillator slug misadjusted, microphonic tubes.
Snow* and weak sound	Antenna connections, antenna, second r.f. amplifier not neutralized properly.
Poor fringe reception	R.F. amplifiers defective
Transients in picture	Tuner requires alignment**

*A quick check that can be used to determine whether the snow is due to a defective tuner, or due to outside sources is as follows: Disconnect the antenna, short the antenna terminals, and turn the contrast control all the way up. If excessive snow appears, the noise is generated within the receiver.

**The specific technique for aligning the front end varies from receiver to receiver, and requires test equipment with crystal accuracy. For this reason, the author recommends that alignment be undertaken only by those possessing adequate test equipment, and then only when the manufacturer's specific instructions are followed.

TV STATIONS ON THE AIR

Complete list of all television stations in operation as of November 25th, 1953. There are now 112 u.h.f. and 212 v.h.f. stations on the air in the continental United States. This list also includes stations in Alaska, Hawaii, Canada, and Mexican border stations.

CITY, STATE	CALL	CHANNEL	CITY, STATE	CALL	CHANNEL	CITY, STATE	CALL	CHANNEL
ALABAMA			IDAHO			Duluth	WFTV	38
Birmingham	WABT	13	Boise	KIDO-TV	7	Minneapolis-St. Paul	KSTP-TV	5
Birmingham	WBRC-TV	6	Meridian	KBOI-TV	2	Minneapolis-St. Paul	WCCO-TV	4
Mobile	WALA-TV	10	Nampa	KFXD-TV	6	Minneapolis-St. Paul	WMIN-TV	11
Mobile	WKAB-TV	48	Pocatello	KWIK-TV	10	Minneapolis-St. Paul	WTCN-TV	11
Montgomery	WCOV-TV	20				Rochester	KROC-TV	10
ARIZONA			ILLINOIS			MISSISSIPPI		
Mesa	KTYL-TV	12	Belleville	WTVI	54	Jackson	WJTV	25
Phoenix	KOOL-TV	10	Champaign	WCIA	3	Meridian	WTOK-TV	11
Phoenix	KOY-TV	10	Chicago	WBMM-TV	2	MISSOURI		
Phoenix	KPHO-TV	5	Chicago	WBKB	7	Hannibal	KHOA-TV	7
Tucson	KOPO-TV	13	Chicago	WGN-TV	9	Kansas City	KCMO-TV	5
Tucson	KVOA-TV	4	Chicago	WNBO	5	Kansas City	KCTY	25
Yuma	KIVA	11	Decatur	WTVP	17	Kansas City	KMBC-TV	9
ARKANSAS			Peoria	WEEK-TV	43	Kansas City	WDAF-TV	4
Fort Smith	KFSA-TV	22	Peoria	WTVH-TV	19	Kansas City	WHB-TV	9
Little Rock	KRTV	17	Quincy	WVEM-TV	10	Kansas City	KFEQ-TV	2
CALIFORNIA			Rockford	WREX-TV	13	St. Joseph	KSD-TV	5
Bakersfield	KAFY-TV	29	Rockford	WTVO	39	St. Louis	KSTM-TV	36
Bakersfield	KERO	10	Rock Island	WHBF-TV	4	Springfield	KTTS-TV	10
Chico	KHSL-TV	12	Springfield	WICS	20	Springfield	KYTT	3
Eureka	KIEM-TV	3	INDIANA			MONTANA		
Fresno	KJEO	47	Bloomington	WTTV	10	Billings	KOOK-TV	2
Fresno	KMJ-TV	24	Evansville	WFIE	62	Butte	KOPR-TV	4
Los Angeles	KECA-TV	7	Fort Wayne	WKJG-TV	33	Butte	KXLF-TV	6
Los Angeles	KHJ-TV	9	Indianapolis	WFWM-TV	6	NEBRASKA		
Los Angeles	KLAC-TV	13	Lafayette	WFAM-TV	59	Lincoln	KFOR-TV	10
Los Angeles	KNBH	4	Muncie	WLBC-TV	49	Lincoln	KOLN-TV	12
Los Angeles	KNXT	2	South Bend	WSBT-TV	34	Omaha	KMTV	3
Los Angeles	KTLA	5	IOWA			Omaha	WOW-TV	6
Los Angeles	KTTV	11	Ames	WOI-TV	5	NEVADA		
Los Angeles	KUSC-TV	28	Cedar Rapids	KCRI-TV	9	Las Vegas	KLAS-TV	8
Monterey	KMBY-TV	8	Cedar Rapids	WMT-TV	2	Reno	KZTV	8
Sacramento	KCCC-TV	40	Davenport	WOC-TV	5	NEW JERSEY		
Salinas	KSBW-TV	8	Des Moines	KGTV	17	Atlantic City	WFPG-TV	46
San Bernardino	KITO-TV	18	Fort Dodge	KQTV	21	Newark	WATV	13
San Diego	KFMB-TV	8	Sioux City	KVTV	9	NEW MEXICO		
San Diego	KFSD-TV	10	KANSAS			Albuquerque	KGGM-TV	13
San Francisco	KBAY-TV	20	Hutchinson	KTVH	12	Albuquerque	KOAT-TV	7
San Francisco	KGO-TV	7	Topeka	WIBW-TV	13	Albuquerque	KOB-TV	4
San Francisco	KPIX	5	Wichita	KEDD	16	Roswell	KSWB-TV	8
San Francisco	KRON-TV	4	KENTUCKY			NEW YORK		
San Luis Obispo	KVEC-TV	6	Henderson	WEHT	50	Albany	WROW-TV	41
Santa Barbara	KEYT-TV	3	Louisville	WAVE-TV	3	Binghamton	WNBF-TV	12
Tulare-Fresno	KCOK-TV	27	Louisville	WHAS-TV	11	Buffalo	WBNB-TV	4
COLORADO			Louisville	WKLO-TV	21	Buffalo	WBES-TV	59
Colorado Springs	KKTV	11	LOUISIANA			Buffalo	WBUF-TV	17
Colorado Springs	KRDO-TV	13	Baton Rouge	WAFB-TV	28	Buffalo	WECT-TV	18
Denver	KBTU	9	Lake Charles	KTAG-TV	25	Elmira	WTVL	24
Denver	KFEL-TV	2	Monroe	KFAZ	43	Elmira	WABE-TV	7
Denver	KLZ-TV	7	Monroe	KNOE-TV	8	New York	WABC-TV	7
Pueblo	KCSI-TV	5	New Orleans	WDSU-TV	6	New York	WABD	5
Pueblo	KDZA-TV	3	New Orleans	WJMR-TV	61	New York	WCBS-TV	2
CONNECTICUT			MAINE			New York	WNBT	4
Bridgeport	WICC-TV	43	Bangor	WABI-TV	5	New York	WOR-TV	9
New Britain	WKNB-TV	30	Portland	WPMT	53	New York	WPIX	11
New Haven	WNHC-TV	6	MARYLAND			Rochester	WHAM-TV	6
Waterbury	WATR-TV	53	Baltimore	WAAM	13	Rochester	WHCT-TV	10
DELAWARE			Baltimore	WBAL-TV	11	Rochester	WVET-TV	10
Wilmington	WDEL-TV	12	Baltimore	WMAR-TV	2	Schenectady	WRGB	4
DISTRICT OF COLUMBIA			MASSACHUSETTS			Syracuse	WHEN	8
Washington	WMAL-TV	7	Boston	WBZ-TV	4	Syracuse	WSYR-TV	3
Washington	WNBW	4	Boston	WNAC-TV	7	Utica	WKTU	13
Washington	WTOP-TV	9	Boston	WTAO-TV	56	NORTH CAROLINA		
Washington	WTTG	5	Cambridge	WHYN-TV	55	Asheville	WISE-TV	62
FLORIDA			Holyoke	WWLP	61	Charlotte	WAYS-TV	36
Fort Lauderdale	WFTL-TV	23	Springfield	WWOR-TV	14	Charlotte	WBTV	3
Jacksonville	WMBR-TV	4	MICHIGAN			Greensboro	WFMY-TV	2
Miami	WTVJ	4	Ann Arbor	WPAG-TV	20	Greenville	WNCN-TV	9
Panama City	WJDM-TV	7	Battle Creek	WBCK-TV	58	Raleigh	WNAO-TV	28
Pensacola	WEAR-TV	3	Battle Creek	WBKZ-TV	64	Winston-Salem	WSIS-TV	12
Pensacola	WPFA-TV	15	Cadillac	WWTU	13	Winston-Salem	WTOB-TV	26
St. Petersburg	WSUN-TV	38	Detroit	WJTB-TV	2	NORTH DAKOTA		
West Palm Beach	WIRK-TV	21	Detroit	WWJ-TV	4	Fargo	WDAY-TV	6
GEORGIA			Detroit	WXYZ-TV	7	Minot	KCBT-TV	13
Atlanta	WAGA-TV	5	Flint	WTAC-TV	16	OHIO		
Atlanta	WLWA	8	Grand Rapids	WOOD-TV	7	Akron	WAKR-TV	49
Atlanta	WSB-TV	2	Kalamazoo	WKZO-TV	3	Ashtabula	WICA-TV	15
Augusta	WJBF-TV	6	Lansing	WILS-TV	54	Cincinnati	WCPO-TV	9
Columbus	WDAK-TV	28	Lansing	WJIM-TV	6	Cincinnati	WKRC-TV	12
Columbus	WRBL-TV	4	Saginaw	WKNX-TV	57	Cincinnati	WLWT	5
Macon	WETV	47	MINNESOTA			Cleveland	WEWS	5
Macon	WMAZ-TV	13	Austin	KMMT	6	<i>(Continued on page 162)</i>		
Rome	WROM-TV	9						

THE KARLSON SPEAKER ENCLOSURE

By

JOHN E. KARLSON

Karlson Associates

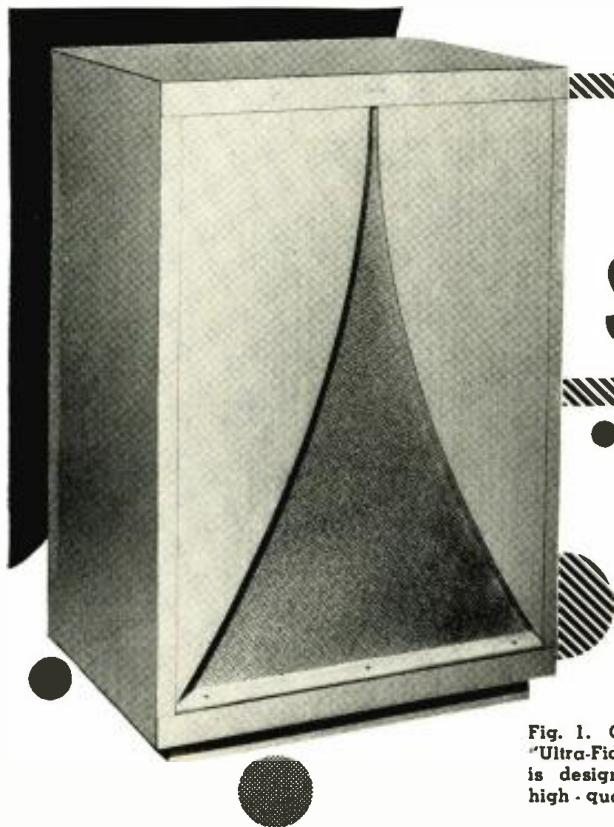

Fig. 1. Over-all view of the Karlson "Ultra-Fidelity" model enclosure. It is designed specifically to house a high-quality 15-inch loudspeaker.

Construction and engineering details on an enclosure for 15-inch speakers which incorporates acoustical coupling to provide improved transient response, good definition.

THE Karlson "Ultra-Fidelity" enclosure has been designed to fill the need for a loudspeaker system whose performance would be at least comparable to that of the other components in a high-quality music system.

In order to bring this worthy motive out of the realm of the fantastic and into the pale of practical accomplishment, some extremely knotty problems had to be licked. These included the design of an acoustic coupler capable of providing a flat response over the frequency range from 20 to 20,000 cycles, an omnidirectional radiation pattern over the same range, accurate tonal phasing, and nearly optimum transient response. Of course,

this unit should also fit into the average sized living room.

In reviewing all of the available approaches to this problem it became clear that none of the existing techniques were adequate in meeting these difficult requirements. For example, horns could provide good coupling down to these frequencies if they were big enough, but even if the size could be tolerated, the frequency range could not be covered by a single horn. When the higher frequencies are radiated from horns, an increased directive beaming effect is experienced which distorts the relative tonal values of the reproduced material. This effect can be reduced by using several horns, but when this is done, accurate

phasing for all of the frequency components in any musical sound becomes virtually impossible. When direct radiators are substituted for horns in the higher frequency ranges, phasing difficulties must result due to the widely differing acoustic paths of the high and low frequencies. In addition, the transient responses of horns and direct radiators are noticeably different.

In continuing this analysis it became increasingly obvious that some new acoustic device was needed which could meet these requirements. As a result the exponential coupler was brought into existence. Fortunately, the inherent characteristics of this type of coupler are almost ideal for our requirements in that it has:

- (a) A flat frequency response over a desired range
- (b) Extremely uniform dispersion of sound at all frequencies when properly designed
- (c) Excellent transient response
- (d) Potentialities for point-source phasing

Probably the least obvious advantage in the list is that of point-source phasing. However, when we consider that only a point source of sound provides absolutely uniform dispersion and phasing at all frequencies, the importance of this feature becomes a little more obvious. Strangely enough,

Fig. 2. Impedance characteristics of test speaker measured without any enclosure.

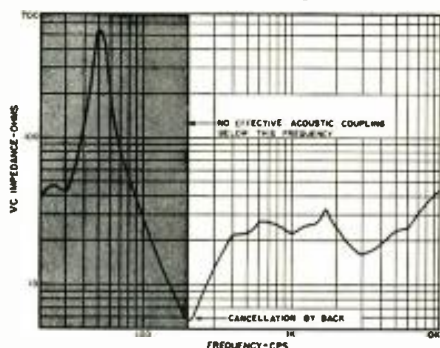

Fig. 3. Same speaker in 2700 cu. ft. infinite baffle radiating into a free field.

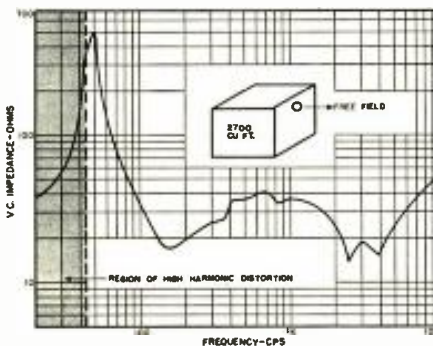
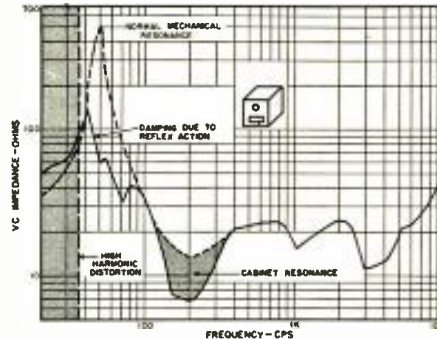

Fig. 4. Same test speaker in a commercial model 6 cu. ft. bass reflex cabinet.



if a radiator does not have uniform dispersion of its sound, the effect will be to pinpoint the location of the speaker due to its more directive beam pattern. This phenomenon has often been erroneously called the "point-source effect" whereas it is actually due to a relatively large directive radiator.

Design Considerations

In evolving the final design for this enclosure, it was obvious that the end result had to look attractive enough for use in even the most affluent homes. Therefore considerable effort was expended in creating a model which had an optimum aspect ratio, suitability to any decor, maximum utility, and adaptability to almost all cone-type speakers.

When these factors were decided, perfection of the internal design was begun. The speaker was provided with both front and back loading for optimum coupling. Ordinarily front loading presents difficulties due to the natural resonances of almost any

structure used. However, the exponential coupler solved this problem and the speaker was matched to this coupler in the manner shown in Fig. 5. With this careful matching of the relative coupler and speaker impedances, the size of the speaker is virtually expanded to that of the air in the tapered aperture which is capable of tremendous excursion without distortion. When the front and back loading is properly phased and balanced through the use of the port and matching shelf between the front and rear chambers, the speaker becomes capable of extraordinary intensities of sound without distortion. Even at the extreme low frequencies the output is predominantly fundamental with usually less than 2% distortion at 30 cycles when used with a good speaker. The solid construction of the cabinet also prevents any bellowing or vibration of the cabinet at these frequencies.

The graphs of Figs. 2, 3, 4, 6, 7, 8, 9, and 10 indicate the reasons for the

performance obtained. A highly efficient speaker was used in a series of tests conducted to give positive evidence of the characteristics of this enclosure. Consequently the relative impedance values are high. A 1:1 impedance ratio bridge was used to measure the impedances. The damping indicated in this enclosure is due to the loading of the air (radiation resistance) rather than heavily absorbent materials. This feature is relatively unique in the field because the broadband impedance matching required for this type of air loading has usually only been available through the use of very large exponential horns. Electrical impedance curves may be readily flattened out by employing "lossy" devices such as heavy padding and constricted openings. However, the result achieved is somewhat equivalent to putting the speaker in a pile of pillows. This technique will yield very flat impedance curves, but no sound. With proper air coupling, all of the energy in the speaker

Fig. 5. Complete mechanical details on the Karlson "Ultra-Fidelity" enclosure. A 12-inch speaker can be used by either using a separate conversion board or cutting the speaker opening smaller. This particular cabinet was designed for use with a coaxial type speaker. If a single speaker is used, it should be of the extended-range type.

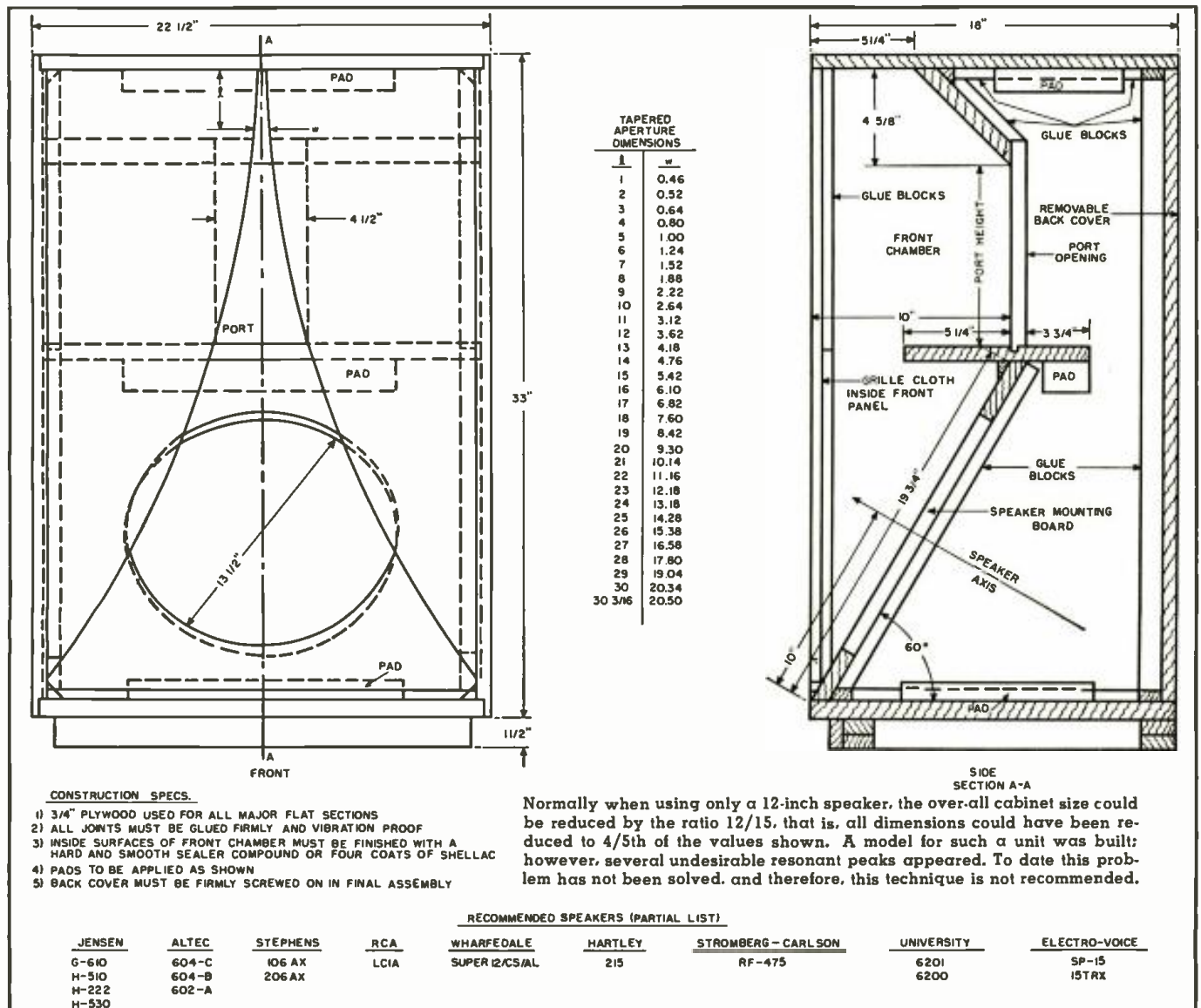

Normally when using only a 12-inch speaker, the over-all cabinet size could be reduced by the ratio 12/15, that is, all dimensions could have been reduced to 4/5th of the values shown. A model for such a unit was built; however, several undesirable resonant peaks appeared. To date this problem has not been solved, and therefore, this technique is not recommended.

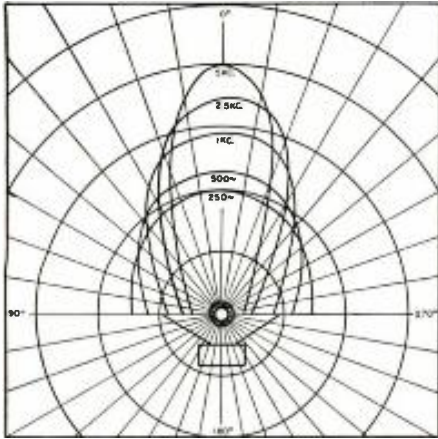

Fig. 6. Relative responses with constant acoustic output for 15" direct-radiator. Side lobes are omitted to simplify graph.

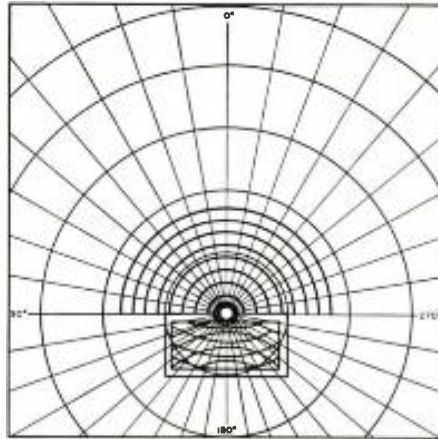

Fig. 7. Uniform dispersion characteristics of radiation from a slot. Very little variation occurs with changes of frequency.

is dissipated in the room rather than in the enclosure.

Transient Response

In addition to the greater efficiency derived from the close coupling, a decided improvement in the transient response is achieved, enabling the detection of even the weakest sounds in a musical passage. This feature, when combined with accurate phasing for all frequencies, provides an extremely fine definition of all complex passages of music, so that even in the heaviest orchestral attacks the separate parts may be clearly distinguished. The importance of transient response in electronic music systems cannot be over-emphasized, inasmuch as all natural sounds are composed primarily of transients. Perhaps the simplest test for transient response is that of listening to white noise at high levels. White noise is most readily obtained by adjusting the FM tuner to a position between stations so that the strong hiss is obtained. This hiss usually contains frequency components in the entire audio spectrum. When a loudspeaker system contains any peaks or dips in its response, these will be apparent in a critical listening test. The high frequency peaks will be characterized by a singing predominant tone while low frequency peaks will be characterized by a blow torch effect. The over-all response of a system in comparison with another can also be checked by this method with differences in the high, low, and mid-

dle ranges quite readily apparent. With two flat systems of equal high-frequency responses, the one having the lower frequency range will appear to drop the over-all tonal quality by some appreciable factor.

Distortion

A good deal of the distortion found in reproduced sound can also be reduced or eliminated through the use of strong front and rear speaker coupling. Ordinarily, speaker cones are subject to a wide variety of resonant frequencies inherent to the structure of the cone. If a speaker cone were to be examined under a stroboscope, it would be seen that the cone vibrates in several different modes other than the simple forward and backward motion. When a heavy transient attack occurs, the cone is likely to vibrate at any or all of its resonant frequencies with the result that considerable harmonic distortion is likely to occur. Also, when a cone is subjected to large excursions which take it beyond its limits of linear travel, intermodulation effects occur which generate a whole series of sum and difference frequencies. The net result is likely to be somewhat fuzzy. Now, with heavy damping on both the front and back of the speaker cone, these spurious oscillations are largely damped out or eliminated. Also, due to the heavier loading, the cone requires less travel for the same acoustic output with the result that excursions in the non-linear region of the cone travel

are unnecessary for even the loudest level of operation. Loading only one side of a cone cannot possibly achieve the same results because full control of the cone doesn't exist over the complete cycle of its travel.

Coupling Performance

A series of tests was conducted, as previously indicated, to establish the characteristics of the coupling achieved in the "Ultra-Fidelity" enclosure. The most sensitive indication was considered to be that of taking a series of electrical impedance curves to indicate the differences resulting from mounting the speaker in various forms of enclosures. A curve was first taken of a speaker lying on a bench without any enclosure or baffle board attached. The results of this test are shown in Fig. 2. It will be observed that cut-off occurs in the region of 200 cycles, but that the general slope of the mechanical resonance peak, occurring at 50 cycles, is virtually identical to that found in Fig. 3, which shows a corresponding curve with the speaker mounted in an extremely large infinite baffle radiating into a free field. Apparently there is virtually no difference in the coupling achieved by the infinite baffle type of mounting, and therefore its primary advantage is that of isolating the frontwave from the backwave of the speaker. Naturally any sound occurring in a region of 50 cycles in an infinite baffle of this size would send the speaker cone into a prolonged oscillation. Even when the speaker has this extended travel, it doesn't necessarily produce a considerably greater output at this single frequency because the vibration of the cone alone is inadequate for producing a proportionate amount of acoustic power. In other words, without auxiliary coupling to the air, a cone will simply beat the air ineffectively at the very low frequencies. Some improvement in this mechanical resonance curve is shown by the use of a bass reflex cabinet tuned to anti-resonance at the same frequency. See Fig. 4. Also, the radiation from the port in the neighborhood of this frequency will increase the efficiency of the speaker output in this general range. However, below this resonant frequency, harmonic distortion increases

(Continued on page 108)

Fig. 8. Impedance curve in Karlson enclosure showing its non-resonant character.

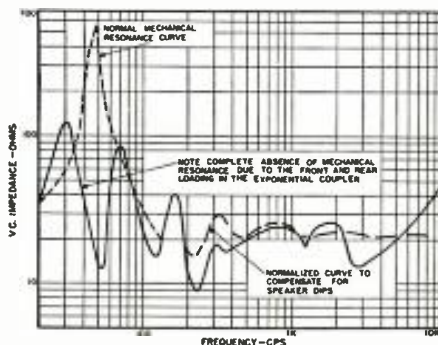

Fig. 9. Impedance curve of matched non-resonant transformer. See text for discussion.

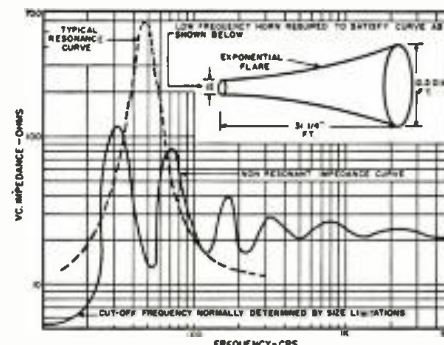
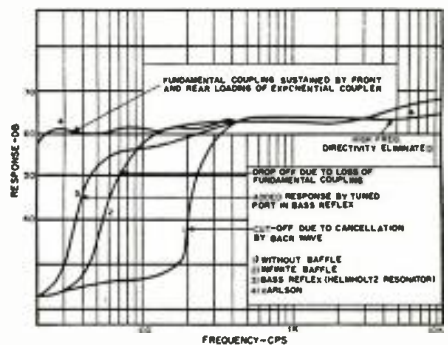

Fig. 10. Frequency response curves of Karlson compared with other standard approaches.





THE CONVAIR ANALOGUE COMPUTER

By
R. D. HORWITZ

Electronics Engineer
Engineering and Electronics Laboratories
Consolidated Vultee Aircraft Corp.

Fig. 1. The "Convair" analogue computer in operation. Two problem patchboard stations in normal operating position are shown in one-half section of the dual computer console. In the foreground the engineer checks mobile recorder unit which draws graphs that are the solutions to the problems on the computer. The resistance and capacitance decade boxes are shown at top.

This million-dollar unit can be set up to obey the flight equations of an airplane, computing motions of aircraft in flight.

TODAY is the age of computers. A slide rule, an adding machine, or even a man making a left turn onto a crowded highway is a computer. Anything that involves the weighing of related factors and seeking a solution of an unknown related to these factors can be considered a computer. The concern of this article is with analogue computers rather than digital computers.

One of the first questions asked when a visitor, not familiar with computers, is shown the *Convair* computer is: "What is the difference between an analogue and a digital computer?"

Analogue computers use continuously variable quantities such as voltages or shaft rotations to represent numbers. Digital computers use discrete quantities such as pulses to represent numbers and compute by counting. One kind of analogue computer is an electrical model of the mechanical system one wishes to study. Currents and voltages in the computer correspond

to forces and displacements in the mechanical system. *Convair's* electronic analogue computer is of a different type: it uses voltages and shaft rotations that obey the same mathematical equations that govern the physical system under study. This computer can be set up to obey the flight equations of an airplane, computing the motions of the aircraft in flight.

"This is nice," says our visitor, "but let us get to something simple. Add two and two." Coming from an analogue computer, the answer would most likely be, 3.999 or 4.001. Such a computer is not an exact device, but one that approximates correctness depending on the accuracy of both the operator and the components in the computer.

"All right, then, what do you put in and where does it come out?" asks the visitor. To answer this question, it is necessary to start with the language of the computer.

The components of the computer

have block diagrams that identify their functions and serve as guideposts for the operator when he sets up a problem. See Fig. 2. Fig. 2A is the symbol for an amplifier. Usually the amplifier is shown with its input and feedback resistances (Fig. 2B). It is the ratio of the values of these resistances that determines the gain of the amplifier.

Since all voltages are referred to ground, the ground terminals are usually not shown. The basic amplifier can do many things, (a) It can add and when so doing is called a "summing amplifier" or "summer," Fig. 2C. (b) It can perform integration, Fig. 2D, and is called an "integrator." (c) With the aid of a potentiometer, it can multiply by a constant (Fig. 2E). For this case the potentiometer is adjusted so that it will divide any voltage such as x by 2. The amplifier is adjusted for a gain of ten. (d) An amplifier in conjunction with a servo-controlled motor, Fig. 2F, which drives

(Continued on page 130)

Fig. 2. Steps in setting up a problem for the analogue computer to solve. See text for details on each individual operation.

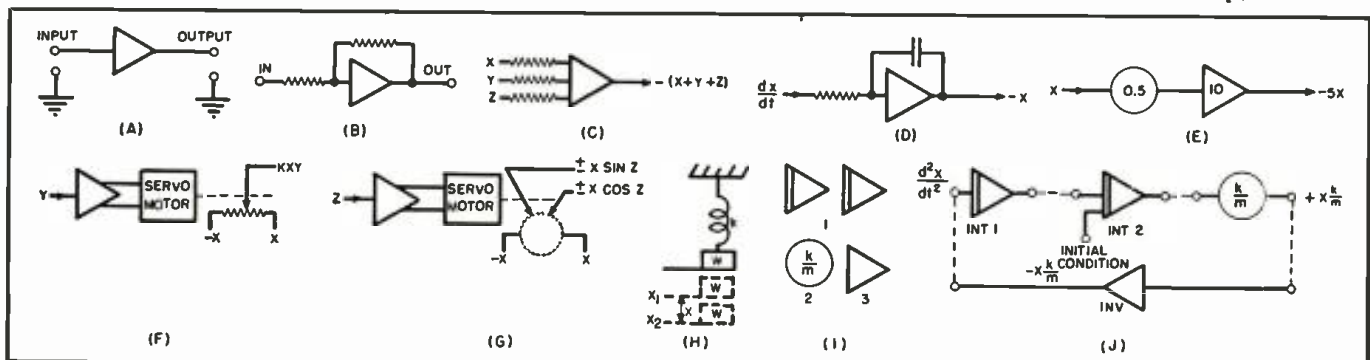

A Dual Channel

By OLIVER READ *

RECORDING SYSTEM

Part 3. Concluding article covers interconnection of the three racks and operation of the relay controls.

AS MENTIONED in previous installments of this series, the major components comprising tuners, preamplifiers, and power amplifiers may be preset so that line voltage may be controlled to any combinations of principal units by means of a master switch. Reference to Fig. 2 shows, in simplified form, the relay control circuitry. Note that the contacts of the relays are not shown. These relays are designed for 6-volt d.c. operation, and the normally-open contacts are single-pole, single-throw. The control panel is located directly beneath the binaural tape recorder (Fig. 1), and includes a

master (heavy duty) toggle switch and eight s.p.s.t. toggles for excitation of the various components. 6-volt pilot lamps serve to indicate active circuits.

The 6-volt d.c. supply is a *Heath "A"* battery eliminator and is of the dry disc type. In addition to supplying the necessary current to the relay coils, it also supplies 6 volts to the indicator lamps of the vu meters for illumination. It is good engineering practice, wherever possible, to utilize direct current for meter lamps—and this was

* Editor and Assistant Publisher, RADIO & TELEVISION NEWS and RADIO-ELECTRONIC ENGINEERING.

done in this design. The pilot lamps on the relay control panel are all 6 volts, with the exception of the indicator lamp above the master switch—the latter being designed for a 120-volt miniature lamp.

Line voltage to the 6-volt d.c. supply is controlled by the master switch. In shunt with this circuit is the elapsed time meter. The total operating hours are recorded on the meter.

Relay *RY₁₄*, which controls the line amplifier, is controlled by the master switch. This component is one which is commonly in use at all times, either for recording or for playback.

The other relays are controlled from the relay panel as shown. In practice, a particular combination of tuners, preamplifiers, monitor amplifiers, and power amplifiers is set up on the control board, and these are then con-

Fig. 1. Front view of the three rack assemblies. All of the system's individual components are clearly identified.

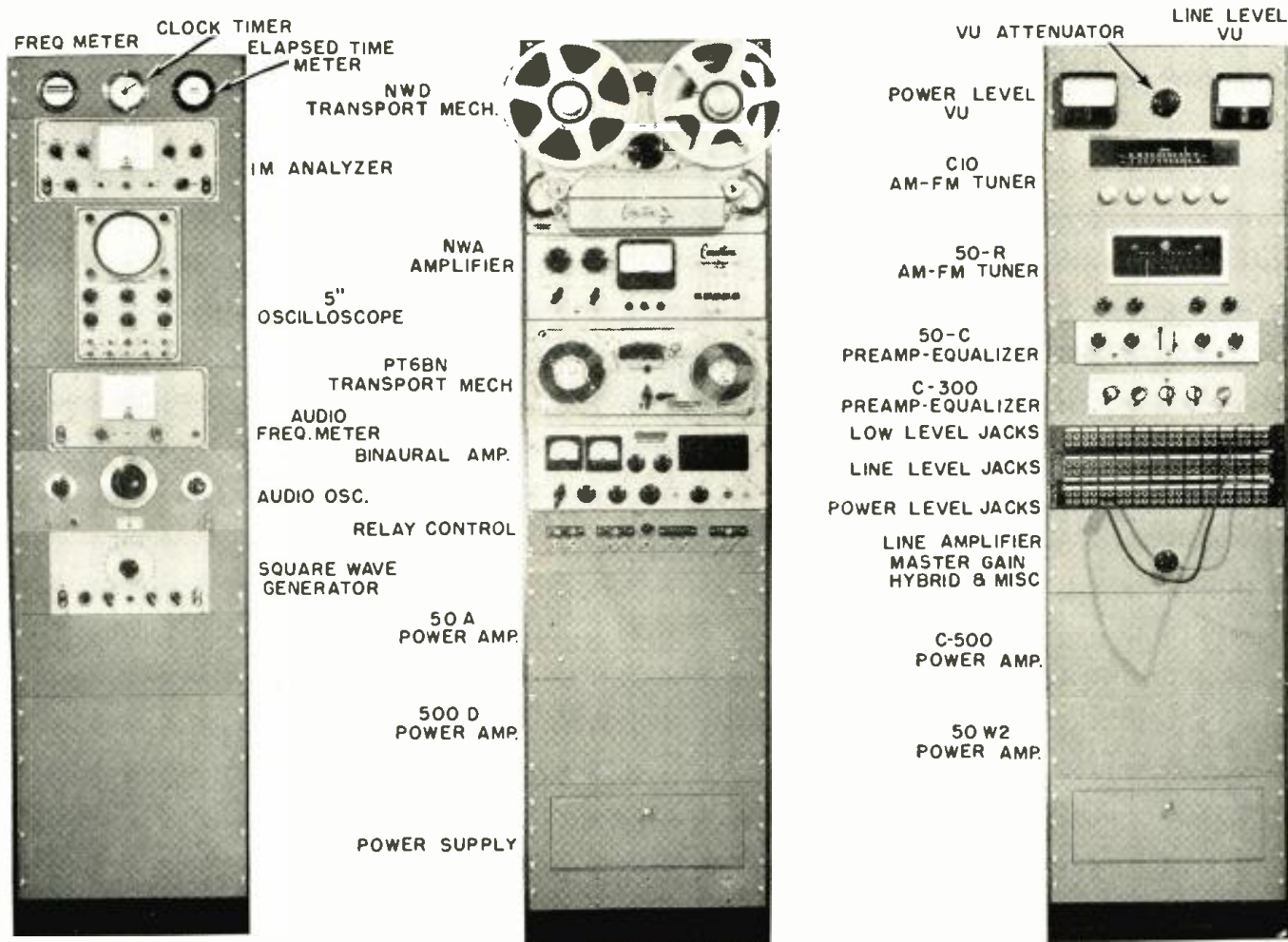

trolled entirely by means of the master switch. All of the individual component "on-off" switches are kept in their "on" positions. The only exceptions in this system are the two tape recorders and the various test equipment contained in rack No. 3.

The particular indicator lamps shown were aircraft-surplus components which possessed compactness and pleasing appearance. Normally, the assembly included three separate indicator lamps. In this particular installation, the two outside circuits were used, and the center section used to include the spare lamps.

All of the system's components are identified in Fig. 1. Their applications have been described fully in previous articles, with the exception of rack No. 3.

A convenient means was desired for having readily accessible test gear on hand for various measurements of the system. The components mounted on rack No. 3 comprise the following: a *Frahm* frequency meter, *Sessions* timer clock, *J-B-T* elapsed time meter, *Heath* intermodulation analyzer, *Heath* 5-inch oscilloscope, *Heath* audio-frequency meter, *Hewlett-Packard* audio oscillator, and a *Heath* square-wave generator.

These particular units lend themselves to rack mounting simply by providing large cutouts on the relay-rack

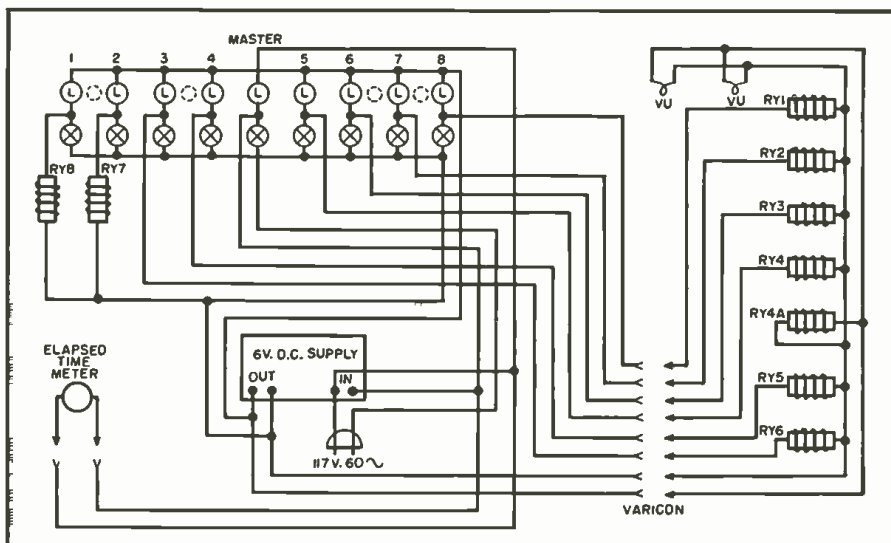

Fig. 2. Control circuit relays are 6 volt d.c. units with s.p.s.t. normally open contacts.

panels, which are dimensioned slightly under the panel dimensions provided for the instrument.

Oversized self-tapping screws extend from the instrument panel through oversized holes in the rack panel and engage the metal boxes housing the instrument.

While these components do not necessarily represent a complete test setup, it should be mentioned that they

are augmented by various other audio test equipment, either too small for rack mounting, or because they may be used more conveniently as separate units.

The three racks comprising the system (Fig. 3) have been separated in order to properly identify the components. In order to complete the installation, it is only necessary to provide
(Continued on page 163)

Fig. 3. All that is necessary to complete the installation is to wire in inter-rack cables as described in text.

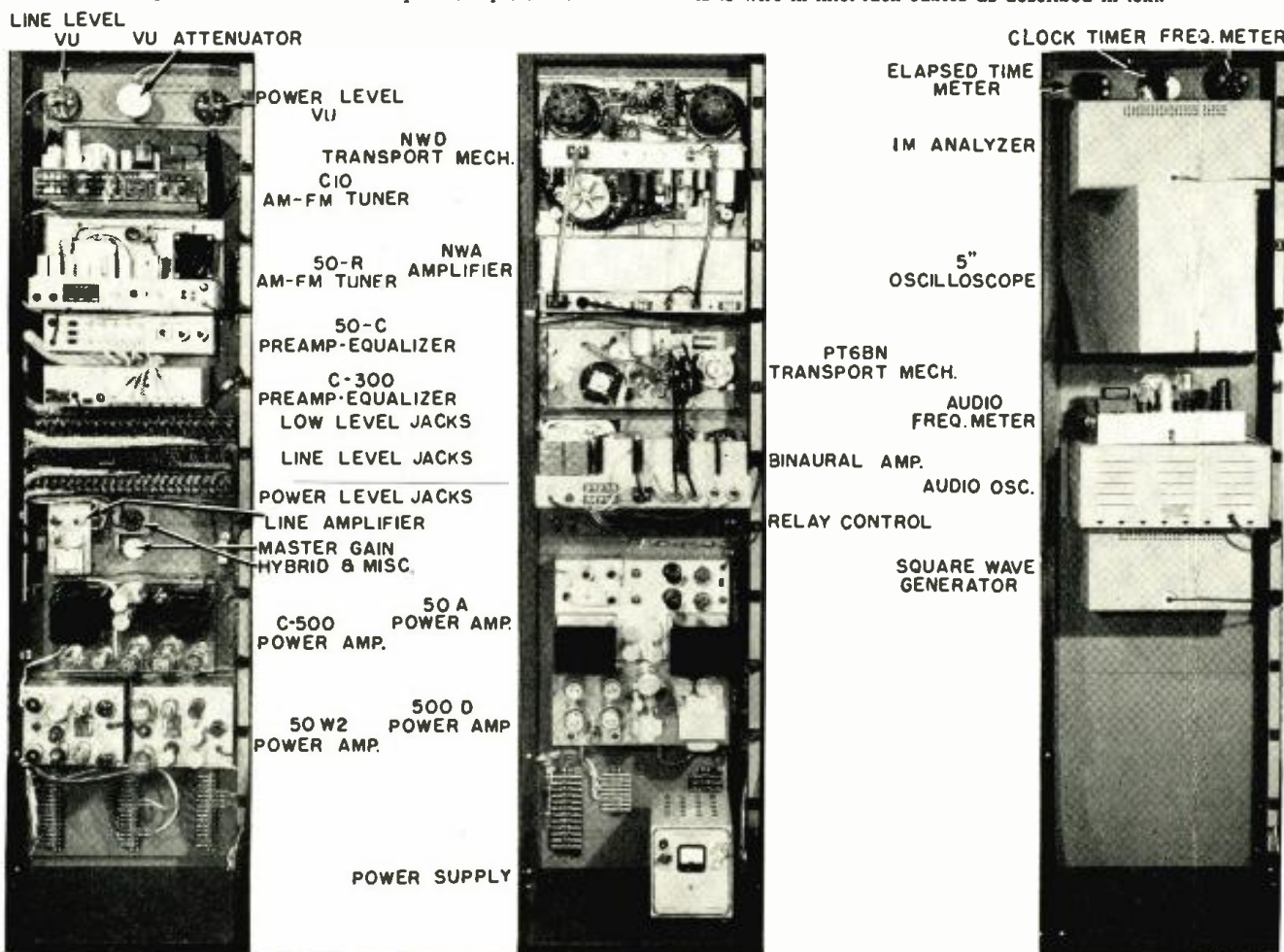



Certified RECORD REVUE

By **BERT WHYTE**

I SUPPOSE a good many people read this column each month and say to themselves, "this guy Whyte sure has a lot to gripe about." They are referring of course to the remarks I make in the preface to the review section. It seems I am always finding fault with any number of things in the world of audio. Now believe me, I'm not trying to be any tub-thumping hi-fi evangelist. I don't feel that my mission on earth is to root out audio evils, and to castigate and damn the perpetrators of these evils. However, I do feel that as long as these pages are open to my use, I have a certain obligation to you, the reader. The least I can do is to draw your attention to those malpractices which may be detrimental to your ultimate listening pleasure. And now for my latest "gripe."

The New York Audio Fair was the subject of a post-mortem discussion with some friends the other day. Most of the people in the group were *professionals* in the field of audio, the rest of the group best described as "advanced enthusiasts." Out of the welter of subjects we talked about, *pro* and *con*, there were several points upon which there was unanimous agreement. These points are going to shock you! One, with few exceptions, everyone agreed that there was really *nothing basically new* at the Fair; and two, the *reproduction heard in most rooms was disgraceful!* No, I'm not kidding. And I might add that I have heard this same opinion expressed by many others outside of this group whereof I speak. Do you know they are absolutely right! Of all places in the world, you would certainly expect to hear the finest in sound at an Audio Fair. Here is where the manufacturers are supposed to put their best foot forward. Here is the culmination of much time and effort in audio design and research. Alas, the results this year were hard to believe. The sound in most rooms was just impossible. Distortion was ever present, harsh strident highs were matched by incredible boom and "juke box" bass. Now here is the strange thing about all this; the *equipment* was only partially to blame. There was a personnel factor involved which was equally

guilty. As you know, high fidelity has been coming along for a long time, and it wasn't so many years ago that some friend would rush up to us very much excited and tell us about his new tweeter that was good out to 7 or 8000 cycles! Yes, for a long time it was the highs that counted and everyone expended much effort in trying to achieve higher and higher frequency range. Today there are many good tweeters and speakers on the market that go out as far as the human ear can hear and with remarkable cleanliness.

Having accomplished a reasonably good high-frequency response, the engineers suddenly woke up to the fact a couple of years ago, that we weren't getting the proper low-frequency response. And so began the era of infinite baffles, horn loading, exponential horns, and many other approaches to the problem of better bass reproduction. Here again, the engineers have succeeded very nicely and there are many styles of enclosures utilizing many different principles which produce a very clean and satisfactory bass. So what was wrong with the music at the Fair, what is this "disgraceful" reproduction I am talking about? Well, it's just that the boys have really gone off the deep end. It is acknowledged that a really good, clean, low distortion bass response is best achieved with large size enclosures. But this last Fair proved that you can overdo a good thing. There were some enclosures exhibited which could well serve a 2000 seat theater let alone the confines of the average living room.

All right, so we have to have size for good bass quality, you say. Reluctantly I must agree, but it is not necessary to so overload these huge enclosures that all they sound like is the thunder of booming cannons.

There was so much resonance and "boom" in practically every room at the Fair that it was well nigh unbearable and many a person was noted walking out with disgust written all over his face. And as if the physical characteristics of these speakers

The opinions expressed in this column are those of the reviewer and do not necessarily reflect the views or opinions of the editors or the publisher of this magazine.

weren't bad enough, the personnel who demonstrated these monsters were aware of only one position for the bass control on their front ends. That was wide open for full boost, which only made a bad situation still worse. Gosh-a-mighty anyone who reads this column knows that I'm always talking about "big bass drum sounds and tympani explosions." Sure, I get a terrific kick out of the physical and emotional impact of good clean bass. But as I have so often stated in these pages before, we should not and can not lose our heads about things like this and forget that we are dealing with music.

Even though in many ways high-fidelity record reproduction is superior to actual concert hall performance, we must still try to stay within the bounds of musical good taste. The type of bass heard at the Audio Fair never was and never will be heard in a concert hall and is a distinctly unpleasant sound even from the high-fidelity standpoint. It is odd and certainly deplorable, that at this time, when high fidelity is really taking hold, that manufacturers should go out of their way to alienate the listening public. And believe me, alienation is the proper word, as many a musically sensitive person who has heard this assault on good taste can testify. To those of you who think I am over-emphasizing this subject, if you know a person who is professionally associated with audio and who attended the last Fair, ask him and see if I'm not right in my assertions. Is there an answer to this situation? Well, there are several answers:

One, of course, is to convince the demonstrators of audio equipment that it is not necessary to keep the bass control at full boost in order to impress a prospective customer. The other answer is not so easy of doing. That the enclosures must be large for truly successful bass reproduction is granted. That these enclosures and the speakers within them must be practical from a commercial standpoint in terms of ultimate cost to the buyer is also evident. These factors make the answer difficult because as I see it and as a number of my engineer friends see it, a great deal more rigid type of construction is necessary to eliminate the resonances which are the principal cause of the objectionable boominess. And I mean *really rigid*, more than is commonly known. Solid wood is not as satisfactory as plywood of the same thickness in the construction of enclosures; and if we try to go into especially heavy plywoods such as 2-inch thicknesses we run smack into a very formidable cost problem. This idea of greater rigidity in enclosures holds true whether it be a bass reflex or a horn loading type (even though horn loading is supposed to help eliminate some resonances). I really feel that the next step forward in the search for better reproduction of bass frequencies is

(Continued on page 137)

RADIO & TELEVISION NEWS

PHONE-PLUG AMPLIFIER

By

H. F. STARKE

and

C. W. MARTEL

Raytheon Manufacturing Co.



Fig. 1. The plug in use in receiver setup. (Inset) Close-up of phone-plug amplifier.

THE amateur, experimenter, or laboratory technician often wishes he had a small, simple amplifier to provide additional gain when he is logging a distant station or listening to the signal from an impedance bridge while attempting to balance it for minimum output. The availability of junction transistors now makes it possible to design and build an amplifier of a size never possible with tubes, even those using the lowest possible operating power.

This "phone-plug amplifier" is designed to plug into the phone jack of a receiver or other electronic instrument. All of the components fit inside the case of a conventional phone plug which is altered by building on to the rear portion a simple jack into which the plug from the earphones may be inserted. Fig. 1 shows a close-up of this unit and a view of it in use, plugged into a receiver with earphones plugged into the jack at the rear of the phone-plug amplifier. The particular amplifier shown was made with a transparent cover to replace the black Bakelite cover usually supplied by the phone plug manufacturer. Fig. 3 shows the amplifier with outer case removed.

The circuit of the unit is extremely simple as shown in Fig. 2A. The transistor is of the *p-n-p* junction type made by Raytheon and designated as the CK722. This will provide a gain of approximately 20 db when the output impedance is about 1000 ohms. The gain may be increased by 5 or 6 db if the Raytheon type CK721 transistor is used but the 20 db obtained with the CK722 is suitable for most requirements and has the advantage of using a lower cost transistor. The small mercury-type battery cells are available from Mallory and Ray-O-Vac. Each manufacturer has a slightly different cell design but any of these small cells can be used with but minor changes. The coupling condenser we used was manufactured by Fansteel but small electrolytics have since been announced by other companies, including Aerovox and Micumold so

Details on a compact transistor amplifier which will give a gain of approximately 20 db at 1000 ohms output impedance.

substitutions may be made here also. Resistor *R* should be adjusted for a collector current of about 0.5 milli-ampere when phones with an impedance of about 1000 ohms are used. Other phone impedances may be used but amplifier gain will vary as a result. Fig. 2 shows the values of the components used in our unit but the experimenter who builds this will have no difficulty in building a similar amplifier even though he uses some of the other types of batteries and condensers announced previously.

With the Ray-O-Vac 500D battery which was used in the unit illustrated, and with the transistor current drain adjusted to about 0.5 ma., the battery life will be about 200 hours. The constructor of this amplifier may find that he can obtain satisfactory performance for his purpose with less transistor current and thus obtain increased battery life. Also, the Mallory RM625 cell, which is but slightly larger, is rated for 300 ma. hours and will provide, at 0.5 ma. drain, a life of 600 hours in this application.

(Continued on page 80)

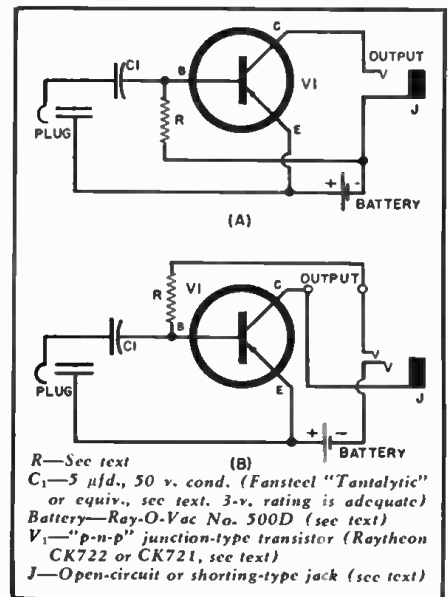
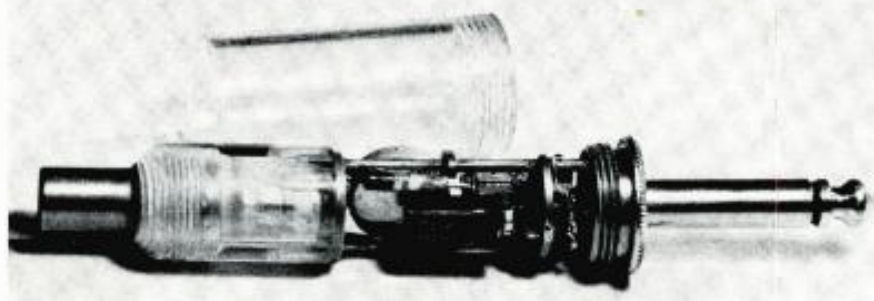

Fig. 2. (A) Circuit diagram of phone-plug amplifier using a "p-n-p" junction-type transistor. (B) Amplifier using a miniature three-contact, shorting-type jack.

Fig. 3. Over-all view of phone-plug amplifier with the outer case removed.



MY START IN TV SERVICING



The author checking voltages with his indispensable v.t.v.m.

Blow-by-blow case histories of the first 16 sets actually encountered by a new service technician.

NOT very long ago, TV was something which radiomen in the writer's hometown only talked about—and intended doing something about. Then, suddenly, the freeze was lifted, a local TV station scrambled onto the air, and a lot of radio service technicians, radio amateurs, and other radio people had genius thrust upon them: they were installing and servicing television sets.

The writer was one of these, and he kept a diary of the first couple of dozen service jobs tackled—with the thought that the notes would be helpful in subsequent servicing. Eventually, the troubles began to repeat—so the diary failed to grow. But in the first case histories are solutions to some of the troubles you are apt to encounter if you are just starting out—solutions which may save you time and money. And if you are an old timer, you may enjoy reading the symptoms in the case histories, and seeing how long it would take you to come up with an answer.

Actually, anyone intending to take a whirl at television servicing should make a real effort to get some kind of formal training in the subject, irrespective of his radio background. The writer has held an amateur license since 1932, had formal college training in communications engineering, and spent nearly a year in Signal Corps

radar and airborne radio schools. But the freeze lifting—plus an eager beaver station—caught him with his textbook down: studying unit 2 (antennas) of a 10-unit course on TV. Some semblance of TV training had to be pried out of books on the subject—in nothing flat—in order to help out a dealer friend who was naturally anxious to get his share of the rush of business in an area in which the nearest TV station (and hence experienced TV technicians) was nearly 500 miles away.

More knowledge, even of the textbook variety, would have saved a lot of time. For example, the very first set which the writer encountered just about made him abandon the whole project as a bad job!

Case 1—Picture tube dark, sparks jumping inside the high voltage cage: A quick check of a couple of service manuals suggested that the trouble (which developed in the first two hours of operation) might be in the high voltage circuit. Inasmuch as the vacuum-tube voltmeter and the high voltage probe hadn't arrived from the mail order supplier there wasn't much to go on. However, resistances of the various parts in the high voltage circuits were checked out, and everything seemed to be OK.

For luck, the high voltage transformer was changed. Still the same

By JAY STANLEY

problem: uncontrollable corona discharge and the hospital smell of ozone. *Nothing* seemed to be wrong, spraying various parts with insulating lacquer and carefully dressing leads didn't help a bit.

I was stuck and I knew it. So, more because I did not know what else to do than with the expectation of getting a quick solution, I phoned the local distributor for the brand of set to see if he had any ideas.

Fortunately, there was a visiting fireman in the form of a technician from the factory—and he *did* have a suggestion: the high voltage filter condenser (see Fig. 1) might be open. Sure enough, it was. A new ceramic condenser and the set settled down and worked beautifully.

Case 2—Brand-new set, fresh off the truck. Good sound, complete with raster, but no picture: Fortunately, the vacuum-tube voltmeter and the set arrived at the same time. Since the set being serviced was the usual inter-carrier variety, the trouble was probably between the video detector and the picture tube.

Using the peak-to-peak scale on the voltmeter, the signal was traced through the video amplifier. Finally, there was one lone part in the signal path between the video amplifier and the picture tube: a .1 μ fd. tubular condenser, pretty thoroughly buried. Moving it revealed the trouble—the condenser had broken loose on the picture tube end. Apparently the set had been shaken up on the trip, enough to break off the part. In thirty seconds the part was soldered in place and the set subsequently ran for 9 months before needing so much as a tube.

Case 3—Picture on a set being used as a demonstrator became progressively smaller in height, and height and linearity controls wouldn't "round out" circle on a test pattern: Easy—weak 6S4 vertical output tube. Who said TV servicing was tough?

Case 4—New set pulled out of carton for checking before promised immediate delivery to customer; no pix at all; very weak sound: Looked like another signal tracing job, so pulled chassis out. The peak-to-peak scale on the voltmeter showed no signal to amount to anything at the video detector and with the r.f. probe the story was the same in the video i.f. stages.

Apparently the trouble was in the tuner or in the first i.f. Decided to make voltage checks first of the i.f. stage, since it was easier to get at. In going around the tube socket pin 1 lug was found floating free in the air—

completely broken off from the socket. The heavy tuner had moved in shipment and jerked the lead. A little careful work with a razor blade made it possible to solder the lead in place, and the dealer (who had been nervously watching the clock while all of this was going on) had his set to deliver to the eager customer "who was expecting some company to see the new TV set."

At this point the writer made two mental notes: 1. Look things over good, it might save some skull scratching. 2. When the transportation companies really get down to business, anything can happen.

Case 5—Intermittent: picture would drop out of focus and show snow at the same time: The first suspicion was that the voltage to the focus coil was off—and this seemed to be somewhat true, at any rate, the voltage would change when the picture changed. The best approach seemed to be the laborious one of disconnecting the various voltage supply leads one by one. And sure enough, when the lead going to the 6BQ7 Standard Coil tuner assembly was taken loose, picture focus returned, and voltages went back to normal.

Then the writer "came to." The tuner, with its cascode circuit, has the two tubes effectively in series. A short on one section of the tube could cause the trouble. So the 6BQ7 was replaced, and the first tube in the set straightened out the voltage on the final tube in the circuit.

Case 6—Dark Picture Tube: This set was a little daisy—an ancient 7" a.c.-d.c. set which a neighbor had picked up in another city for \$20. The dealer had assured him that it was "all there"—but made no other promises.

Just like Case 5, voltages seemed to be a bit off, not much, but some; so a lot of time was spent checking out low voltage filter condensers in the selenium rectifier doubler circuit and in substituting rectifiers. Nothing seemed to help much, voltages remained just a little low all through the set.

Then I sat down and dug out the service notes on the set. The very first note "sound—no picture or raster" suggested checking a high-voltage, oil-filled condenser in the r.f. power supply. Replacing the condenser cleared up the trouble. Had the writer spent 10 minutes in reading instead of 2 hours in probing, well, some people have to be convinced the hard way!

Case 7—Streaks, picture tearing along individual raster lines, snapping sound in the speaker: This was a beautiful chance to demonstrate what not to do. Having heard snapping sounds before, and observed that upsets in the high-voltage circuit may cause a kind of streak in the picture tube, the high-voltage circuit was immediately suspected. Part by part it was checked out, but everything seemed to be perfect.

The writer noticed that in hooking

up another set that a similar condition was simulated when a screwdriver was shorted across the antenna terminals. Could it be that the trouble was in the tuner?

That it was; a 6J6 oscillator tube acting up. New tube—no more trouble.

Case 8—Picture would pull badly when contrast control advanced: This was the first model of the year's new line which had arrived. The writer immediately dug out some back copies of RADIO & TELEVISION NEWS which had carried a series of articles on "pulling." But none of the suggestions seemed to help. Everything checked out as described—but the set still pulled.

Sometimes discretion is better than digging, and besides, the set was from the distributor who had bailed me out with the first set I serviced. This time I took the set down, just to watch an expert go to work.

After I explained the trouble, he didn't go to work. It seemed that all of the new models with that particular chassis had the same symptom—which the manufacturer regarded as unimportant because it did not show up until the contrast was advanced slightly beyond the normal contrast level. The factory man and the writer agreed in their opinions of engineers who would ignore such obvious truths as the fact that 6 year olds don't know about scrambling up the picture. (In this particular set doing so was a cinch, because the control was on a ring knob directly under the volume control.)

Apparently the 6 year olds won out, because shortly, the factory issued dope on how to modify the set so that it would behave. The writer learned another lesson: be sure there is trouble before you butt your head against a wall.

Case 9—Picture compressed at the top, poor sound: This was a little like a doctor encountering a case of bunions and halitosis in the same patient. Apparently the odds had run out, and here was a set with two troubles at the same time.

Decided to tackle the picture first, and that was simple; another 6S4 vertical output tube had given up the ghost. A nice shiny new one brought the picture back up to size.

The sound was something else

Fig. 2. Pulse-width frequency control circuit, whose adjustment required more than a v.t.m., discussed in Case 13.

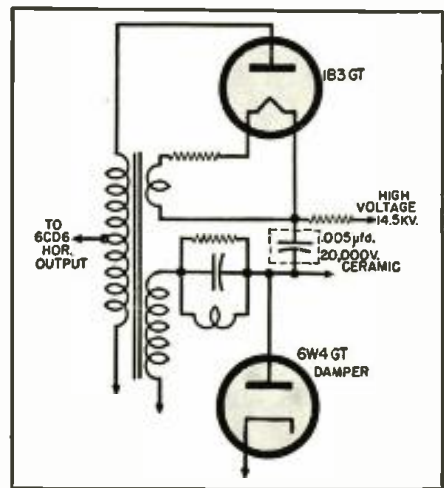
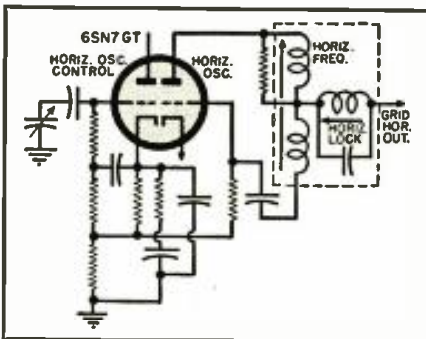

Fig. 1. Diagram of the high voltage circuit showing the condenser that caused the trouble given in Case 1.

again. Probably the ratio detector transformer needed touching up, and the service notes (we were beginning to take more stock in them after Case 6) said that it could be adjusted from a slot in the bottom of the cabinet below the chassis.

Five minutes of trying to hit the transformer were completely futile, so I decided to pull the chassis and see if my suspicions were right: that the hole was probably nowhere near the transformer. It wasn't. I made a mental note to write a nasty letter to the manufacturer, and adjusted the transformer until the sound dropped into place. Then, just for luck, checked the adjustment with the "centering" scale on the v.t.v.m., and found it was right on the nose.

Case 10—Buzzing sound in the audio which changed in strength with changes in the scene: This was one of those cases in which the doctor buries the patient and hopes that nobody ever digs him up.

At first blush the trouble seemed to be intercarrier buzz, and so the chassis was pulled out and the transformers in the ratio detector circuit carefully aligned with the v.t.v.m. The set sounded a lot better, so I collected my money and went home.

The next night, the customer was on the phone again. Same problem. This time I decided to pull the chassis into the shop.

At the shop I began to dig into the literature on "hum and buzz," and there in black and white was the suggestion that leakage in tube elements in the video i.f. or the tuner can cause cross modulation, and intercarrier buzz. The i.f. checked out okay, so the r.f. was next, working my way forward. The final tube checked (a tube type which I later came to suspect at the drop of a hat) was a 6BZ7. Replacing it cleared up the buzz completely, and also greatly reduced pulling which the set exhibited at times.

Case 11—Intermittent, picture would suddenly drop out with no appreciable change in sound: This set was another second-hand 7 inch "partless wonder."

(Continued on page 156)

The ELECTRONORGAN

By
RICHARD H. DORF
Audio Consultant

Part 3. Concluding article covers the construction of the filterboard, preamp, stop filters, and relay power supply.

IN THE first two parts of this article we covered the tone generators, the generator power supply, cabinet modifications, and construction of the plugboard and key switches. The only remaining portions of the construction are the filterboard, the preamplifier, the stop filters, and the relay supply. This data is covered in this, the concluding, article.

Fig. 22 is a closeup of the filterboard as it is seen from the rear of the organ case.

The job of transforming the sawtooth tones of the basic organ into tones which sound like pipe-organ stops is one of the most important aspects of this construction. The so-called "formant" principle, used here, recognizes that a particular tone quality is caused because certain inherent resonances and mechanical filtering characteristics of each musical instrument cause a given frequency's output characteristics for the instrument. A given instrument, for example, may be so formed that there is a pronounced rise in output at 800 cycles, with gradually decreasing output at lower frequencies and more sharply decreasing

output at higher frequencies. Another may have large output at lower frequencies with very gradually decreasing output as the frequencies rise. These formant characteristics vary widely and account for the differences in sound which enable us to recognize an oboe from a flute and a violin from a viola.

These frequency characteristics affect not only the fundamental tones played but, more important, they determine the harmonic or overtone structure of every note. If, for example, there is a resonance at 800 cycles, a 200 cycle note will have a prominent 4th harmonic; a 400 cycle note will have a prominent 2nd harmonic, and so on. Obviously, the structure of a tone differs according to its fundamental, which is quite different from the action of the *Hammond* organ where the harmonic structure of all notes is the same for a given drawbar combination. The "Electronorgan" is meant to be imitative of an actual instrument while the *Hammond* is not.

The actions of these natural mechanical filters can be approximated by electrical filters, as is done in the

Baldwin and *Minshall* organs as well as a few others. This is the system followed in the "Electronorgan."

Fig. 23 is a schematic diagram of the swell section of the filterboard. SO_{sw} on this filterboard connects to the swell key switch assembly. No circuit diagram of this assembly has been included because of its similarity to the great key switch assembly shown in Fig. 21, Part 2. The text accompanying Part 2 describes this similarity and describes the output connector as being similar to P_{sw} of Fig. 21. It is this output connector for the swell key switch assembly that goes to SO_{sw} .

Rather than build in the tone filters, the writer has provided an octal socket for each filter. The filters, Fig. 27, are made up of individual cans which plug into the sockets. This allows for future experimentation with different filters. As shown in Fig. 23, the ground, 4' and 8' connections from SO_{sw} become busses terminating at each socket, SO_{in} through SO_{sw} , so that any filter may use any input. In addition, 4' and 8' tones are brought in from the great key switches through a "great-to-swell" coupler switch so that, when desired, tones keyed on the great manual can sound through the swell filters.

The output of each filter, Fig. 27, is fed through pin 8 of its associated socket and this output is connected to the arm of a s.p.d.t. relay contact. Each relay may be controlled by one of the stop knobs shown in Fig. 1 (Part 1) the relay contacts of which are shunted by SO_{sw} . Each relay is eliminated by a condenser to eliminate clicks.

Certain tone qualities are almost completely lacking in even harmonics; they have that hollow "woody" quality. The sawtooth tones contain all harmonics. To eliminate the even harmonics, 4' and 8' tones are mixed in the outphaser circuit shown in Fig. 23 in such a way that the resulting tone at the junction of R_{12} and R_{11} is almost symmetrical, consisting mainly of odd harmonics. This output provides an additional filter input bus to the octal sockets for some of the filters.

The outputs of all the relay contacts

Fig. 22. Closeup view of the filterboard as seen from the rear of the organ case.

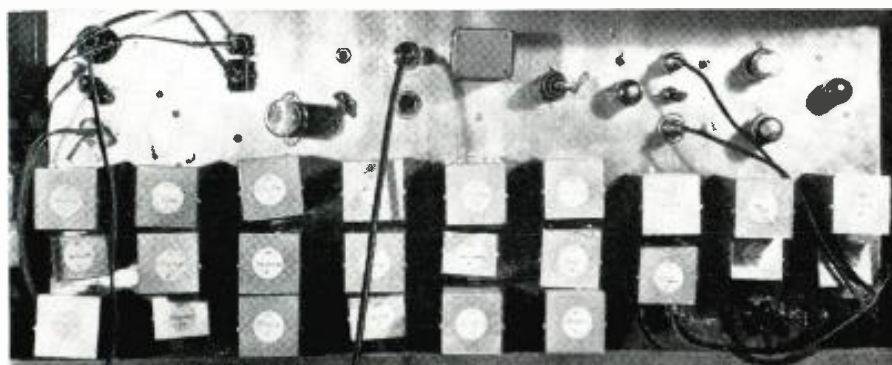

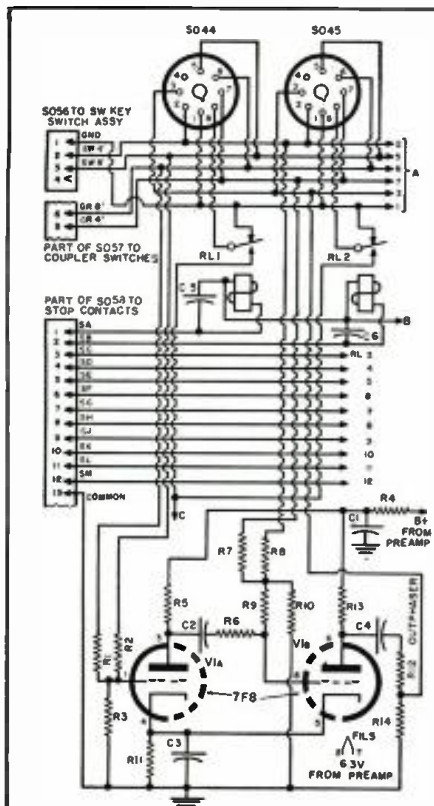

A—TO CORRESPONDING TERMINALS OF SO46-SO55
 B—TO ALL RELAYS AND RELAY VOLTAGE FROM PREAMP.
 C—SWELL OUTPUT TO PREAMP AND TO BOTTOM CONTACTS OF ALL RELAYS

R_1, R_2, R_3, R_4 —33,000 ohm, $\frac{1}{2}$ w. res. $\pm 10\%$
 R_5 —15,000 ohm, $\frac{1}{2}$ w. res. $\pm 10\%$
 R_6 —4700 ohm, 2 w. res. $\pm 10\%$
 R_7, R_8, R_9, R_{10} —47,000 ohm, $\frac{1}{2}$ w. res. $\pm 10\%$
 R_{11} —47,000 ohm, $\frac{1}{2}$ w. res. $\pm 10\%$
 R_{12} —22,000 ohm, $\frac{1}{2}$ w. res. $\pm 10\%$
 R_{13} —5600 ohm, $\frac{1}{2}$ w. res. $\pm 10\%$
 R_{14} —470 ohm, $\frac{1}{2}$ w. res. $\pm 10\%$
 R_{15} —10,000 ohm, $\frac{1}{2}$ w. res. $\pm 10\%$
 R_{16} —3900 ohm, $\frac{1}{2}$ w. res. $\pm 10\%$
 C_1 —40 μ f., 450 v. elec. cond.
 C_2 —.05 μ f., 400 v. cond.
 C_3 —25 μ f., 25 v. elec. cond.
 C_4 —25 μ f., 400 v. cond.
 C_5, C_6 —100 μ f., 12 v. elec. cond.
 RL_1, RL_2 —S.p.d.t. relay, 2 volt, 18 ma. coil
 SO_{44}, SO_{45} —Octal tube socket with saddle and ground lugs
 V_1 —7F8 tube

Fig. 23. Schematic diagram showing part of the swell filterboard. This is a section of box shown as "Filters" in Fig. 15 (Part 2). Although only two swell filter sections are shown, the entire assembly consists of 12 swell filters. The wiring for the balance of the unit not shown is identical to the ones indicated. The various swell filters are interchangeable. SO_{46} is to be connected to the swell key switch as shown in the block diagram, Fig. 15 in Part 2.

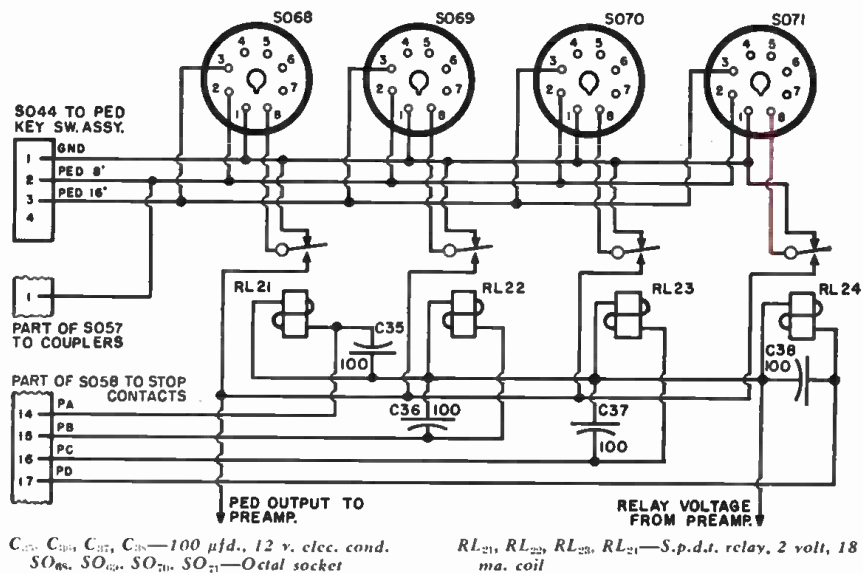

$C_{35}, C_{36}, C_{37}, C_{38}$ —100 μ f., 12 v. elec. cond.
 $SO_{68}, SO_{69}, SO_{70}, SO_{71}$ —Octal socket
 $RL_{21}, RL_{22}, RL_{23}, RL_{24}$ —S.p.d.t. relay, 2 volt, 18 ma. coil

Fig. 24. Wiring diagram of the pedal filterboard. SO_{11} connects to the pedal key switch (See Figs. 15 and 20 in Part 2). Grounding of the normally-closed relay contacts is optional. This filterboard consists of the four sections shown.

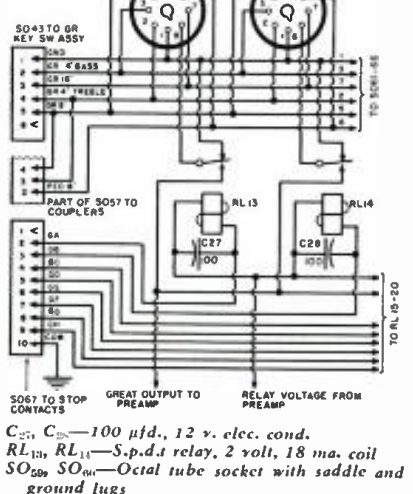

C_{27}, C_{28} —100 μ f., 12 v. elec. cond.
 RL_{13}, RL_{14} —S.p.d.t. relay, 2 volt, 18 ma. coil
 SO_{59}, SO_{60} —Octal tube socket with saddle and ground lugs

Fig. 25. Wiring diagram shows two sections of the great filterboard. The entire filterboard consists of eight sections. The balance of the units, not shown, are wired identically with the two indicated. SO_{13} connects to the key switch assembly. For details see Figs. 15 and 21 in Part 2.

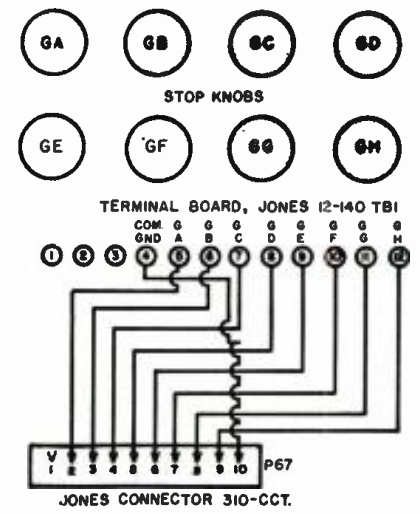

Fig. 26. Great stop control diagram. Each knob controls one s.p.s.t. normally-open switch. One side of each switch goes to a terminal as indicated. One side of each switch is common to terminal 4. The Jones connector, P_{67} , connects to SO_{17} on the filterboard shown in Fig. 25. Similar arrangements are made for the swell and pedal knobs. The great stop control knobs are located on the right hand side of the console as shown in Fig. 1 of Part 1.

are connected together and go to the preamplifier input. Figs. 24 and 25 are schematics of the pedal and great sections of the filterboard, respectively. They function in the same way as the swell section shown in Fig. 23. Fig. 26 shows how the stop knobs are connected to the cable and connector, thence to the great filterboard relay connector SO_{67} . Similar arrangements exist for the swell and pedal knobs. The relays used are very small ones, obtained as surplus. The constructor should investigate the possibilities before starting to work. The main criterion is that when the relays close they should make very little noise. All noise can be

eliminated by wiring the filter outputs to the stop switches directly. If the relays are used, however, they must be d.c. types as the coils are close enough to the signal lines to cause hum unless these are used.

The remainder of the filter board is diagrammed in Fig. 29. The output of the great filter section—all the relay contacts in common—goes to the No. 1 grid of V_1 . The output of the pedal filters goes to the arm of RL_1 , which is similar to the filter relays and may, if desired, be replaced by a simple switch. RL_1 is controlled by the "pedal-to-swell" shoe tab on the coupler panel. With the relay de-energized, the pedal

output goes to the arm of R_2 , a balance control which is set after installation for the proper proportion of "pedal-to-great" volume.

A similar input tube, V_2 , is provided for the swell filter output. When the relay is energized the pedal output is switched to the arm of R_3 , a similar balance control. There are separate pedal-operated volume controls for swell and great and the purpose of RL_1 is to allow either the great or swell control to operate the pedal volume simultaneously, if so desired.

The outputs of V_1 and V_2 go to three-contact microphone connectors SO_{10} and SO_{19} . The inset diagram (lower

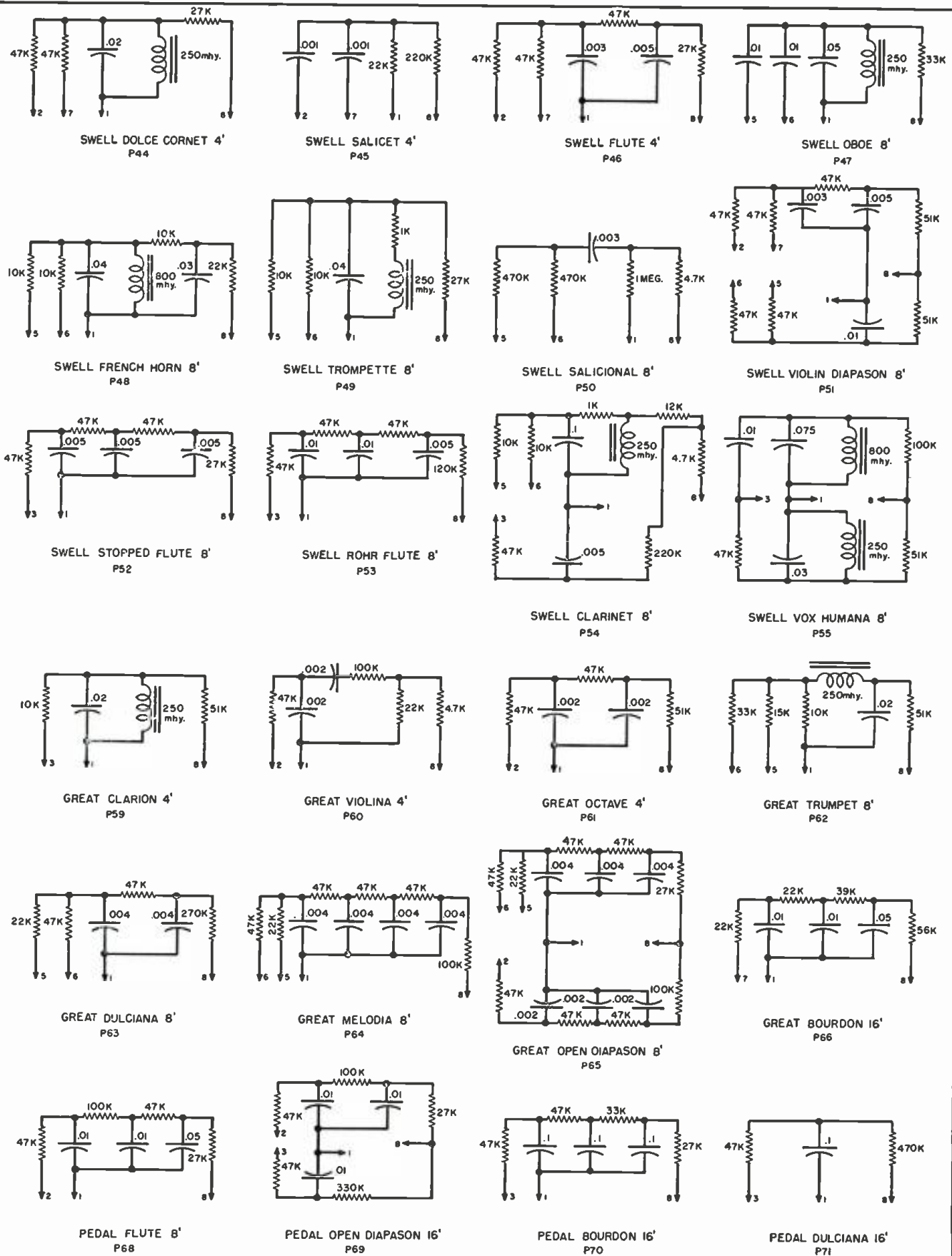
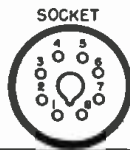
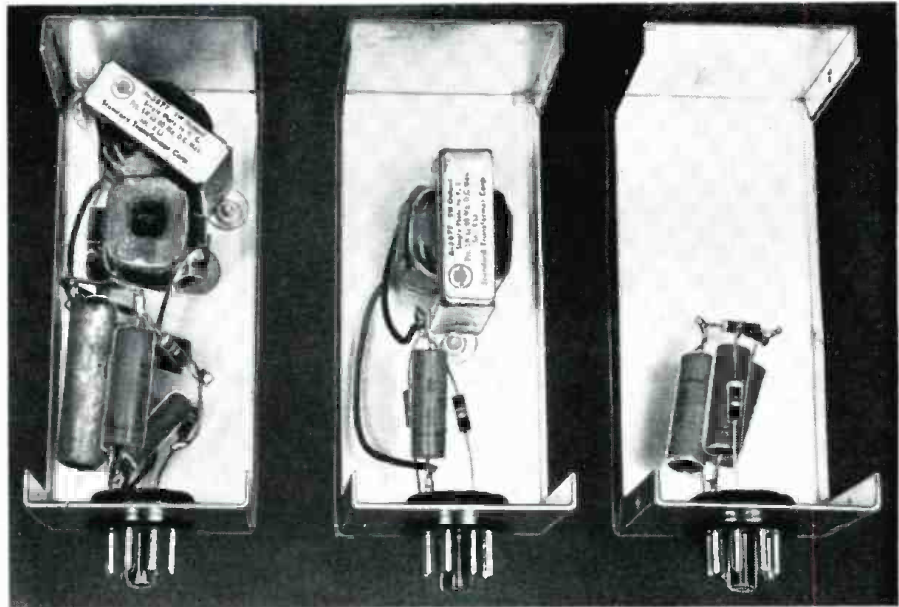

Fig. 27. Wiring diagram of the filters. All of them are assembled individually and each wired to an



octal plug. See Fig. 23 for placement of the swell filters, Fig. 24 for pedal, and Fig. 25 for great filters.

Fig. 28. Three of the filter assemblies. From right to left: "Pedal Flute 8'," "Great Clarion 4'," and "Swell Vox Humana 8,'" Twenty-four filters are used in the organ.



right hand corner of Fig. 29) shows how the volume control potentiometers are connected to SO_{68} and SO_{69} by a two-conductor shielded microphone cable terminating in P_{68} and P_{69} . These controls are geared to the expression pedals.

The arm of each volume control is connected through a 100,000 ohm resistor (R_{11} and R_{12}) to the No. 1 grid of V_3 , which is connected as an ordinary two-stage voltage amplifier. R_{17} is a preset volume control which is set at the time of installation to provide the maximum desired organ output.

V_4 is triode-connected as the final

Fig. 29. Schematic of organ preamp. A high-quality amplifier and speaker system are needed as well. "Great" and "Swell" volume controls are shown, lower right.

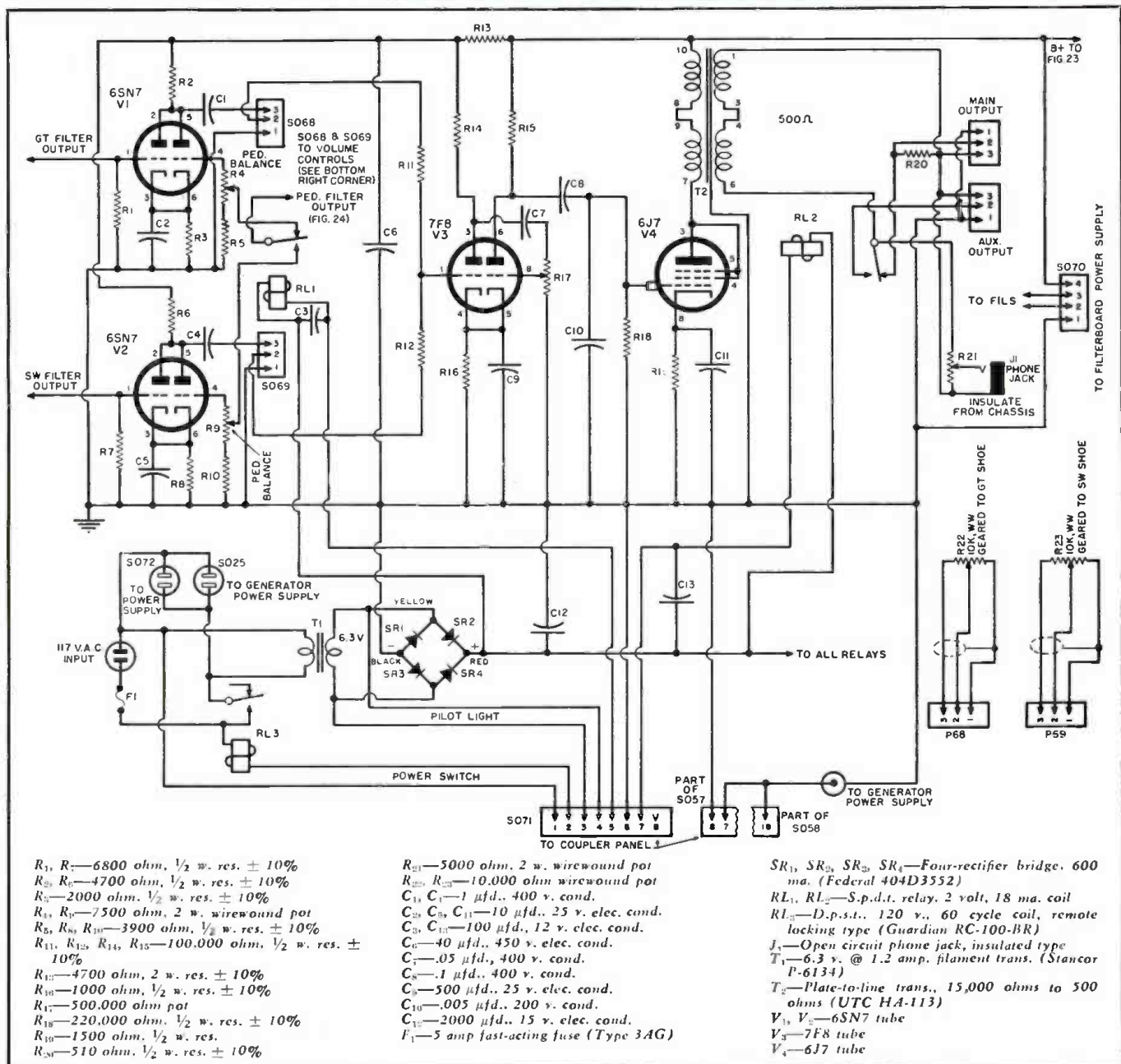

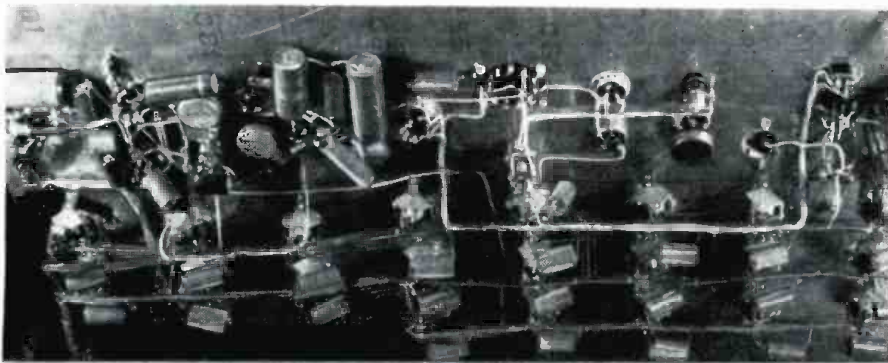

METAL CASING FOR SWELL KEY SWITCHES



Fig. 30. Rear view of the filterboard taken from the front of the organ console.

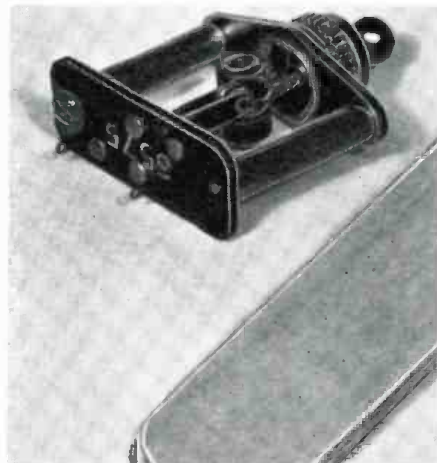
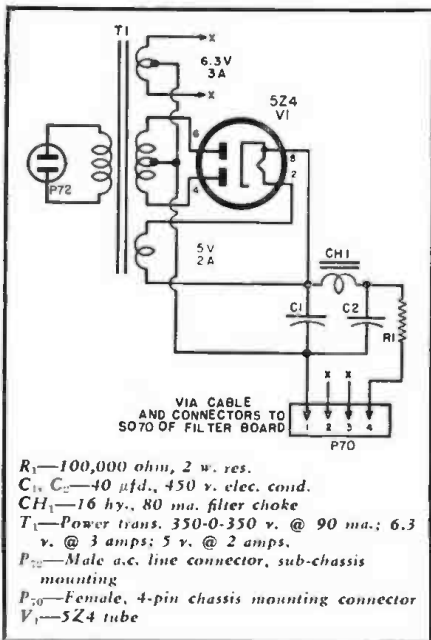
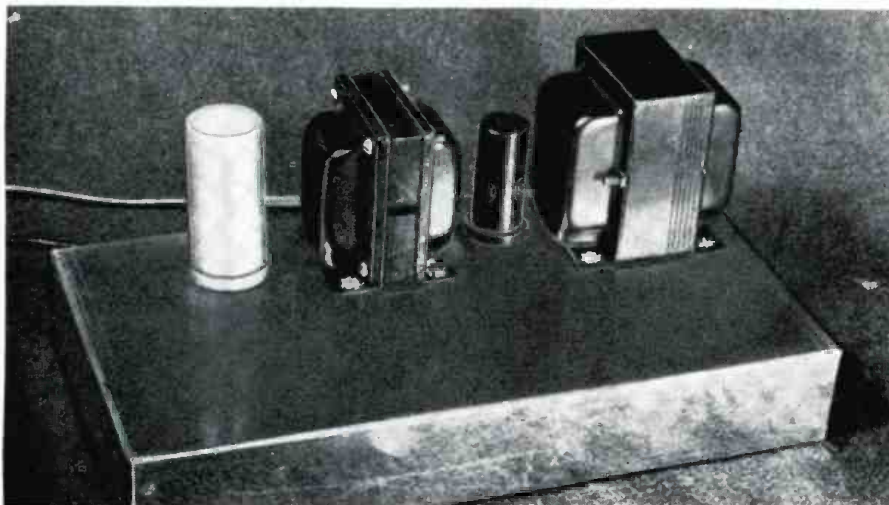

Fig. 32. Components used in constructing the tabs for the coupler panel.

Fig. 31. The filterboard power supply. It is set on the floor of the organ case.

Fig. 33. Filterboard power supply. It may be built on smaller chassis if desired.



output stage, with transformer T_2 providing a 500-ohm output line. The secondary of T_2 is normally connected through the contacts of RL_2 to the main output connector which has a 500-ohm resistor shunted across it. In ordinary service this output is fed to the grid of an ordinary high-quality power amplifier and speaker system. No input transformer is needed at the amplifier so the 500 ohm resistor, R_{20} , is the dummy load for T_2 . When RL_2 is energized by the auxiliary output tab on the coupler panel, the output is switched to the auxiliary output connector which the writer couples, through a suitable pad, to the input of a broadcast-studio type speech input system for recording. J_1 is provided so that headphones may be plugged in either for monitoring when recording or for listening when it is too late at night to use the amplifier and speaker. R_{21} controls the headphone volume. Relay RL_2 may, like the other relays, be replaced by a switch, if desired.

Fig. 29 also shows the line input connections. The line is connected to the 117-volt input and SO_{22} and SO_{23} are provided for the generator and filterboard power supplies. RL_3 is an impulse-type ratchet relay operated by a push-button on the coupler panel. It may be replaced by an ordinary a.c. switch if desired. Power for the relays is provided by the selenium rectifier bridge, SR_1, SR_2, SR_3 , and SR_4 , and the filament transformer.

Fig. 30 is a rear view of the filter board taken from above and in front of the organ console. The metal casing for the swell key switches can be seen between the key levers and the filterboard. The arrangement of parts on the board can be seen in the rear view of Fig. 22. The outphaser is at the far right with the rest of the electronic components in a line going left. The power connectors are at the far left. The twenty-four metal boxes are plugged into the octal filter sockets and contain the filters.

The power supply for the filterboard tubes is shown schematically in Fig. 31 and photographically in Fig. 33. The 7" x 13" x 2" chassis is bigger than necessary but was used because it was on hand. It is simply placed on the floor of the organ case at the player's right. The generator power supply is similarly placed on the left side of the case.

The front of the coupler panel, located just above the swell manual, is shown in Fig. 35 and its schematic is given in Fig. 34. Reference to the other circuit diagrams associated with the coupler and the earlier text material will clarify its operation.

There was originally a board in this position on the console in which the original tablet switches were mounted. The slot, which was in the original board, and the board itself were covered with a piece of tempered *Masonite* and the tab switches mounted over the original slot. The momentary push-button switch and the pilot light of Fig. 34 are standard electronic items.

(Continued on page 120)



International

SHORT-WAVE

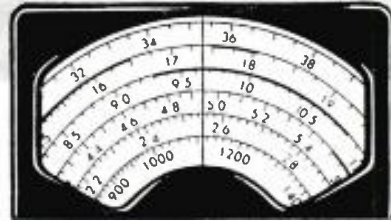

Compiled by KENNETH R. BOORD

FRANCE—Robert Mercier, an *ISW DEPARTMENT* monitor, has established the "first international radio club in France"—CARM (Club des Auditeurs de la Radio Mondiale). The club's house organ is now in French but Robert hopes to add an *English* section soon for overseas members; details on membership can be obtained from CARM, 1, rue Pasteur, Juvisy-sur-Orge, Seine-et-Oise, France.

Japan—The Japanese Short Wave Club, only international radio club in all of Asia, desires members anywhere in the world, and particularly in North America. The club's house organ, "*SW-DX Guide*," is entirely in *English*. This club provides many services for its membership and issues such certificates as VAC (Verified All Continents) for QSL cards, and XAC (Exchanged All Continents) for SWL cards. Arrangements can be made for airmail delivery of the bulletin to members in USA, Canada, Australia, and New Zealand. QRA is P.O. Box 29, Sendai, Japan.

* * *

Around the World

Algeria—Radio Algerie, 6.160, noted 1530 with Arabic program of music and vocals; closes 1745. (Pearce, England)

Andorra—Radio Andorra, 5.996A, noted with music 1732-1800. (Cox, Dela.) Is at excellent level in Britain 1900. (Catch)

Anglo-Egyptian Sudan—Radio Omdurman, 7.090A, noted on Wed. 1614 with "Col. Bogey March," then news for South Sudan to 1130. (Pearce, England) Heard on measured 7.078 in Arabic 2315-2345. (Ferguson, N. C.)

Argentina—Radio Splendid, 9.310, noted 1900. (Zahner, Md.)

Australia—VLM4, 4.920, Brisbane, noted 1450 with test, opening 1500 with news, weather forecast; VLX4, 4.897A, Perth, heard opening 1700 with news. (Pearce, England) VLB9, 9.58, noted 0245 at good level. (Calos, Calif.)

Belgium—Belgian Congo—ORU5, 6.000, Brussels, noted 1330 with news; on Wed. with DX session 1336A. (Pearce, England) Brussels has moved from 9.767 to (winter) channel of 6.085, heard to North America 1930-2200. (Friant, W. Va.; Zahner, Md., others) Is still relayed by OTC, 9.655, Leopoldville. (Middleton, O.) ORU, 15.335, noted recently 0938 in language; still on air, but weaker, 1030. (Ferguson, N. C.) OTM, 9.380A, Leopoldville, noted 1410 with varied mu-

sic; closed 1600 with anthem; has news in Flemish around 1553. (Pearce, England)

Brazil—Location of the Brazilian on 11.925 has been cleared up by Villela, Md., formerly of Brazil, who says it is definitely Sao Paulo's "Radio Bandeirantes," ZYR78. "Bandeirantes" stands for the Sao Paulo "pioneers" who penetrated deep into the interior of the country and extended its borders almost to the Andes in the 18th Century. ZYR78 is parallel with ZYR77, 6.185. "Radio Bandeirantes" on m.w. PRH9, 840 kc., stays on the air all night but the s.w. transmitters close at 0030; announces QRA of Rua Paula Souza 181, Sao Paulo, Brazil, and since has only recently started s.w. operations, may be interested in reception reports.

Jensen, Wis., notes Radio Tamoiu, 9.610, in Portuguese at good level 1830-1900. Radio Nacional, 9.72, heard with announcements in *English* during musical session 2200-2230 (at least some days). Schedules of Brazilian stations are one hour earlier now during Brazilian Summer Time to March 31.

Dave Lund, *ISW Monitor* for several years, uses a Hallicrafters S-40B, a BC-454B, and a two-tube home-built receiver. His antenna system consists of a 300-ohm folded dipole and a 30-ft. straight-wire. He has 20 countries confirmed on the international short-wave b.c. bands and 38 confirmations on the amateur radio bands.



British Guiana—ZFY, 5.981, Georgetown, noted 1745 with local talent session. (Cox, Dela.) With "The Alarm Clock Club" session 0500. (Parsons, Va.)

British Honduras—Belize, 3.300, noted closing with "God Save the Queen" 2133A at excellent strength. (Jannis, S. C.) Sign-off seems to vary. (Ferguson, N. C.) Noted with news in *English* 2000-2010, then news in Spanish. (Cox, Dela., others)

British New Guinea—VLT6, 6.130, noted 0600 with news. (Jensen, Wis.)

Bulgaria—Radio Sofia, 7.671, noted with *English* 1615-1645. (Pearce, England) The *English* schedule to North America for winter appears to be 1745-1800, 2000-2030, 2300-2330 all over 9.70. (Bellington, N. Y.; Karrer, Pa.)

Canada—VE9AI, 9.54, Edmonton, Alta., is heard at weak level around 1830. (Zahner, Md.) Noted with news 2215. Vancouver, 6.050A, has sports results (USA and Canada) 0200-0215 Sat. (Kahan, Calif.) CHNX, 6.130, Halifax, N. S., is heard in Britain 1745. (Patrick)

Cape Verde Islands—CR4AB, Radio Clube de Mindelo, St. Vincent, on 7.180, is very seldom reported heard, but Hardwick, N. Z., found it recently at weak level 1706 to 1727 fade-out. (Radio Amateur, London) CR4AA, Praia, currently uses 5.895, 7.400A daily 1530-1700. (URDXC)

Ceylon—Colombo, 9.57, noted 0630 with VOA relay of news to Far East. The Commercial Service, 15.120, heard 2115 with news and musical session. (Sanderson, Australia) Is noted on 11.974 with "Top Tunes of the Week" on Sat. 1030-1100. (Persson, Bengtsson, Sweden)

China—Radio Peking announces *English* for 2200 on 11.69, 15.06; 0400 on 15.17, 15.06, 11.69, 10.26, 9.04, 7.50, 6.10; 0830 on 15.06, 11.69; at 2200 is about the same on 11.69, 15.06. (Gay, Calif.) The 7.50 has been nearer 7.45 lately with the *English* session 0400. (Balbi, Calif.) Noted on measured 15.064 and 15.093 around 1930 with native program. (Ferguson, N. C.) Shanghai noted on new 6.82 parallel (Continued on page 82)

(Note: Unless otherwise indicated, all time is expressed in American EST; add 5 hours for GCT. "News" refers to newscasts in the English language. In order to avoid confusion, the 24 hour clock has been used in designating the times of broadcasts. The hours from midnight until noon are shown as 0000 to 1200 while from 1 p.m. to midnight are shown as 1300 to 2400.) The symbol "V" following a listed frequency indicates "varying." The station may operate either above or below the frequency given. "A" means frequency is approximate

THIS BOOK HELPS YOU

Make Increased Profits

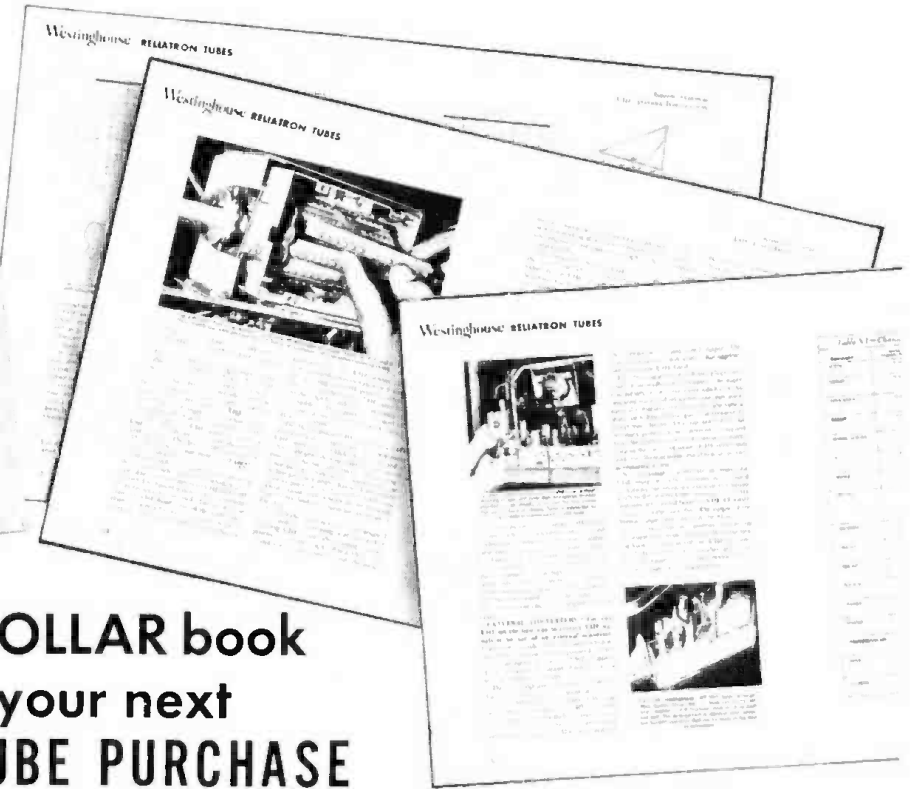
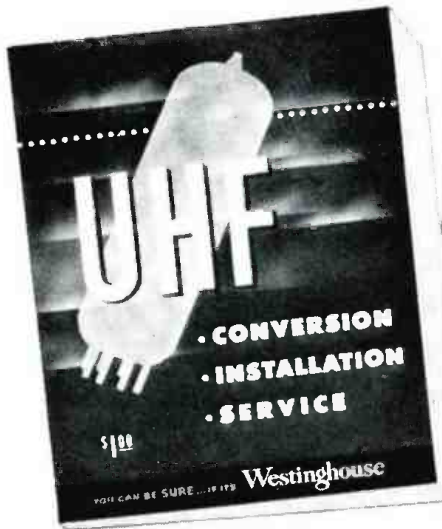

Get this ONE DOLLAR book
FREE with your next
 25-TUBE PURCHASE

This newest, most helpful book on UHF conversions is yours free when you buy 25 RELIATRON receiving tubes or one picture tube from your Westinghouse Distributor.

This vital handbook covers conversion data, tuners and converters, antenna installations, channel frequency charts, station coverage, and many other necessary, conveniently arranged facts you will need.

There's a gold mine in UHF conversions. And this book will help you make the most out of

the biggest profit opportunity since television came alive.

Get this dollar value for no extra charge with your next order of 25 tubes! For your nearest Westinghouse Distributor, see the list of all Distributors of Westinghouse RELIATRON Tubes on the opposite page.

Act Now for
UHF PROFITS

See Westinghouse Tube Listings in 1954 Photofact Folders.

ET-95046

YOU CAN BE SURE...IF IT'S
Westinghouse

RELIATRON TUBES
TM

WESTINGHOUSE ELECTRIC CORPORATION, ELECTRONIC TUBE DIVISION, ELMIRA, N. Y.

Get the Newest, Finest
UHF Conversion Handbook
 from one of these Westinghouse Tube Distributors
FREE with your next 25-tube order

ALABAMA

Birmingham — James W. Clary Co.
 Birmingham — Moore-Handley Hardware Co.
 Mobile — Moore-Handley Hardware Co.

ARKANSAS

Little Rock — Southern Radio Supply

CONNECTICUT

Bridgeport — Hatry of Bridgeport
 Danbury — Pilgrim Electronics Co.
 Hartford — Hatry of Hartford
 New Haven — Hatry of New Haven
 Stamford — Hatry of Stamford
 Waterbury — Hatry of Waterbury

DELAWARE

Wilmington — D & M Radio Sales & Service Co.

DISTRICT OF COLUMBIA

Washington — Electronic Wholesalers, Inc.
 — Silberne Radio & Electronics Co.

FLORIDA

Jacksonville — Bay Co.
 — Thurow Distributors Inc.
 Miami — Herman Radio Supply Co.
 — Thurow Distributors Inc.
 Orlando — Thurow Distributors Inc.
 Pensacola — Grice Radio & Electronics Supplies
 St. Petersburg — Thurow Distributors Inc.
 Tallahassee — Thurow Distributors Inc.
 Tampa — Thurow Distributors Inc.
 West Palm Beach — Thurow Distributors, Inc.

GEORGIA

Atlanta — Herndon-Thomas Electronics
 — Specialty Distributing Co.
 — Yancey Co., Inc.
 Albany — Specialty Distributing Co.
 Augusta — Specialty Distributing Co.
 Macon — Specialty Distributing Co.
 Savannah — Specialty Distributing Co.
 — Yancey Co., Inc.

ILLINOIS

Aiton — Radonics Alton, Inc.
 Chicago — Broadwin Radio & TV, Inc.
 — Chauncey's, Inc.
 — Clayton Radio Parts
 — Irving Joseph, Inc.
 — J. G. Bowman & Co.
 — Radio Parts Co.
 — Walker-Jimieson, Inc.
 Danville — Bud Electronic Supply Co.
 Elgin — Elgin Electronic Supply
 Joliet — Joliet Radio Supply
 Kankakee — Radio Doctors Supply House
 Oak Park — Melvin Electronics, Inc.
 Peoria — Warren Radio Co.
 Rockford — Superior Radio Co.
 Rock Island — Tri-City Radio Supply, Inc.

INDIANA

Angola — Shaw Engineering Co.
 Columbus — H. A. Williams & Co.—Radio Parts
 Evansville — Hutch and Son
 Ft. Wayne — Wall Distributing Co.
 — Warren Radio Co.
 Hammond — Broadwin Television & Radio,
 Inc. of Indiana
 Indianapolis — Graham Electronics Co. Inc.
 — Meunier Radio Supply Co.
 — Warren Radio Co.
 Marion — Mobile Radio Supply Co.
 Terre Haute — Archer & Evinger
 Valparaiso — Jess Bowman & Assoc.

IOWA

Cedar Rapids — Gifford-Brown, Inc.
 Council Bluffs — World Radio Laboratories
 Davenport — Tri-City Radio Supply
 Des Moines — Gifford-Brown, Inc.
 — Radio Trade Supply Co.

KANSAS

Pittsburg — Pittsburg Radio Supply
 Topeka — Overton Electric
 Wichita — Radio Supply Co.

KENTUCKY

Lexington — Lex-Tronics
 Louisville — Peerless Electronic Equipment Co.
 — Universal Radio Supply Co.
 Paducah — Warren Radio Co.

LOUISIANA

Baton Rouge — 'Ole Miss Supply
 New Orleans — Atlas Radio Supply
 — Crescent Radio & Supply Inc.
 — 'Ole Miss Supply
 — Pelican Radio Supply
 Sulphur — General Electronic & Engineering
 Service Corp.

MAINE

Hallowell — Powell Radio Supply

MARYLAND

Baltimore — Wholesale Radio Parts Co. Inc.

MASSACHUSETTS

Boston — Commercial Radio Corp.
 — Gerber Radio Supply Co.
 — Lincoln Electronic Supply Corp.
 — Radio Wire Television, Inc.
 Lynn — Essex Electrical Supply Co. Inc.
 Norick — Willett Radio Supply
 New Bedford — E. A. Ross & Co.
 Springfield — Regent Sales, Inc.

MICHIGAN

Battle Creek — Electronic Supply Corp.
 Benton Harbor — Benton Electronic Supply
 Co., Inc.
 Detroit — Glendale Electronic Supply
 Flint — Lifsey Distributing Company
 Grand Rapids — Radio Parts, Inc.
 — Wholesale Radio Co.
 Highland Park — Hi-Park Distributor
 Jackson — Matteson Electronics, Inc.
 Muskegon — Bell Laurim Electronics, Inc.
 Pontiac — Electronic Supply Co.

MINNESOTA

Duluth — Lew Bonn Co.
 Minneapolis — Electronic Center, Inc.
 — Lew Bonn Co.
 St. Paul — Lew Bonn Co.

MISSOURI

Kansas City — Manhattan Radio Supply
 — Radiolab
 St. Louis — Van Sickle Radio Co.
 — Radonics Co.

NEW JERSEY

Hackensack — American Distributing Co.
 Hillside — Sherwood Distributors, Inc.
 Jersey City — Hallmark Electronics Corp.
 Manville — Masters TV Supply Co.
 Newark — Emerson-New Jersey, Inc.
 — Radio Wire Television, Inc. of N.J.
 — Variety Electric Co., Inc.
 North Bergen — American Distributing Co.
 Paterson — Jersey Electronic Distributing Co.
 Perth Amboy — Bennett's Radio Supply
 Teterboro — Van Dusen Aircraft Supplies
 Trenton — Allied Electrical Appliance Parts, Inc.

NEW YORK

Albany — Air Waves Electronic-Radio Dist. Co.
 Binghamton — Stack Electronic Supply Co.
 Brooklyn — Ace Electronics
 — Bay Electronic Distributors
 — Benray Electronics Corp.
 — Hygrade Electronics, Inc.
 Buffalo — Buffalo Electric Co. Inc.
 — Radio Electric Products, Inc.
 Elmira — Le Valley McLeod, Inc.
 Fredonia — Barker-Higbee, Inc.
 Ithaca — Stallman of Ithaca, Inc.
 Mineola — Emerson-Long Island, Inc.
 Monticello — Fleisher Distributors, Inc.
 Newburgh — Chief Electronics, Inc.
 New Rochelle — Transvision, Inc.
 New York City — Barry Electronic Corp.
 — Bay Electronic Distributors
 — Emerson-New York, Inc.
 — House of Electronics
 — Magic-Vue Television Corp.
 — Midway Radio &
 — Television Corp.
 — Milo Radio & Electronics Corp.
 — Radio Wire Television, Inc.
 — Sanford Electronics Corp.

Patchogue — South Bay Radio Distributors
 Poughkeepsie — Chief Electronics, Inc.
 Rochester — Maseline Radio & Electronic
 Equipment, Inc.

Rome — Rome Electronic Supply
 Staten Island — B & D Distributing Co.
 Syracuse — Karl-Williams Co., Inc.
 Troy — Troy Electronics Distributing
 Utica — Electronic Laboratories & Supply Co.
 White Plains — Emerson Radio Westchester, Inc.

NORTH CAROLINA

Charlotte — Dixie Radio Supply Co.
 — Westinghouse Electric Supply Co.
 Greensboro — Westinghouse Electric Supply Co.
 Hickory — Victor Radio TV Supply Co.
 Raleigh — Raleigh-Allied Electronics, Inc.
 — Westinghouse Electric Supply Co.

Salisbury — Leonard Electronics of
 Salisbury, Inc.

OHIO

Akron — Sun Radio Co.
 Canton — Burroughs Radio, Inc.
 Cincinnati — Molub & Hogg
 — Mytronic Co.
 — Radio TV & Refrigeration
 Supply, Inc.
 Cleveland — Radio Electronic Parts Corp.
 Columbus — Buckeye Electronics
 — Electronic Supply Corp.
 — Whitehead Radio Co.
 Dayton — Allied Supply Co., Inc.
 — Statts-Friedman Co.
 Lima — Allied Supply Co., Inc.
 Mansfield — Burroughs Radio Inc.
 Marion — Servex Distributing Co.
 Toledo — Lifetime Electronics
 — Warren Radio Co.
 Warren — Radio Specialties
 Youngstown — Radio Parts Co.

OKLAHOMA

Oklahoma City — Dulaney's
 — Electronic Supply Co.
 Tulsa — S & S Radio Supply

PENNSYLVANIA

Allentown — Radio-Television Supplies
 Braddock — Marks Parts Co.
 Erie — B & D Wholesale Distributing Co.
 Harrisburg — Harrisburg Radio Laboratory
 Supply
 Hazleton — Moyer Electronic Supply Co., Inc.
 New Brighton — Television Parts Co.
 Philadelphia — Allied Elec. Appliance Parts, Inc.
 — Almo Radio Co.
 — Burnett Bros. Radio Co.
 — Herbach & Rademan Co.
 Pittsburgh — Cameradio Co.
 — Radio Parts Co. Inc.
 — Tydings Co.
 Scranton — General Radio & Refrigeration Co.
 — Penn Electrical Engineering Co.
 Wilkes-Barre — General Radio & Electronic Co.
 York — York Radio & Refrigeration Parts

RHODE ISLAND

Providence — Television Accessory House

SOUTH CAROLINA

Columbia — Dixie Radio Supply Co.
 — Westinghouse Electric Supply Co.
 Florence — Dixie Radio Supply Co.
 Greenville — Dixie Radio Supply Co.
 — Westinghouse Electric Supply Co.
 Spartanburg — McElhanney Co., Inc.

TENNESSEE

Chattanooga — Mills & Lupton Supply Co.
 — Specialty Distributing Co.
 Kingsport — Chemcity Radio & Electric Co.
 Knoxville — Chemcity Radio & Electric Co.
 Memphis — Electronic Supply, Inc.
 — McGregor's, Inc.
 — W & W Distributing Co.
 Nashville — Currey's Wholesale Distributors
 — Electra Distributing Co.
 — Moore-Handley Hardware Co., Inc.

TEXAS

Amarillo — Dulaney's Co., Inc.
 Beaumont — Covington Distributing Corp.
 Corpus Christi — Hayes Radio Supply Co.
 Dallas — Adleta Co.
 — Grabtree's Wholesale Radio Co.
 Denison — Denison Radio Supply
 Ft. Worth — Sutton's Wholesale Electronics
 Houston — Angie Radio & Supply Co.
 — Electro-Mechanical Products Co.
 — Hall, Inc.
 Midland — Henderson-Hoff
 San Antonio — Mission Radio, Inc.
 — Modern Radio Supply
 Tyler — Radio Service Supply Co.

VIRGINIA

Bristol — Bristol Radio Supply Corp.
 Fredericksburg — J & J Appliance Co.
 Lynchburg — Eastern Electric Co.
 Newport News — Noland Co., Inc.
 Norfolk — Radio Parts Distributing Co.
 Richmond — Meridan Electronic Equipment Co.
 Roanoke — Leonard Electronics of
 Roanoke, Inc.
 Winchester — Leonard Electronics of
 Winchester, Inc.

WEST VIRGINIA

Bluefield — Superior Sterling Co.
 Huntington — TV Supply Co.

WISCONSIN

Madison — Superior Radio Co. of Madison
 Milwaukee — Electronic Expeditors Co.
 — Marsh Radio Supply Co.
 Racine — Superior Radio Co.
 Wausau — Electronics, Inc.

The above listing was closed as of November
 10, 1953. Watch for new Westinghouse Dis-
 tributor Appointments in your area.

ET-95046

MAC'S RADIO SERVICE SHOP

By JOHN T. FRYE

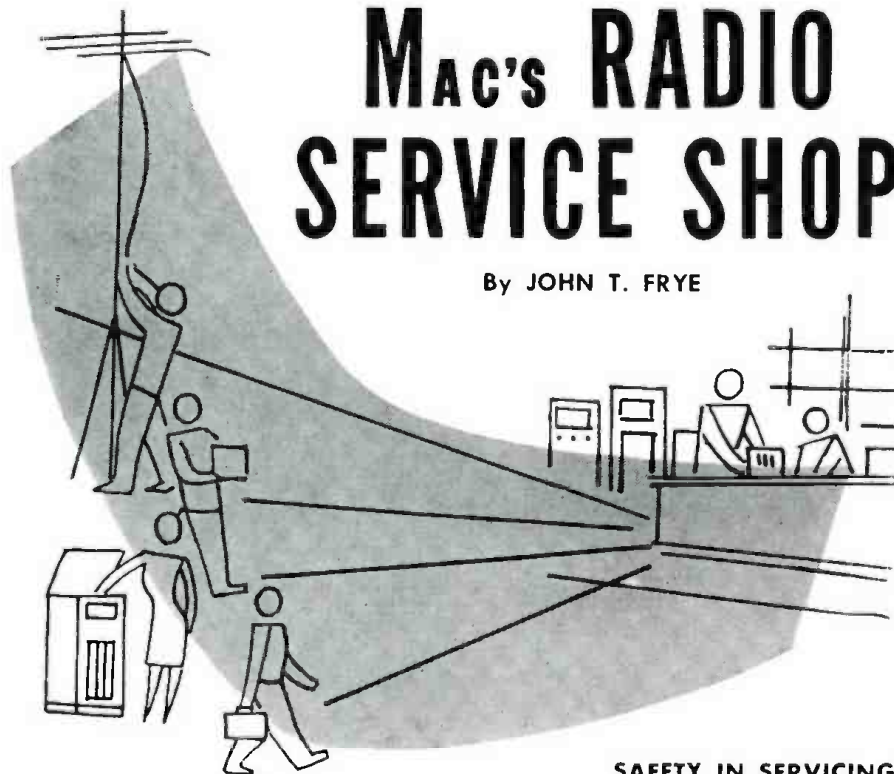

SAFETY IN SERVICING

MAC WAS aligning a receiver in which his assistant, Barney, had just installed new filter condensers. Suddenly he grunted heavily and jumped back from the chassis. Then, as Barney watched guiltily, he pulled the line plug from the socket and gingerly turned the chassis over. "Now there," he said as he jabbed an accusing finger at the wiring beneath the chassis. "is something I *NEVER* want to see you do again."

"What's wrong with that?" Barney asked. "That old can-type condenser has been cut out of the circuit. See, here's where the lead from the insulated case has been cut loose. The positive terminal has been left wired in merely as a convenient tie-point for the new cartridge-type electrolytic."

"And so what happens?" Mac demanded. "The shorted condenser element inside the can conducts the full voltage from the positive lead right to the floating case. To make matters worse, while looking to see what size condenser you would need for replacement, you removed the cardboard covering that was slipped over the can of the electrolytic and failed to replace it. That is why I got a full 300-volt jolt a few minutes ago when my hand brushed against the case of that old electrolytic. The same thing could have happened to a housewife dusting out the chassis when the receiver was turned on; or a little child might have put his hand on the condenser can and received a fatal shock. If this had been a TV chassis, I might have jerked when I was shocked and hit the picture tube with a tool in my hand, causing it to implode. In the future, I want *both* leads of an electrolytic that sticks above the chassis

cut loose, unless the can itself is grounded.

"And while we are talking about such matters, it probably will not hurt to touch on two or three other points. For example, the other day I noticed that you used a new 'outboard' one-megohm resistor to replace one that had gone bad inside the socket of a magic-eye tube. You failed to tape the exposed leads of the resistor, although one of those leads was a full 250 volts d.c. above the chassis. Fortunately I noticed this and taped them up before the set got out of the shop. A good general rule to follow is that no on-top-of-the-chassis point should be left exposed to touch if it carries more than ten volts potential."

"I saw a dandy along that line the other day," Barney remarked. "Someone had replaced the output transformer mounted on the speaker and through thoughtlessness or neglect the 'B-plus' and output-tube-plate lead junctions were left exposed where even a crawling child could easily reach them. That was dangerous."

"Speaking of crawling children, you can't be too careful of line cords," Mac went on. "Quite often these cords will look all right except for a short space just back of the plug, right where the fingers would likely be when the plug is being inserted or removed. The reason, of course, is that the cord at this point takes quite a beating from sweepers, dustmops, and little children. I always try to take a quick gander at the line cord when the customer brings a set in or when I pick it up; and if the line cord looks the least bit suspicious, I suggest right then and there that it be replaced. Few people will turn the suggestion down."

"While we're gabbing about safety, maybe we ought not squander all our solicitude on the customer," Barney suggested. "How's about mentioning a few things that may help the service technician reach a mellow age?"

"At least one technician I know shows promise of becoming mellow, very mellow, long before he becomes ripe," Mac observed, "but your idea has merit. I think we have touched on most shop-safety points at various times in the past, but if these ideas are to do any good, you have to keep harping on them. Anyone who has ever studied how accidents happen knows there is a great difference between knowing that a danger exists and being constantly aware that the danger is present. It is this constant awareness that keeps you from having an accident."

"The voltages we constantly deal with are one of our greatest dangers, aren't they?" Barney asked.

"That's right, and the dangerous part is that familiarity breeds contempt. We are constantly working on receivers having potentials all the way from 100 volts up to fifteen kilovolts or so. Every now and then we get nipped a little without being seriously hurt, and each time this happens we lose a little more respect for the potentially lethal power that lurks in even a lowly a.c.-d.c. set. In fact, there are some pumpkin-headed technicians I know who boast about how they take no precautions against being shocked because they 'can take it.' Their undertaker will be doing the taking one of these days.

"A simple precaution that should be standard procedure in any shop is to plug *all* sets, both a.c.-d.c. and transformer type, into isolation transformers while they are being serviced. Most technicians realize the danger present when working on hot-chassis a.c.-d.c. receivers; but they overlook the fact that quite often lightning will cause the condenser that goes from one side of the line to the chassis of a transformer set to become shorted. Such a set can be a real death-trap, because you do not expect the chassis to be hot.

"Another point I had vividly demonstrated one time is that you should never try to pick up a heavy chassis and move it while the cord is plugged in. I saw a person pick up such a chassis and start to slide it into the cabinet. Suddenly he began to shake all over and to make a peculiar noise. I jerked the cord from the wall socket, and he dropped the chassis to the floor and tottered to a chair. A strong odor of burned flesh was in the room. His fingers, curling beneath the edge of the chassis, had come into contact with the tie-points for the 117-volt line cord. The current froze him so that he could not let go and made his contracting muscles force his fingers tighter and tighter against the searing wires. Grooves were burned into those fingers that took months to heal."

(Continued on page 112)

Depend on Mallory
for
Approved Precision Quality

The sales leader—
proved in every UHF area



Now...

The MALLORY CONVERTER Packs *ALL* Features in Half the Size!

*The new Model 88 has these important Sales Advantages
originated by Mallory:*

Less than half as large . . . measuring only $7\frac{5}{8}$ " wide x $5\frac{9}{16}$ " high x $4\frac{5}{8}$ " deep . . . yet full Mallory quality.

It has linear tracking. Tuning is easier, more exact than ever. No bunching of channels.

The Preselector in the new 88 protects against image interference, oscillator radiation and interference at the IF frequency. It insures better selectivity.

The Mallory 88 Converter adds *all* UHF channels to *any* TV set without sacrificing a single VHF channel.

Design refinements and precision quality of the 88 assure high quality picture definition and easy tuning.

The customer has nothing more to buy, no adjustments to make for additional new channels . . . even if he moves to another area.

Installation is easy. It only takes a few minutes to connect the antenna and power leads from the Converter to the set. It can be done right in the customer's home.

ASK YOUR MALLORY DISTRIBUTOR for complete details of the new, handsome, compact Model 88 Converter. It can be your answer to bigger profits . . . just as all Mallory Converters have been for dealers in areas where UHF is already on the air.

P. R. MALLORY & CO. Inc.
MALLORY

CAPACITORS • CONTROLS • VIBRATORS • SWITCHES • RESISTORS
RECTIFIERS • POWER SUPPLIES • FILTERS • MERCURY BATTERIES
APPROVED PRECISION PRODUCTS

P. R. MALLORY & CO., Inc., INDIANAPOLIS 6, INDIANA

KAY-TOWNES

Announces

*the new
Super*

"KATYS"

(PATENTS PENDING)

Highest Gain

**ALL-CHANNEL VHF ANTENNAS
EVER DESIGNED!**

GUARANTEED

**TO OUT-PERFORM ANY OTHER
ALL-CHANNEL VHF ANTENNA
ON THE MARKET**

Practically every TV Antenna maker in America has made just such statements as these . . . *but, there is a big difference in making these broad claims and then being able to back them up!*

WE CAN! We are prepared to run a **PERFORMANCE TEST** with *anyone . . . anywhere . . . anytime . . .* to prove the vast superiority of the new **SUPER "KATYS"** over all other all-channel VHF antennas . . . regardless of manufacture, design, type or number of bays!

IN FACT, WE WILL POSITIVELY AND ABSOLUTELY GUARANTEE THAT OUR SINGLE-BAY SUPER KATY WILL OUTPERFORM ANY VHF 4-BAY ANTENNA MADE TODAY!

Our 2-Bay SUPER KATY is designed for *extremely difficult* reception areas. It has been tested in many practically impossible locations . . . **AND HAS NEVER FAILED TO BRING IN A PICTURE RATED EITHER "VERY GOOD" OR "EXCELLENT"!**

4½ Years **IN DEVELOPMENT...**

**THE AMAZING SUPER KATY DESIGN MAKES OTHER VHF ALL-CHANNEL ANTENNA DESIGNS AS OBSOLETE AS THE HORSE AND BUGGY!
WE CHALLENGE YOU TO TEST IT . . . ANYWHERE!**

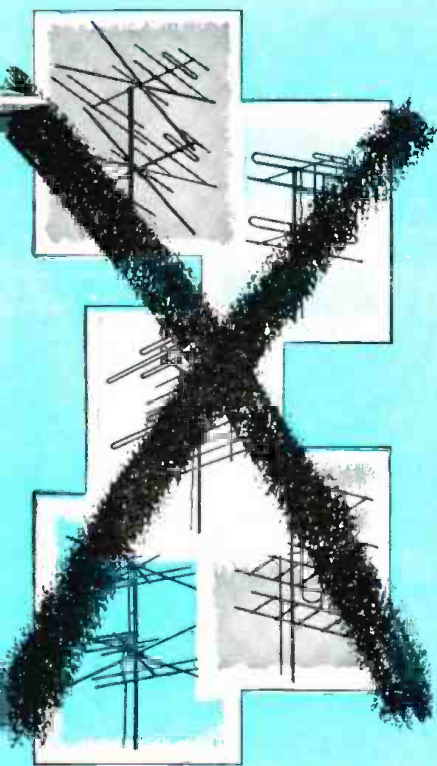

Super
KATY-2
 2-BAY

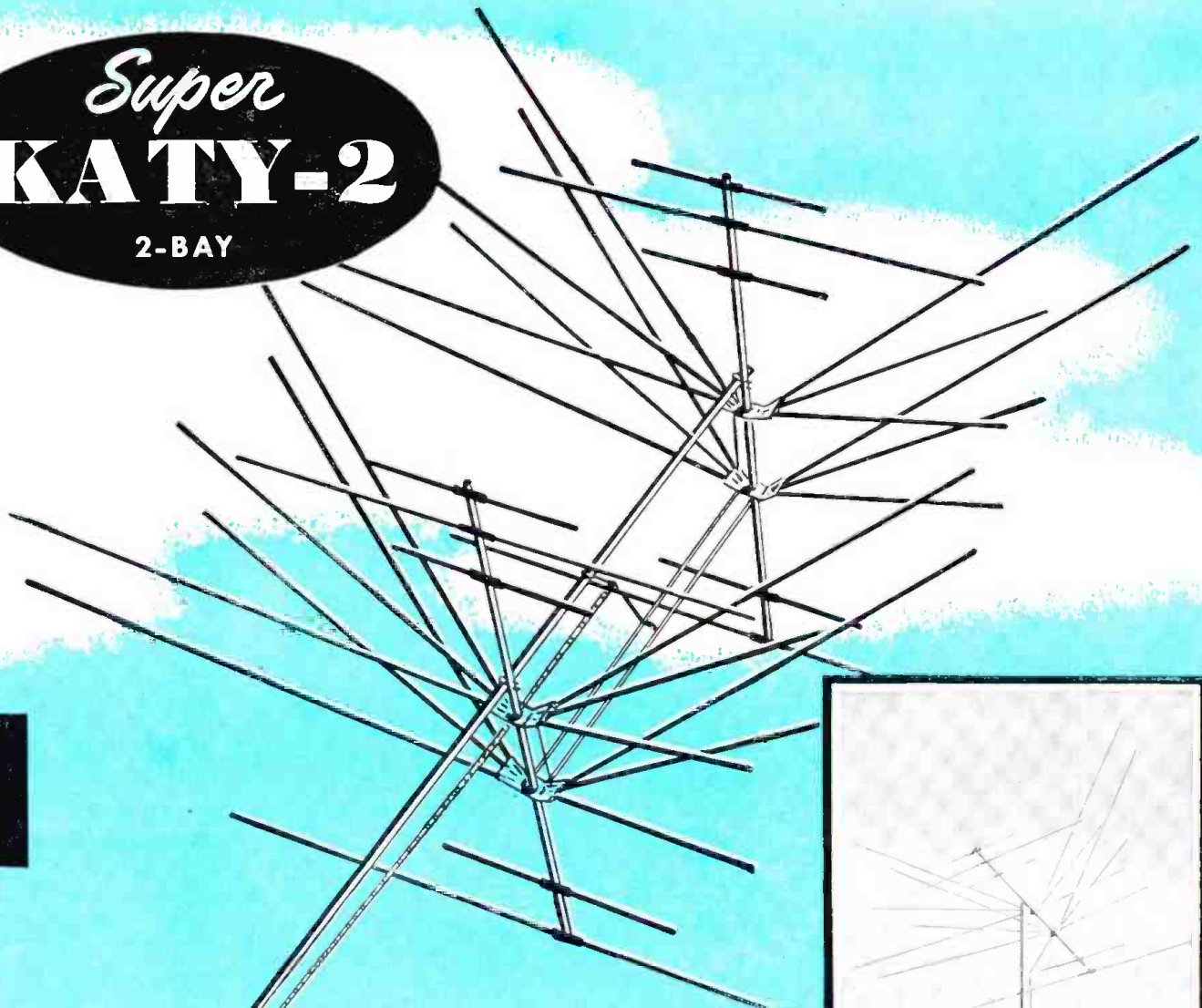

Super
KATY-1
 SINGLE-BAY

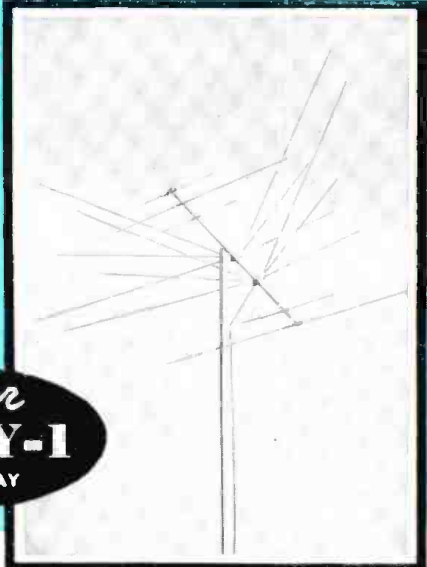

Now **THE WORLD'S FINEST ALL-CHANNEL VHF RECEPTION!**

The SUPER KATY all-channel VHF antennas feature a twin-driven array with a combination of special cut elements for a close 300 OHM impedance across the entire VHF Band. This feature in conjunction with the long, accumulative fan dipoles, with directors and reflectors properly cut and spaced, results in performance never before obtained by any antenna design . . . including our own "BIG JACK", whose design has been so widely "hijacked".

Actual tests show that the Single-Bay KATY-1 will outperform any 10-element Yagi on every channel, 7 through 13 . . . and will perform as well as any 10-element Yagi on every channel, 2 through 6.

	List Price
SUPER KATY-1	\$25.00
<small>Single-Bay</small>	
SUPER KATY-2	\$50.00
<small>2-Bay</small>	

K-T Antennas are sold through selected distributors only . . . write for name of your nearest jobber.

KAY-TOWNES
ANTENNA COMPANY
 ROME, GEORGIA

Recognized leaders in the field of fringe area antenna design

Hi-fi COMPENTROL*

... sweet-sounding
business
builder

This modern tone-blender puts boogie beat or high-pitched notes of operatic sopranos right in their place!



Makes any music sound better! Assures hi-fi reproduction at low-volume levels.

Centralab Compentrol is a combination volume control and Printed Electronic Circuit. It's specially developed for smoother reproduction of apparent bass and treble response on radios, audio amplifiers, phono combinations and TV sets.

You can stake your service reputation on this replacement—it actually improves original tone performance. Unique Centralab design means Compentrol needs no additional amplification... and there's no insertion loss.

*Trademark

Your Centralab distributor has Compentrol in stock, in 1/2 and 1 meg. plain or switch types. See him for your supply and complete information.

Centralab

CENTRALAB,
A Division of Globe-Union Inc.
910-A E. Keefe Ave., Milwaukee 1, Wis.

Please send me additional technical data on Compentrol.

Name.....

Firm.....

Address.....

City..... Zone..... State.....

Phone-Plug Amplifier

(Continued from page 65)

The value of the coupling condenser will have some effect on the frequency response of this amplifier. The input impedance of the CK722 when used as shown with a grounded emitter is in the vicinity of 500 to 1000 ohms. Therefore the capacity of 5 μ fd. which we used can be expected to give good response down to about 100 cycles. If you desire to use a different value of capacity, the lowest frequency at which good gain can be obtained will vary in inverse proportion to the capacity. If you desire to reduce any 60-cycle hum which may exist in the equipment with which the phone-plug amplifier is used, this capacity may be decreased enough to reduce gain at that frequency and thus provide hum attenuation.

In constructing this phone-plug amplifier, it will probably be necessary to cut off the studs inside the phone plug to which the phone cords are usually attached. The actual alterations will

have to be determined by the constructor after he has all components at hand so that he can determine how to arrange and mount them. The jack at the rear of the phone-plug amplifier was made using lucite tubing for insulation, a short length of thin-wall metal tubing of 1/4" inside diameter, and another piece of metal to contact the tip of the phone plug. Another method would be to attach a standard phone jack of the short miniature type to the rear of the phone-plug amplifier. This latter method would provide an easy means for turning off the amplifier if the jack is of the type which closes a third contact when the plug is inserted. Fig. 2B shows the circuit using a jack of this type. Actually in the original circuit of Fig. 2A, the only current drawn from the battery when earphones are not plugged into the rear of the phone-plug amplifier is that through resistor R in series with the base and emitter of the CK722. It is so small that the battery will give practically the same life as that obtained when a switch is included, as shown in Fig. 2B. —30—

A MODULATION PER-CENT INDICATOR

By EDGAR TSCHISCHKE, OA6G

THE new TV and FM tuning indicator tube, the 6AL7GT, is the heart of this little device. Having two indicator plates and the corresponding screens, this tube is ideally suited to this purpose because both halves have the same sensitivity, working with negative voltage on the deflector plates.

Now if we apply the negative voltage developed through the a.v.c. by any station in a given receiver to one of the indicator plates, we obtain a deflection. The increased illumination is controlled by that plate. Now if we apply a corresponding audio voltage to the other deflector plate, an audio voltage which has been amplified and then rectified to obtain a negative value, we have a varying a.v.c. voltage that is in direct relation to the carrier tuned in by the receiver.

The indicator unit can be constructed on a small aluminum chassis so that it can be incorporated into the receiver, if desired. The points to remember are: do not make the leads too long and do not place the 6AL7GT tube too near any magnetic field such as the speaker, filter chokes, or power transformers.

After every part is mounted and the wiring completed, check carefully for errors. If everything is OK we can proceed with the adjustment of the unit.

In cooperation with a friendly ham who has a plate-modulated transmitter and an oscillo-

scope (or other means of checking his percentage of modulation) tune in your receiver and see if his signal is too strong—if it is, shorten or disconnect your antenna but under no circumstances reduce the sensitivity of your receiver as it may then give erroneous readings later on.

Now ask him to modulate his carrier 100 per-cent with a steady note. Very carefully adjust the 1 megohm control until both signals on the screens of the 6AL7GT are equal. This is all there is to adjusting the unit.

One point regarding the construction. The wire that carries the negative voltage developed in the detector (a.v.c.) and the audio signal must be shielded to avoid any hum in the receiver.

With some experience, you can recognize the kind of modulation used; for instance grid modulation (screen), be it clamp or with a transformer, is recognized because with zero per-cent modulation the carrier and audio indicators are low and climb together when modulation is applied. This is also true when class B linear and narrow-band FM are used.

This little indicator is now working fine on a Hallicrafters SX-25 receiver and I am now building another one for my Hammarlund HQ-129X. Good luck to those who build this unit. It is really worth the time and effort.

Schematic of the modulation per-cent indicator for a communications receiver.

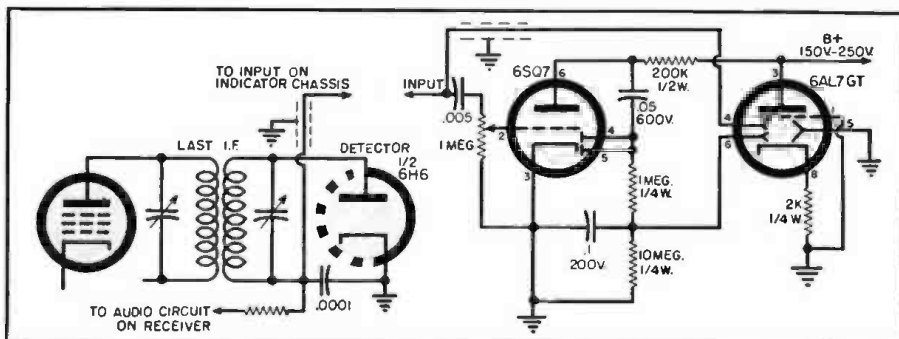

Here's your Opportunity

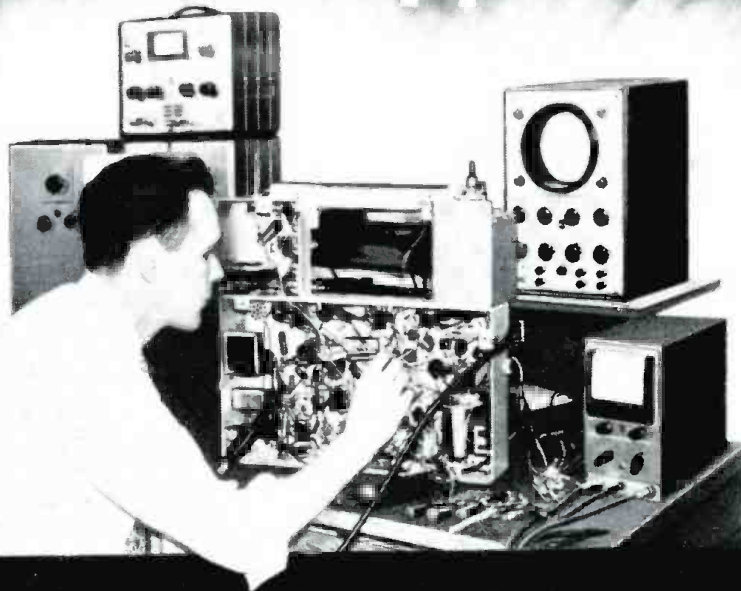

**to prepare for a good job or a business
of your own in TV SERVICING**

ARE YOU SATISFIED with the position you now hold? Do you feel you're worth more money? Are you pleased with yourself, your work, your associates . . . and your future? What does the next year hold for you . . . and the year after that?

Are you content merely to plod along through the best years of your life . . . or do you want to get into more pleasant work . . . hold a well-paid job . . . perhaps establish your own business?

If you are looking for a REAL opportunity . . . If you want to GROW with a GROWING INDUSTRY . . . If you want to grasp the success that should be yours, then we say to you, study TV Servicing.

Everyone knows that Television is the fastest growing industry today. Opportunities are going begging for men who have

the training and ability to grasp them. *Now is the time to start on the road to success in TV Servicing.*

Study at Home in your spare time

The RCA Institutes Home Study Course in TV Servicing is easy to learn. You progress rapidly, step by step, as you learn the procedure of servicing and trouble-shooting TV receivers and installing TV antennas. Hundreds of pictures and diagrams help you understand the how-it-works information and the how-to-do-it techniques.

A Service of

Radio Corporation of America

The RCA Institutes TV Servicing course was written and planned by instructors with years of specialized experience in training men. You get up-to-the-minute information, too, because you study right at the source

of the latest developments in Television. Your lessons are carefully examined and accurately graded by competent teachers who are interested in helping YOU to succeed.

RCA Institutes is licensed by the University of the State of New York . . . an affiliate member of the American Society for Engineering Education . . . approved by leading Radio-Television Service Organizations.

It costs so little to gain so much

RCA Institutes makes it easy for you to take advantage of the big opportunities in TV Servicing. The cost of the TV Servicing Home Study Course has been cut to a minimum. You pay for the course on a pay-as-you-learn unit lesson basis. *No other home study course in TV Servicing offers so much for so little cost to you.*

RCA Institutes conducts a resident school in New York City offering day and evening courses in Radio and TV Servicing, Radio Code and Radio Operating, Radio Broadcasting, Advanced Technology. Write for free catalog on resident courses.



RCA INSTITUTES, INC.
A SERVICE OF RADIO CORPORATION of AMERICA
350 WEST FOURTH STREET, NEW YORK 14, N. Y.

January, 1954

SEND FOR FREE BOOKLET—Mail the coupon—today. Get complete information on the RCA INSTITUTES Home Study Course in Television Servicing. Booklet gives you a general outline of the course by units. See how this practical home study course trains you quickly, easily. Mail coupon in envelope or paste on postal card.

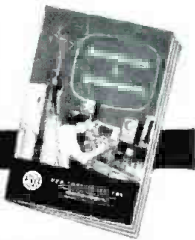

MAIL COUPON NOW!

RCA INSTITUTES, INC., Home Study Dept. RN154
350 West Fourth Street, New York 14, N. Y.

Without obligation on my part, please send me copy of booklet "RCA INSTITUTES Home Study Course in TELEVISION SERVICING." (No salesman will call.)

Name _____ (please print)

Address _____

City _____ Zone _____ State _____

AMPHENOL

EMPHASIS ON

QUALITY

makes antennas 4 ways

Better

Better

PICTURE

VHF or UHF, any television set will present its finest picture with an AMPHENOL antenna. There is an AMPHENOL antenna for every location, and AMPHENOL precision engineering has designed each antenna type to satisfy the most stringent electrical requirements.

Better

PERFORMANCE

AMPHENOL antennas will outlast ordinary antennas in every installation. The use of premium materials and craftsmanship antenna assembly assures set owners of long trouble-free years of efficient performance. Ice storms or high winds are easily weathered by sturdy AMPHENOL antennas.

Better

BUSINESS

The combination of better TV pictures and longer-lasting antenna installations adds up to better business for every dealer or serviceman that sells the quality AMPHENOL line. Customer satisfaction is one sure result of selling AMPHENOL—and is a dealer's best advertisement for future business.

Better

PROFITS

Selling up to quality with AMPHENOL instead of down to price with other antennas means higher profits for every merchandiser. The slightly higher price of an AMPHENOL antenna to the customer gives him the best antenna on the market—and gives you a larger gross and a higher net profit.



AMERICAN PHENOLIC CORPORATION

Chicago 50, Illinois

International Short-Wave

(Continued from page 73)

5.985 at strong level 0530-0600, Home Service relay. **Colombia**—HJKH, 5.070 Sutateña, heard 0600 with good program of music and news in Spanish; has special *English* session Sat. 0530-0600 for listeners in Australia-New Zealand. (Sanderson, Australia) HJCF, "La Voz de Bogota," has been logged around 1830 with recorded music on 5.962, fair level in France. (Mercier) ISWC, London, says the new station "Radio Libertad," 5.974A, heard 1800-2300, is located at Medellin.

Cuba—COCW, *Radio Reporter* (formerly Cadena Roja), Havana, is now operating on 5.045 instead of 6.322, scheduled 0800-2300. COCH, *Radio Internacional*, is now off the air. (WRH) COKG, 8.955, Santiago, 1 kw., lists schedule of 0600-0030. (Roberts, Conn.) *Radio Salas*, 9.030, noted closing 0100. (Kahan, Calif.) COCY seems back on the air on 11.728A, noted around 1315 and at other times. (Ferguson, N. C.; Niblack, Ind., others)

Cyprus—Station officials write that *Sharq-al-Adna* is normally in operation about 12 hours daily on 6.12, 6.17, 6.79, 9.65, 11.72. (Arp, Ohio)

Czechoslovakia—Prague, 9.504, noted signing on *English* 1400, news and commentary followed. (Pearce, England) Heard with *English* for North America 1930-2000 on winter channel of 7.255A. (Bellington, N. Y.)

Dominican Republic—H12A, Santiago de los Caballeros, reported to have moved to 4.840 from 9.680 some time ago, was found recently on 6.044 at 1930 onwards with usual commercial programs in Spanish. (Mercier, France, via *Etersvep*, Sweden)

Dutch New Guinea—R.O.N.G., 5.045, Hollandia, heard 0500 with news and music. (Sanderson, Australia) Has *English* daily now 0500-0530 for Australia.

Ecuador—HCJB, 11.915, noted 2015-2030 with music, good level. (Middleton, O.)

Egypt—Cairo, 9.475, is widely noted daily 1320-1700 parallel 11.815, news 1330. (Washington, N. J.; Zahner, Md., others) Has been heard on 17.725 around 0800-0900 and later in *English*, French, and Asiatic languages in test transmission over the new high-powered transmitter beamed to Far East. (Ferguson, N. C.; Japanese Short Wave Club)

El Salvador—*Radio Panamericana*, 11.95, is heard 1800-2000. (Gay, Calif.)

England—Some weeks ago, the BBC was heard on 11.800 (announced 9.600 as parallel) with test transmission 0830-0900 to British North Greenland Expedition; asked for reports from expedition members; excellent strength in Iceland. (Brien)

Ethiopia—*Radio Addis Ababa*, 15.050AV, appears to have *English* 1315 on Sat. only now; closes 1430.

Fiji Islands—ZJV3, 3.980, Suva, noted 0515 at good level with music, news. (Sanderson, Australia) Heard in Virginia 0315-0530 closedown, usually at weak level.

France—Paris now has *English* for Britain on 7.240 at 0245, and Sun. also 0800-0900 on that channel. (Cody, Ireland; Patrick, Catch, England)

French Equatorial Africa—*Radio A. E. F.*, 9.96, Brazzaville, noted 1215 with songs in French. (Pearce, England) *Radio Brazzaville*, 11.97, noted with news 0015-0030. (Jannis, S. C.) Is weak on 9.44 at 1300 in French. (Kroll, N. Y.) This channel is at good level 1930. (Kirby, Mo.) Is good level with news 1745-1800 on both 9.44, 11.97.

Germany—Baden-Baden, 6.320, is on the air 0000-1800. (ISWC, London) The Overseas Service, Cologne, is on winter schedule of 0530-0830, 11.795; 0930-1230, 1300-1600, 1700-2000, 7.290; 2030-2330 (to North America), 5.980, 7.290. (Radio Sweden, others) RIAS, 6.005A, Berlin, noted at strong level in German 0130. (Cox, Dela.) AFN, 5.470, Bayreuth, heard 1330 with station call, good level but QRM'd. *Radio Frankfurt*, 6.189, noted 1830 with dance music, excellent level in Britain. (Catch)

Gold Coast—Accra now uses 4.915, 5 kw., and 6.200, 1.3 kw., with *English* 0700-0800, 0930-1045, 1130-1300; vernacular 0630-0700, 1045-1130. (WRH)

Greece—Forces Station, 7.420A, signs on daily 2330 with Greek National Anthem; on Sat. 0100 has church services.

Guadeloupe—Basse-Terre is noted on its *new* channel 6.067A at fair level to 2000 closedown, rebroadcasting a program from the French Home Service, Paris. (Mercier, France, via *Etersvep*, Sweden. (Niblack, Ind.)

Haiti—*Radio Commerce* uses both 9.485 and 6.140 now 1600-1930. (Boyce, N. J.) Noted on 9.485 around 0900-1130. (Zerosh, Pa.) 4VRW, 10.074A, has *English* ("Your Music Caravan") Thur. 2130-2215. (West Va., others) Noted announcements in French, Spanish, *English* 1800. (Hanson, Texas) 4VB, 6.143, Port-au-Prince, noted to close 2258 when announced in French and played Anthem; *measured*. (Ferguson, N. C.) 4VEH is scheduled 0600-0900 Mon., Tues., Wed., Fri.; 0600-0930 Sat.; 0600-0900, 1630-2140 Sun. all on 9.69; *by this time should have a Monday "evening" broadcast* on 9.675 to include a repeat of "Listener's Post," heard regularly Sat. 0605-0625.

Holland—*Radio Nederland* has *English weekdays* 0445-0525 to Australia. New Zealand, Pacific Area, 15.425, 15.22, 11.73, 5.98; 1100-1140 to South Asia and Africa, 15.425, 9.59, 7.21, 5.98; 1645-1725 to Europe and North America 9.59, 6.025, 5.98; 2130-2210 to North America, 9.59, 6.025. (Matherly, O.; Smits, Minn.; Campbell, Pa.) Noted on 17.775 around 1130 with *English*. (Hill, Fla.)

Hungary—Budapest is using 6.248 again this *winter* instead of 11.91, heard with *English* from 1930. (Bellington, N. Y.) Is good level in *English* 1715-1745 on 9.833. (Kirby, Mo.) And 1930-2000. (Grace, Conn.)

India—Madras, 7.260, heard 0610 with *English* program of news, music; VUD, 7.210, Delhi, noted 0715 with weather reports, local news, music; heard on 15.290 at 0230 with news and music. (Sanderson, Australia)

Indo-China (Vietnam)—*Radio France-Asie*, 11.935, Saigon, noted 1012 with varied recordings announced in *English* by woman; 1100 news in French; closed 1121 with "La Marseillaise." (Pearce, England) Heard on 11.935 at 2045 with news and music; on 15.420 at 0430 with news and music; on 6.116 at 0600 noted military transmitter in French news, music. (Sanderson, Australia) Lists schedule for *English* as 7.230 at 1830-1900; 11.935, 2030-2045; 11.935, 0900-1115 (Harris, Mich.) "Voice of Vietnam," 7.288, heard 0700 with French program of news, music; Hanoi, 7.405, noted 0600 with French news, music. (Sanderson) Saigon heard on 9.620 in Vietnamese 0619, weak level. (Cox, Dela.) RFA noted opening 1100 in *English* to Europe on 9.757A, weak level in Calif. (Gay)

Israel—Tel-Aviv, 9.010A, noted with news 1515. (Parsons, Pa.) Heard with "Voice of Zion" session 1615-1700 closedown. (Parsons, Va.; Hyson, Md.)

Italy—Rome noted in *English* and Italian 0445 onwards on 17.800; to Great Britain from 1230 on 9.63, 11.81. (Pearce, England) According to announcement *Radio Roma* has *new* QRA of Box 320, Rome. (Bellington, N. Y.) *New* schedules to North America include a special program in Italian 1730-1810 on 11.81, 9.71, 9.57, 7.29, 6.21; 1815-1835 *English* to USA on 9.57, 7.29; 1835-1855 has French to Canada on same channels; 1900-2025, 2055-2110 has Italian on 9.78, 9.71, 9.57, 7.29, 6.21; has news in Spanish for Mexico and Central America 2030-2050 on 9.78, 9.71, 6.21, and at same time there is *English* for USA on 9.57, 7.29. (Boyce, N. J.)

Jamaica—Current frequency of *Radio Jamaica* is 3.360. (WRH, others) Noted to 2300 at fair level, but at times has heavy QRM from a Venezuela outlet and some CWQRM. (Hill, Mass.) Has news 1800. (Cox, Dela.)

Japan—AFRS, JKL2, 9.605, Tokyo, noted 0217 with popular music. (Cox, Dela.)

Lebanon—Beirut, 8.036, still has *English* 1000-1100. (Pearce, England) Heard 1620 with French program of news, music. (Sanderson, Australia)

Libya—Forces Broadcasting Station, believed at Benghazi, noted on 4.785 closing 1601 in *English*; bad CWQRM. (Pearce, England)

Mexico—XEBT, 9.625, noted using *English* around 1835, and again at 2235 asking for reception reports; latter was on Sat. (Bellington, N. Y.) XESC, 15.205A, noted 1800-1900 in Spanish. (Kahan, Calif.)

(Continued on page 142)

antennas by **AMPHENOL**

UHF/VHF

UHF



STACKED-V
114-059



YAGI
114-054

VHF



-INLINE*

*REISSUE U.S.
PAT. NO. 23.273
114-005



BO-TY
114-065

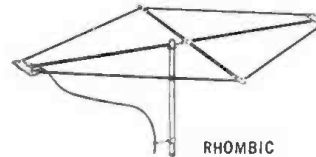

RHOMBIC
114-060

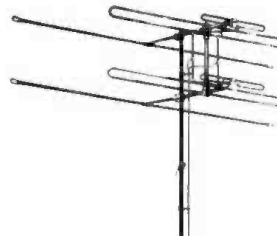

STACKED ARRAY
114-302

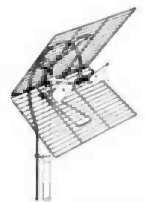

CORNER REFLECTOR
114-058

for a complete line of quality
tv antennas, look to

AMPHENOL

AMERICAN PHENOLIC CORPORATION

Chicago 50, Illinois



Heathkit IMPEDANCE BRIDGE KIT

MODEL IB-2

\$59⁵⁰

SHIPPING WT.
15 LBS.

Another new, outstanding instrument design so typically characteristic of Heathkit operation in producing high quality instrument kits at the lowest possible price. A new, improved model Impedance Bridge kit featuring modern cabinet styling, with slanted panel for convenience of operation and interpretation of scales at a \$10.00 price reduction over the preceding model. Built-in adjustable phase shift oscillator and amplifier with all tubes of the battery operated type completely eliminates warm-up time. The instrument is entirely AC line operated. No bothersome battery replacements.

The Heathkit IB-2 Impedance Bridge Kit actually represents four instruments in one compact unit. The Wheatstone Bridge for resistance measurements, the Capacity Comparison Bridge for capacity measurements, Maxwell Bridge for low Q, and Hay Bridge for high Q inductance measurements. Read Q, D, DQ all on one dial thereby eliminating possible confusion due to the incorrect dial reference or adjustment. Only one set of instrument terminals nec-

essary for any measurement function. Panel provisions provided for external generator use.

A newly designed two section CRL dial provides ten separate "units" switch settings with an accuracy of .5%. Fractions of units are read on a continuously variable calibrated wire-wound control. A special minimum capacity, shielded, balanced impedance matching transformer between the generator and the bridge. The correct impedance match is automatically switch selected to provide constant load operation of the generator circuit. The instrument uses 1/2% precision resistors and condensers in all measurement circuits.

The new Heathkit IB-2 provides outstanding design features not found in any other kit instrument. The single low price includes the power supply, generator, and amplifier stages. No need to purchase separate instrument accessories in order to obtain the type of operation desired.

Features

- Simpson 100-0-100 microampere meter.
- Completely AC operated.
- Built-in phase shift generator and amplifier.
- Battery type tubes, no warm-up required.
- Newly designed two section CRL dial.
- Single knob D, Q, and DQ functions.
- Special impedance matching transformer.
- New modern cabinet styling.
- 1/2% precision resistors and silver mica condensers.

Heathkit AUDIO WATTMETER KIT

MODEL AW-1

\$29⁵⁰

SHIPPING WT.
6 LBS.

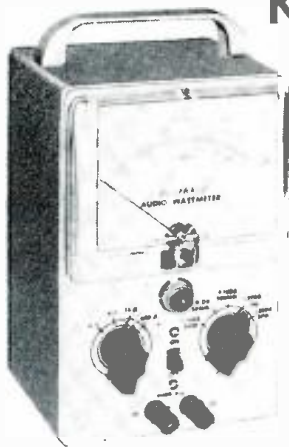

A new Heathkit design for the audio engineer, serious hi fi enthusiast, recording studio, or broadcast station; the Heathkit Audio Wattmeter Kit. This specialized instrument instantly indicates the output level of the equipment under test without requiring the use of external load resistors. All readings are taken directly from the calibrated scales of a 4 1/2" 200 microampere Simpson meter.

The Heathkit Audio Wattmeter features five full scale power measurement ranges from 5 milliwatts up to 50 watts with db ranges of -15 db to +48 db. The instrument has a power measurement rating of 25 watts continuous and 50 watts maximum for intermittent operation. Non-inductive resistance load impedances of 4, 8, 16, and 600 ohms are provided through a panel impedance selector switch. Frequency effect is negligible from 10 cycles to 250 kc. A conventional VTVM circuit utilizes a 12AU7 twin triode tube. The meter bridge circuit uses four germanium diodes for good linearity.

With the Heathkit AW-1 desired information can be obtained instantly and conveniently without bothering with the irksome setups and calculations usually required. Useful for power curve measurements, frequency response checks, monitoring indicator, etc. Convenient calibration directly from 110 volt AC line source. This new instrument will help to supply the answers to your audio operating or power output problems.

Heathkit LABORATORY GENERATOR KIT

MODEL LG-1

\$39⁵⁰

SHIP. WT.
16 LBS.



Another welcome new addition to the popular line of Heathkit instruments, the Heathkit Laboratory Generator. Specifically designed for flexibility of operation, accuracy and versatility beyond the performance level provided by the conventional service type generator. Frequency coverage of the Colpitts oscillator is 150kc to 30mc in five convenient ranges with provisions for internal or external modulation up to 50%, and .1 volt RF output throughout the frequency range. Panel mounted 200 microampere Simpson meter for RF "set reference level" to provide relative indication of RF output. Individually shielded oscillator and shielded variable and step attenuator provide flexible control of RF output.

The circuit features a 6AF4 high frequency oscillator, a 6AV5 amplifier with grid modulation, 12AU7 400 cycle oscillator and modulator, OB2 voltage regulator tube, and a selenium rectifier for the transformer operated power supply. The smart professional instrument appearance and over-all flexibility of operation will prove a decided asset to any industrial or educational laboratory. The Heathkit Laboratory Generator sets a new level of operation, far superior to any instrument in this price classification.

HEATH COMPANY • Benton Harbor 15, Mich.

CHECK THESE *Features*

- ✓ New 5U1 CR tube
- ✓ Re-trace blanking
- ✓ Voltage regulation
- ✓ Extended band width
- ✓ Peak-to-peak calibrating provisions
- ✓ Good square wave response
- ✓ Astigmatism control
- ✓ New heavy duty shielded power transformer

NEW 5" *Heathkit*
OSCILLOSCOPE
KIT
 MODEL O-9
\$59⁵⁰
 SHIPPING
 WT. 28 LBS.



Announcing the latest addition to a brilliant series of Heathkit Oscilloscopes, the new Model O-9. This outstanding instrument incorporates all of the features developed and proven in the production of well over 50,000 kits, in addition to a host of many new design features for truly outstanding performance. This new scope features a brand new (no surplus) commercially available 5U1 cathode ray tube for fine focusing, high intensity, and freedom from halation. The 5" CR tube is the standard size for design and industrial laboratories, development engineers, and service men; the only size CR tube offering a wide range of types, colors, phosphors, and persistence. The answer to good oscilloscope performance lies in improved basic design and operating characteristics, and not in the use of larger CR tubes.

VERTICAL AMPLIFIER — New extended band width vertical amplifier with sensitivity of .025 volts per inch, down 3 db at 2 mc, down only 5 1/2 db at 3 mc. Three step vertical input attenuator, quality ceramic variable capacitors for proper input compensation, provisions for calibrated 1 volt peak-to-peak reference with calibrated screen for the direct reading of TV pulses.

HORIZONTAL AMPLIFIER

— New input selector switch provides choice of horizontal input, 60 cycle sweep input, line sync, internal sync and external sync. Terminal board for easy access to CR deflection plates and Z axis input. New blanking amplifier for complete retrace blanking and new phasing control.

POWER SUPPLY — New High voltage power supply and filtering circuit for really fine hairline focusing. New heavy duty power transformer with adequate operating reserve. Voltage regulated supply for both vertical and horizontal amplifiers for absolutely rock steady traces and complete freedom from bounce and jitter due to line variations.

The acid test of any oscilloscope operation is the ability to reproduce high frequency square waves and the new Heathkit O-9 will faithfully reproduce square waves up to 500 kc. This is the ideal all-round, general purpose oscilloscope for educational and industrial use, radio and TV servicing and any other type of work requiring the instantaneous reproduction and observation of actual wave forms and other electrical phenomena.



NO. 342
\$3⁵⁰ SHIP. WT.
 1 LB.

Heathkit **LOW CAPACITY PROBE KIT**

Oscilloscope investigation of high frequency, high impedance, or broad bandwidth circuits encountered in television work requires the use of a low capacity probe to prevent loss of gain, distortion, or false service information. The Heathkit Low Capacity Probe features a variable capacitor to provide the necessary degree of instrument impedance matching. New probe styling with bright polished aluminum housing and polystyrene probe ends.



NO. 337-B
\$3⁵⁰
 SHIP. WT. 1 LB.

Heathkit **SCOPE DEMODULATOR PROBE KIT**

In applications such as trouble shooting or aligning TV, RF, IF, and video stages, the frequency ranges encountered require demodulation of signals before oscilloscope presentation. The newly-styled Heathkit Demodulator Probe in polished aluminum housing will fulfill this function and readily prove its value as an oscilloscope service accessory. Detailed assembly sheet provided, including instructions for probe operation.

Heathkit **VOLTAGE CALIBRATOR KIT**

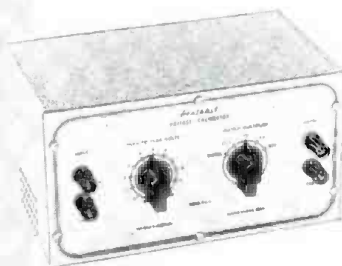

MODEL VC-2
\$11⁵⁰
 SHIPPING WT.
 4 LBS.

The Heathkit Voltage Calibrator provides a convenient method of making peak-to-peak voltage measurements with an oscilloscope by establishing a relationship on a comparison basis between the amplitude of an unknown wave shape and the known output of the voltage calibrator. Peak-to-peak voltage values are read directly on the calibrated panel scales. To offset line voltage supply irregularities, the instrument features a voltage regulator tube.

With the Heathkit Voltage Calibrator, it is possible to measure all types of complex wave forms within a voltage range of .01 to 100 volts peak-to-peak. A convenient "signal" position on the panel switch bypasses the calibrator completely and the signal is applied to the oscilloscope input thereby eliminating the necessity for transferring test leads.

Heathkit **ELECTRONIC SWITCH KIT**



MODEL S-2
\$23⁵⁰
 SHIP. WT. 11 LBS.

The basic function of the Heathkit S-2 Electronic Switch Kit is to permit simultaneous oscilloscope observation of two separate traces which can be either separated or superimposed for individual study. A typical example would be observation of a signal as it appears at both the input and output stages of an amplifier. It will also serve as a square wave generator over the range of switching frequencies, often providing the necessary wave form response information without incurring the expense of an additional instrument.

Continuously variable switching rates in three ranges from less than 10 cps to over 2,000 cps. Individual controls for each input channel and a positioning control. The five tube transformer operated circuit utilizes two 6SJ7, two 6SN7, and one 6X5 tubes. Buy this kit and enjoy increased versatility of operation from your oscilloscope.

HEATH COMPANY • Benton Harbor 15, Mich.



Heathkit VACUUM TUBE VOLTMETER KIT

MODEL V-6

\$24⁵⁰

SHIPPING WT. 6 LBS.

The beautiful Heathkit Model V-6 VTVM, the world's largest selling kit instrument, now offers many outstanding new features in addition to retaining all of the refinements developed and proven in the production of over 100,000 VTVM's. This is the basic measuring instrument for every branch of electronics. Easily meets all requirements for accuracy, stability, sensitivity, convenience of ranges, meter readability, and modern styling. It will accurately measure DC voltages, AC voltages, offers tremendous ohmmeter range coverage, and a complete db scale for a total of 35 meter ranges.

New 1½ volt full scale low range provides well over 2¼" of scale length per volt. Upper DC scale limit 1,500 volts. DC ranges 0-1.5, 5, 15, 50, 150, 500, 1,500 volts full scale. AC ranges 0-1.5, 5, 15, 50, 150, 500, 1,500 (1,000 volts maximum). Seven ohm-

meter ranges from .1 ohm to 1,000 megohms. For added convenience a DC polarity reversing switch and a center scale zero adjustment for FM alignment.

The smartly styled, compact, sturdy, formed aluminum cabinet is finished in an attractive gray crackle exterior. The beautiful two-color, durable, infra-red, baked enamel panel further adds to the over-all professional appearance.

Top quality components used throughout. 1% precision resistors — silver contact range and selector switches — selenium rectifier — transformer operated power supply. Individual calibration on both AC and DC for maximum accuracy. DB scale printed in red for easy identification, all other scales a sharp, crisp black for easy reading. A variety of accessory probes shown on this page still add further to over-all instrument usefulness.

Features

- ✓ New 1½ volt full scale low range
- ✓ 1,500 volt upper limit DC range
- ✓ Increased accuracy through 50% greater scale coverage
- ✓ High impedance 11 megohm input
- ✓ Center scale zero adjust
- ✓ Polarity reversal switch
- ✓ 1% precision resistors
- ✓ Clearly marked db scales

Heathkit 30,000 VOLT DC PROBE KIT

For TV service work or any similar application where the measurement of high DC voltage is required, the Heathkit Model 336 High Voltage Probe Kit will prove invaluable. A precision multiplier resistor mounted inside the two-color, sleek, plastic probe body provides a multiplication factor of 100 on the DC ranges of the Heathkit 11 megohm VTVM. The entire kit includes precision resistor, two-color plastic probe, tip connector spring, test lead, phone plug panel connector, and complete assembly instructions.



No. 336

\$4⁵⁰

SHIP. WT.
2 LBS.

Heathkit AC VACUUM TUBE VOLTMETER KIT

MODEL AV-2

\$29⁵⁰

SHIPPING WT.
5 LBS.

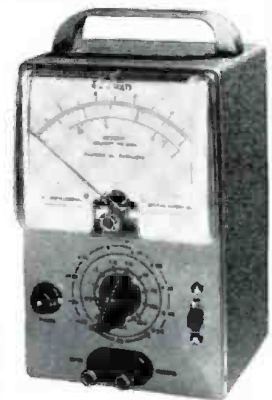

The new Heathkit AC VTVM that makes possible those sensitive AC measurements required by laboratories, audio enthusiasts, and experimenters. Especially useful for hum investigation, sensitive null detection, phono pick-up output measure-

ments, making frequency response runs, gain measurements, ripple voltage checks, etc. Low level measurements are easy to make because of the complete voltage coverage of the instrument and the one knob operation.

The large 200 microampere Simpson meter has clearly marked and easy to read meter scales. Ten voltage ranges covering from .01 rms full scale to 300 volts rms full scale, with frequency response ± 1 db from 20 cycles to 50,000 cycles. Instrument input impedance 1 megohm, ten db ranges from -52 db to +52 db. For stability and good linearity characteristics the meter bridge circuit features 4 germanium diodes. Attractive instrument styling, a companion piece for the popular Heathkit VTVM and the new AW-1 Audio Wattmeter.

No. 338-B

Heathkit PEAK-TO-PEAK PROBE KIT



\$5⁵⁰

SHIP. WT. 2 LBS.

Now read peak-to-peak voltages on the DC scales of the Heathkit 11 megohm VTVM. Readings can be directly made from the VTVM scale without involved calculations. Measurements over the frequency range of 5 kc to 5 mc. Use this probe to extend the usefulness of your VTVM in radio and TV service work. The Peak-to-Peak Probe Kit features the new polished aluminum housing with two-color polystyrene probe ends. Detailed assembly sheet including instructions for probe operation.

Heathkit RF PROBE KIT

The Heathkit RF Probe used in conjunction with any 11 megohm VTVM will permit RF measurements up to 250 mc, ± 10%. A useful, convenient accessory for those occasions when RF measurements are desired. The RF probe body is housed in the new, smartly-styled polished aluminum probe body featuring two-color polystyrene probe ends and a low capacity flexible shielded test lead. The kit is complete with all necessary material and a detailed assembly sheet as well as instructions for probe operation.



No. 309-B

\$3⁵⁰

SHIP. WT. 2 LBS.

HEATH COMPANY • Benton Harbor 15, Mich.

CHECK THESE *Features*

- ✓ 20,000 ohms per volt DC sensitivity, 5,000 ohms per volt on AC
- ✓ Polarity reversal switch
- ✓ 1% precision multiplier resistors
- ✓ 50 microampere 4½" Simpson meter
- ✓ Meter ranges for service convenience
- ✓ New resistor ring-switch assembly
- ✓ Total of 35 meter ranges
- ✓ New Modern cabinet styling

NEW *Heathkit*
MULTIMETER
KIT
 MODEL MM-1
\$26⁵⁰
 SHIPPING WT. 6 LBS.



The most important Heathkit announcement of the year, the new 20,000 ohms per volt Heathkit Multimeter, Model MM-1. The universal service measuring instrument, accurate, sensitive, portable, and completely independent of AC line supply. Particularly designed for service use incorporating many desirable features for the convenience of the service man. Full 20,000 ohms per volt sensitivity on DC ranges — 5,000 ohms per volt sensitivity on AC — polarity reversal switch, no bothersome transferring of test leads — 1% precision multiplier resistors — large 4½" recessed non-glare 50 microampere Simpson meter — conveniently slanted control panel — recessed safety type banana jacks — standard universally available batteries — rugged practical sized cabinet with plastic carrying handle, and a total of 35 calibrated meter ranges.

RANGES

Voltage ranges selected entirely for service convenience. For example 1½ volt full scale low range for measuring portable radio filament voltages, bias voltages, etc., 150 volt full scale range for AC-DC service work, 500 volt full scale range for conventional transformer operated power supply systems. Complete voltage ranges AC and DC, 0-1.5—5—50—150—500—1,500—5,000 volts. DC current ranges, 0-150 microamperes—15 milliamperes—150 milliamperes—500 milliamperes—15 amperes. Resistance measurements from .2 ohms to 20 meg-

ohms x 1 x 1,000 x 10,000.
 DB coverage from -10 db to +65 db.

CONSTRUCTION

Entirely new design permits assembly, mounting and wiring of precision resistors on a ring-switch assembly unit. The major portion of instrument wiring is completed before mounting the ring-switch assembly to the panel. No calibration procedure is required, all precision resistors readily accessible in event of replacement.

CABINET

Strikingly modern cabinet styling featuring two piece construction, durable black Bakelite cabinet, with easy to read panel designations. Cabinet size 5½" wide x 4" deep x 7½" high. Good cabinet physical stability when operated in vertical position.

The Heathkit MM-1 represents a terrific instrument value for a high quality 20,000 ohms per volt unit using all 1% deposited carbon type precision resistors. Here is quality, performance, functional design, and attractive appearance, all combined in one low priced package.

Heathkit
BATTERY TESTER KIT



MODEL BT-1
\$8⁵⁰
 SHIP. WT.
 2 LBS.

The Heathkit Battery Tester measures all types of dry batteries between 1½ volts and 150 volts under actual load conditions. Readings are made directly on a three color Good-Weak-Replace scale. Operation is extremely simple and merely requires that the test leads be connected to the battery under test. Only one control to adjust in addition to a panel switch for "A" or "B" battery types. The Heathkit Battery Tester features compact assembly, accurate meter movement, and a three deck wire-wound control, all mounted in a portable rugged plastic cabinet. Checks portable radio batteries, hearing aid batteries, lantern batteries, etc.

Heathkit
HANDITESTER KIT



MODEL M-1
\$14⁵⁰
 SHIPPING WT.
 3 LBS.

The Heathkit Model M-1 Handitester readily fulfills major requirements for a compact, portable volt ohm milliammeter. Despite its compact size, the Handitester is packed with every desirable feature required in an instrument of this type. AC or DC voltage ranges full scale, 0-10—30—300—1,000—5,000 volts. Two ohmmeter ranges, 0-3,000 and 0-300,000. Two DC current measurement ranges, 0-10 milliamperes and 0-100 milliamperes. The instrument uses a Simpson 400 microampere meter movement, which is shunted with resistors to provide a uniform 1 milliamper load on both AC and DC ranges. Special type, easily accessible, battery mounting bracket — 1% deposited carbon type precision resistors — hearing aid type ohms adjust control. The Handitester is easily assembled from complete instructions and pictorial diagrams. Necessary test leads are included in the price of this popular kit.

HEATH COMPANY • Benton Harbor 15, Mich.



New *Heathkit* 12 Volt BATTERY ELIMINATOR KIT

MODEL BE-4

\$31⁵⁰

SHIPPING WT.
18 LBS.

CHECK THESE *Features*

- ✓ Either 6 or 12 volt operation.
- ✓ Continuously variable voltage output
- ✓ Constant ammeter and voltmeter monitoring
- ✓ Automatic overload relay — self-resetting
- ✓ Two 10,000 mf condensers
- ✓ New 18 disc split type heavy duty rectifier unit
- ✓ Fuse protection

Here is the new Heathkit Battery Eliminator necessary for modern, up-to-date operation of your service shop. The Heathkit Model BE-4 furnishes either 6 volts or 12 volts output which can be selected at the flick of a panel switch. Use the BE-4 to service the new 12 volt car radios in addition to the conventional 6 volt radios.

This new Battery Eliminator provides two continuously variable output ranges, 0-8 volts DC at 10 amperes continuously, or 15 amperes maximum intermittent; 0-16 volts DC at 5 amperes continuously or 7.5 amperes maximum intermittent. The output voltage is clean and well filtered as the circuit uses two 10,000 mf condensers. The continuously variable voltage output feature is a definite aid in determining the starting point of vibrators, the voltage operating range of oscillator circuits, etc. Panel mounted meters constantly monitor voltage and cur-

rent output and will quickly indicate the presence of a major circuit fault in the equipment under test. The power transformer primary winding is fuse protected and for additional safety an automatic relay of the self-resetting type is incorporated in the DC output circuit. The heavy duty rectifier is a split type 18 plate magnesium copper sulfide unit used either as a full wave rectifier or voltage doubler according to the position of the panel range switch.

Here is the ideal battery eliminator for all of your service problems and as an additional feature, it can also be used as a battery charger. Another new application for the Heathkit Battery Eliminator is a variable source of DC filament supply in audio development and research. More than adequate variable voltage and current range for normal applications.

Heathkit VIBRATOR TESTER KIT

Your repair time is valuable, and service use of the Heathkit Vibrator Tester will save you many hours of work. This tester will instantly tell you the condition of the vibrator being checked. Checks vibrators for proper starting and the easy to read meter indicates quality of output on a large Bad-?-Good scale. The Heathkit VT-1 checks both interrupter and self rectifier types of vibrators. Five different sockets for checking hundreds of vibrator types.

The Heathkit Vibrator Tester operates from any battery eliminator capable of delivering continuously variable voltage from 4 to 6 volts DC at 4 amperes. The new Heathkit Model BE-4 Battery Eliminator would be an ideal source of supply.

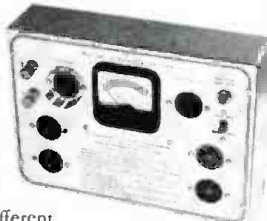

MODEL VT-1

\$14⁵⁰

SHIPPING WT.
6 LBS.

NEW *Heathkit* VARIABLE VOLTAGE ISOLATION TRANSFORMER KIT

The new Heathkit Isolation Transformer Kit provides line isolation for AC-DC radios (not an auto transformer), thereby eliminating shock hazard, hum problems, alignment difficulties, etc. The output voltage is variable from 90 to 130 volts AC and is constantly monitored by a panel mounted AC volt meter. Use it to increase AC supply voltage in order to induce breakdown of faulty components in circuits thereby saving service time. Use it also to simulate varying line voltage conditions and to determine the line voltage level at which oscillator circuits cease functioning, particularly in three-way portable radios. Rated at 100 watts continuous operation and up to 200 watts maximum intermittent operation. A useful radio and TV service tool.



MODEL IT-1

\$16⁵⁰

SHIP. WT. 9 LBS.

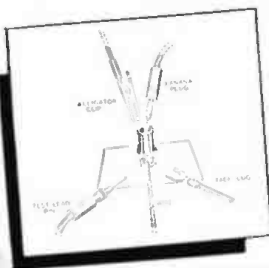

Heathkit BINDING POST

Binding post kit now available so that standardization of all instrument connectors is possible. This new, five-way binding post will accommodate an alligator clip, banana plug, test lead pin, spade lug, or hook-up wire. Sold in units of 20 binding post assemblies. Each assembly includes binding post, flat and shoulder fiber washers, solder lug, and nut. 120 pieces in all. Kit 362, \$4.00.



Heathkit TECHNICAL APPLICATION BULLETINS

TECHNICAL APPLICATION BULLETINS

An exclusive Heathkit service. Technical application bulletins prepared by recognized instrument authorities outlining various combinations of instrument applications. Available now with 40 four-page illustrated bulletins and an attractive flexible loose-leaf binder. Only \$2.00. (No c.o.d. on this item, please.)

HEATH COMPANY • Benton Harbor 15, Mich.

CHECK THESE *Features*

- ✓ INCREDUCTOR controllable inductor sweep
- ✓ TV and IF sweep deviation 12-30 mc
- ✓ 4 mc- 220 mc continuous frequency coverage
- ✓ Oscillator operation entirely on fundamentals
- ✓ Output in excess of 100,000 microvolts
- ✓ Automatic amplitude circuit
- ✓ Voltage regulation
- ✓ Simplified operation

NEW *Heathkit*
**TV ALIGNMENT
GENERATOR
KIT**

MODEL TS-3

\$44.50

SHIPPING WEIGHT
18 POUNDS

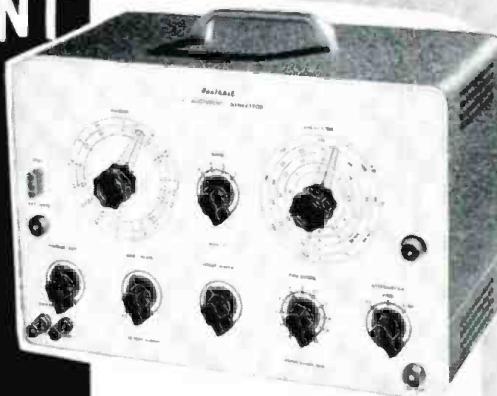

Proudly announcing an entirely new, advanced model TV and FM Sweep Generator, the Heathkit Model TS-3. This new design provides features and combinations of functions not found in any other service type instrument. Every design consideration has been given to the requirements of the TV service man to provide a flexible, variable sweep source with more than adequate RF output and complete frequency coverage throughout the TV and FM spectrum.

The frequency range of the TS-3 is from 4 mc to 220 mc in four switch selected ranges. All frequency ranges are overlapping for complete coverage. A particularly important feature of the instrument is that the oscillator operates entirely on fundamentals, thereby providing complete freedom from spurious oscillation and parasitics normally encountered in beat frequency type oscillators. This circuitry assures a much higher total RF output level and simplifies attenuation problems.

The new TS-3 features an entirely new principle of sweep operation. Sweep action is entirely electronic with no moving parts or electro-mechanical devices so commonly used. The heart of the sweep system is a newly-developed INCREDUCTOR controllable inductor. With this system, the value of inductance of each oscil-

lator coil is electrically varied with an AC control current, and the inductance variation is achieved by a change in the magnetic state of the core on which the oscillator coils are wound. This system provides a sweep deviation of not less than 12 mc on all TV frequencies, and up to a maximum of 30 mc on TV IF frequencies. The high RF output level throughout the instrument frequency range overcomes the most common complaint of the older type sweep generators. A new, automatic amplitude control circuit maintains the output level flat to ± 2 db throughout the instrument range. For convenience of operation a low impedance 50 ohm output is used.

Operation of the instrument has been simplified through the reduction of panel controls and separate panel terminals provide for external synchronization if desired. The circuit uses a voltage regulator tube to maintain stable instrument operation. A built-in variable oscillator marker further adds to flexibility of instrument operation. Provisions are also made for the use of an external marker, such as your service type signal generator, if desired. Use the Heathkit TS-3 for rapid, accurate TV alignment work, and let it help you solve those time consuming, irksome problems so frequently encountered.

NEW *Heathkit*
SIGNAL GENERATOR KIT

MODEL SG-8

\$19.50

SHIPPING WEIGHT
8 POUNDS



Announcing the new Heathkit Model SG-8 service type Signal Generator, incorporating many design features not usually found in an instrument in this price range. The RF

output is from 160 kc to 100 mc in five ranges, all on fundamentals, with useful harmonics up to 200 mc. The RF output level is in excess of 100,000 microvolts throughout the frequency range.

The oscillator circuit consists of a 12AT7 twin triode tube. One half is used as a Colpitts oscillator, and the other half as a cathode follower output which acts as a buffer between the oscillator and external load. This circuitry eliminates oscillator frequency shift usually caused by external circuit loading.

All coils are factory wound and adjusted, thereby completely eliminating the need for calibration and the use of additional calibrating equipment. The stable low impedance output features a step and variable attenuator for complete control of RF level. A 6C4 triode acts as a 400 cycle sine wave oscillator and a panel switching system permits a choice of either external or internal modulation.

The transformer operated circuit is easy to assemble, requires no calibration, and meets every service requirement for an adjustable level variable frequency signal source, either modulated or un-modulated.

NEW *Heathkit*
BAR GENERATOR KIT

MODEL BG-1

\$14.50

SHIPPING WEIGHT
6 POUNDS



The Heathkit BG-1 Bar Generator represents another welcome addition to the fast growing line of popular Heathkits. The

station transmitted test pattern is rapidly disappearing, and the bar generator is the logical answer to the TV service man's problem in obtaining quick, accurate adjustment information without waiting for test patterns.

The Heathkit BG-1 produces a series of horizontal or vertical bars on a TV screen. Since these bars are equally spaced, they will quickly indicate picture linearity of the receiver under test. Panel switch provides "stand-by position" — "horizontal position" — "vertical position." The oscillator unit utilizes a 12AT7 twin triode for the RF oscillator and video carrier frequencies. A neon relaxation oscillator provides low frequency for vertical linearity tests. The instrument will not only produce bar patterns but will also provide an indication of horizontal and vertical sync circuit stability, as well as overall picture size.

Instrument operation is extremely simple, and merely requires connection to the TV receiver antenna terminal. The unit is transformer operated for safety when used in conjunction with universal or transformerless type TV circuits.

HEATH COMPANY • Benton Harbor 15, Mich.

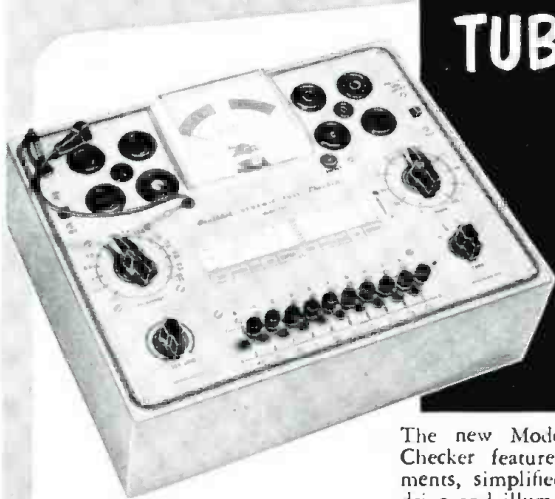

NEW *Heathkit* TUBE CHECKER KIT

MODEL TC-2

\$29⁵⁰

SHIP. WT. 12 LBS.

The new Model TC-2 Heathkit Tube Checker features many circuit improvements, simplified wiring, new roll chart drive and illumination of roll chart. The instrument is primarily designed for the convenience of the radio and TV service man and will check the operating quality of tubes commonly encountered in this type of work. Test set-up procedure is simplified, rapid, and flexible. Panel sockets accommodate 4, 5, 6, and 7 pin tubes, octal and loctal, 7 and 9 pin miniatures, 5 pin Hytron and a blank socket for new tubes. Built-in neon short indicator, individual three-position lever switch for each tube element, spring return test switch, 14 filament voltage ranges, and line set control to compensate for supply voltage variations, all represent important design features of the TC-2. Results of tube tests are read directly from a large 4½" Simpson three-color meter, calibrated in terms of Bad-?-Good. Information that your customer can readily understand. Checks emission, shorted elements, open elements, and continuity.

The use of closer tolerance resistors in critical circuits assures correct test information and eliminates the possibility of inaccurate test interpretation. Improvement has been made in the mechanical roll chart drive system, completely eliminating diagonal running, erratic operation, and backlash. The thumb wheel gear driven action is smooth, positive, and free running. As an additional feature, the roll chart is illuminated for easier reading, particularly when the tube checker is used on radio or TV home service calls.

Wiring procedure has been simplified through the extended use of multi-cable, color coded wires, providing a harness type installation between tube sockets and lever switches. This procedure insures standard assembly and imparts that "factory built" appearance to instrument construction. Completely detailed information is furnished in the new step-by-step construction manual, regarding the set-up procedure for testing of new or unlisted tube types. No delay necessary for release of factory data.

The new Heathkit Tube Checker will prove its value in building service prestige through usefulness—simplified operation—attractive professional appearance. Don't overlook the fact that the kit price represents a savings of \$40.00 to \$50.00 over the price of a comparable commercially built instrument. At this low price, no service man need be without the advantages offered by the Heathkit Tube Checker.

CHECK THESE NEW *Features*

- ✓ Simplified harness wiring
- ✓ Improved, smooth, anti-backlash roll chart action
- ✓ Optional roll chart illumination
- ✓ Individual element switches
- ✓ Portable or counter style cabinet
- ✓ Spare blank socket
- ✓ Contact type pilot light test socket
- ✓ Simplified test set-up procedure
- ✓ Line adjust control
- ✓ 4½" three-color meter

New

HEATHKIT PORTABLE TUBE CHECKER KIT

MODEL TC-2P

\$34⁵⁰

SHIP. WT. 14 LBS.

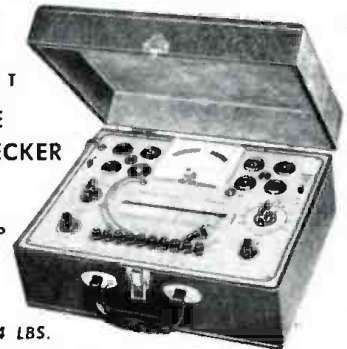

The portable model is supplied with a strikingly attractive two-tone cabinet finished in rich maroon, proxylin impregnated, fabric covering with a contrasting gray on the inside cover. Detachable cover, brass-plated hardware, sturdy plastic handle help to impart a truly professional appearance to the instrument.

PORTABLE TUBE CHECKER CABINET as described above will fit all earlier Heathkit TC-1 Tube Checkers. Shipping weight 7 lbs. Cabinet only. 91-8, \$7.50.



Heathkit TV PICTURE TUBE TEST ADAPTER

No. 355
Ship. Wt. **\$4⁵⁰**
1 lb.

The Heathkit TV Picture Tube Test Adapter used with the Heathkit Tube Checker will quickly check for emission, shorts, etc., and determine picture tube quality. Consists of standard 12 pin TV tube socket, four feet of cable, octal socket connector, and data sheet.

Heathkit POWER SUPPLY KIT

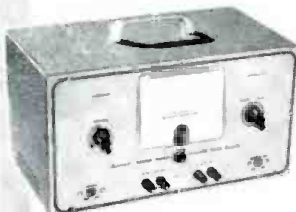

MODEL PS-2

\$33⁵⁰

SHIPPING WT.
17 LBS.

The Heathkit Laboratory Power Supply features continuously variable, regulated voltage output with good stability under wide load variations. A 4½" Simpson plastic enclosed panel mounted meter provides accurate meter output information of voltage or current. All panel terminals completely isolated from the cabinet. Separate 6.3 volt AC supply at 4 amperes for filament requirements. Ripple component exceptionally low, stand-by switch provided to eliminate warm-up time of the five tube circuit.



LABORATORY AND SERVICE SHOP BOOKLETS

"Planning Your Service Business" by John T. Frye, and "Establishing the Industrial Electronics Laboratory" by Louis B. Garner, Jr., are booklets available to Heathkit customers at no charge. These booklets, written by nationally recognized authorities, outline the various requirements and considerations for establishing your own service business or for setting up an industrial electronics laboratory. Full attention is given to various details that are frequently overlooked when projects of this nature are undertaken. Just write in to the Heath Company requesting your free copy, or attach a memo to your next order.

HEATH COMPANY • Benton Harbor 15, Mich.

CHECK THESE *Features*

- ✓ Visual and aural signal tracing
- ✓ Two channel input
- ✓ High RF sensitivity
- ✓ Unique noise locator circuit
- ✓ Calibrated wattmeter
- ✓ Substitution test speaker
- ✓ Utility amplifier
- ✓ RF, audio probes and test leads included

Heathkit VISUAL-AURAL SIGNAL TRACER KIT

MODEL T-3
\$23⁵⁰
SHIPPING WEIGHT
10 POUNDS



An entirely new type of signal tracer incorporating a combination of features not found in any other instrument. Designed expressly for the radio and TV service man, particularly for the servicing of AM, FM, and TV circuits. Here in a five tube, transformer operated instrument are all of the useful functions so necessary for speedy, accurate isolation of service difficulty.

This new signal tracer features a special high gain RF input channel, used in conjunction with a newly-designed wide frequency range demodulator probe. High RF sensitivity permits signal tracing at the receiver antenna input. A separate low gain channel and probe available for audio circuit exploration. Both input channels are constantly monitored by an electron ray beam indicator, so that visual as well as aural signal indications may be observed. The instrument can also be used for comparative estimation of gain per stage.

A decidedly unusual feature is a noise localizer circuit in conjunction with the audio probe. With this system, a DC potential is applied to a suspected circuit component and the action of the

voltage in the component can be seen as well as heard. Invaluable for ferreting out noisy or intermittent condensers, noisy resistors, controls, coils, IF and power transformers, etc. A built-in calibrated wattmeter circuit is very useful for a quick preliminary check of the total wattage consumption of the equipment under test. Separate panel terminals provide external use of the speaker or output transformer for substitution purposes. Saves valuable service time by eliminating the necessity for speaker removal on every service job. The terminals also permit the utilization of other shop equipment, such as your oscilloscope or VTVM. The T-3 Signal Tracer can be used as a high gain amplifier for checking tuners, record changers, microphones, phono crystals, etc.

Don't overlook the interesting service possibilities provided through the use of this new instrument and let it work for you by saving time and money. The kit is supplied complete with all tubes, circuit components, demodulator probe, audio probe, and additional test leads.



Heathkit DECADE RESISTANCE KIT

MODEL DR-1 The Decade Resistance Kit provides individual switch selection of resistance values using twenty 1% resistors providing a choice of 1 to 99,999 ohms in 1 ohm steps. Ceramic wafer switches, silver-plated contacts, smooth, positive detent action, baked enamel panel, and handsome, polished birch cabinet.

\$19⁵⁰
SHIP. WT.
4 LBS.

Heathkit DECADE CONDENSER KIT

The Heathkit Decade Condenser Kit features silver mica, precision condensers with a rated accuracy of $\pm 1\%$. Capacity values are arranged in three decades from 100 mmf to .111 mf in steps of 100 mmf. Ceramic wafer switches with silver-plated contacts and smooth detent action. Useful in laboratory work, for circuit development.



MODEL DC-1
\$16⁵⁰
SHIP WT.
4 LBS.

Heathkit RESISTANCE SUBSTITUTION BOX KIT



MODEL RS-1 The Heathkit Resistance Substitution Box provides individual switch selection of any one of 36 RTMA 1 watt 10% standard value resistors, ranging from 15 ohms to 10 megohms. Many applications in circuit development work, and also in radio and TV service work. Ideal for experimentally determining resistance values and for quickly altering circuit operating characteristics. Entire unit housed in attractive Bakelite cabinet, featuring the new universal type Heathkit binding posts to simplify circuit connections.

\$5⁵⁰
SHIP. WT.
2 LBS.

Heathkit CONDENSER CHECKER KIT



MODEL C-3
\$19⁵⁰
SHIPPING WT.
8 POUNDS

Use the Heathkit C-3 Condenser Checker to quickly and accurately measure those unknown condenser and resistor values. All readings are taken directly from the calibrated panel scales without requiring any involved calculation. Capacity measurements in four ranges from .00001 mf to 1,000 mf. Checks paper, mica, ceramic, and electrolytic condensers. A power factor control is available for accurate indication of electrolytic condenser measurements. A leakage test switch with switch selection of five polarizing voltages, 25 volts to 450 volts DC, will indicate condenser operating quality under actual load condition. The spring return leakage test switch automatically discharges the condenser under test and eliminates shock hazard to the operator.

Resistance measurements can be made in the range from 100 ohms to 5 megohms. Here again all values are read directly on the calibrated scale. Increased circuit sensitivity coupled with an electron beam null indicator increases overall instrument usefulness.

For safety of operation the circuit is entirely transformer operated and the instrument is housed in the attractive, newly-styled Heathkit cabinet, featuring rounded corners, and drawn aluminum panel. The outstanding low kit price for this surprisingly accurate instrument includes necessary test leads. Good service shop operation requires the use of this specialized instrument, designed for the express purpose of determining unknown condenser values and operating characteristics.

HEATH COMPANY • Benton Harbor 15, Mich.



Heathkit AMATEUR TRANSMITTER KIT

MODEL AT-1

\$29.50

SHIPPING WEIGHT
16 POUNDS

CHECK THESE NEW Features

- ✓ Single knob band switching
- ✓ Pre-wound coils
- ✓ Metered operation
- ✓ 52 ohm coaxial output
- ✓ Crystal or VFO excitation
- ✓ Built-in power supply
- ✓ Rugged, clean construction

Here is the latest Heathkit addition to the ham radio field, the AT-1 Transmitter Kit, incorporating many desirable design features at the lowest possible dollar-per-watts price. Panel mounted crystal socket, stand-by switch, key click filter, AC line filtering, good shielding, etc. VFO or crystal excitation — up to 35 watts input. Built-in power supply provides 425 volts at 100 ma.

This kit features pre-wound coils, single knob band switching, 52 ohm coaxial output, plug in chassis provisions for VFO or modulator and rugged clean construction. Frequency range 80, 40, 20,

15, 11, and 10 meters. Tube line-up 6AG7 oscillator-multiplier, 6L6 amplifier-doubler, 5U4G rectifier. Physical dimensions 8 1/8" high x 13 1/8" wide x 7" deep.

This amazingly low kit price includes all circuit components, tubes, cabinet, punched chassis, and detailed construction manual. The ideal kit for the novice just breaking into ham radio. It can be used later on as a stand-by rig or an all band exciter for higher powered transmitter.

NEW Heathkit ANTENNA COUPLER KIT

New Heathkit Antenna Coupler, specially designed for the Heathkit AT-1 Transmitter. The Antenna Coupler can be used with any 52 ohm coaxial input — up to 75 watts power. Low pass filter with cut-off frequency of approximately 36 mc — L section tuning network — neon tuning indicator — rugged, compact construction — transmitter type variable condenser, and high Q coil are all outstanding features. The AC-1 has both inductance and capacity tuning for maximum operating versatility. Dimensions 8 1/8" wide x 4 1/8" high x 4 7/8" deep.

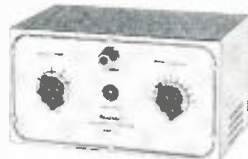

MODEL AC-1

\$14.50 SHIP. WT.
3 LBS.

Heathkit ANTENNA IMPEDANCE METER

Use the Heathkit Antenna Impedance Meter for measuring antenna impedance for line matching purposes — adjustment of beam antennas — phone monitor, etc. It will determine antenna resistance at resonance, match transmission line for minimum SWR, determine receiver input impedance, and provide a rough indication of SWR. Precision resistors, germanium diode, 100 micro-ampere Simpson meter. Dial calibrated from 0-500 ohms. Shielded aluminum cabinet, 7" long x 2 1/2" wide x 3 1/4" deep.

\$14.50

SHIP. WT. 3 LBS.



MODEL AM-1

Heathkit COMMUNICATIONS RECEIVER KIT

MODEL AR-2

\$25.50 SHIP. WT.
12 LBS.



Here is the new receiver kit you have repeatedly asked for, the Heathkit Communications Receiver. The perfect companion piece for the AT-1 Transmitter kit. Many outstandingly desirable features have been incorporated in the design of the AR-2; such as, electrical bandwidth for logging and tuning convenience — high gain miniature tubes — IF transformers for high sensitivity and good signal to noise ratio — separate RF gain control with optional automatic volume control or manual volume control, in addition to the conventional audio gain control. Noise limiter — stand-by switch — stable BFO oscillator circuit — headphone jack — transformer operation, etc., all contribute to a high performance standard.

Frequency coverage is continuous from 535 kc to 35 mc in four ranges. For added convenience, various ham bands have been separately identified in respect to their relative placement on the slide rule tuning scale. A chassis mounted, 5 1/2" PM speaker is included with this kit. Tube line up 12BE6 mixer oscillator, 12BA6 IF amplifier, 12AV6 detector AVC audio, 12BA6 BFO oscillator, 12A6 beam power output, 5Y3GT rectifier.

RECEIVER CABINET

Proxilyn impregnated, fabric covered, plywood cabinet with aluminum panel designed expressly for the AR-2 Receiver, Part 91-10, shipping weight 5 lbs., \$4.50.



IMPROVED Heathkit GRID DIP METER KIT

\$19.50 SHIP. WT.
4 LBS.

MODEL GD-1B

The invaluable instrument for service men, hams, and experimenters. Useful in TV service work for alignment of traps, filters, IF stages, peaking compensation networks, etc. Locates spurious oscillation, provides a relative indication of power in transmitter stages, use it for neutralization, locating parasitics, correcting TVI, measuring C, L, and Q of components, and determining RF circuit resonant frequencies. With oscillator energized, useful for finding resonant frequency of tuned circuits. With the oscillator not energized, the instrument acts as an absorption wave meter. Variable meter sensitivity control, head phone jack, 500 microampere Simpson meter. Continuous frequency coverage from 2 mc. to 250 mc. Pre-wound coil kit and rack, new three prong coil mounting, 6AF4 high frequency triode.

Two additional plug-in coils are available and provide continuous extension of low frequency coverage down to 355 kc. Dial correlation curves included. Shipping weight 1 lb., kit 3-41, \$3.00.



HEATH COMPANY • Benton Harbor 15, Mich.

CHECK THESE *Features*

- ✓ First popular priced Q Meter
- ✓ Reads Q directly on calibrated scale
- ✓ Oscillator supplies RF frequencies of 150 kc to 18 mc
- ✓ Calibrate capacitor with range of 40 mmf to 450 mmf with vernier of ± 3 mmf
- ✓ Measures Q of condensers, RF resistance, and distributed capacity of coils
- ✓ Many applications in design and development work
- ✓ Useful in TV service work for checking deflection yokes, coils, chokes, etc.

Heathkit "Q" METER KIT

MODEL QM-1

\$44.50

SHIPPING WT. 14 POUNDS

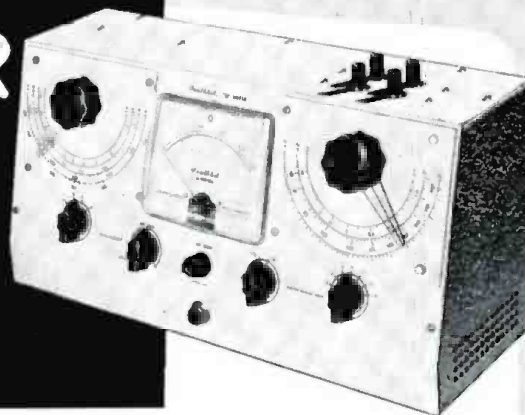

Another outstanding example of successful Heathkit engineering effort in producing a Q Meter Kit within the price range of TV service men, schools, laboratories, and experimenters. This Q Meter meets RF design requirements for rapid, accurate measurement of capacity, inductance, and Q at the operating frequency and all indications of value can be read directly on the meter calibrated scales. Oscillator section supplies RF fre-

quencies of 150 kc to 18 mc. Calibrate capacitor with range of 40 mmf to 450 mmf, with vernier of ± 3 mmf.

Particularly useful in TV service work for checking peaking coils, wave traps, chokes, deflection coils, width and linearity coils, etc. At this low kit price research laboratory facilities are within the range of service shops, schools, and experimenters.

Heathkit INTERMODULATION ANALYZER KIT



MODEL IM-1

\$39.50

SHIPPING WT.
17 POUNDS

The Heathkit IM-1 is an extremely versatile instrument specifically designed for measuring the degree of inter-action between two signals in any portion of an audio chain. It is primarily intended for making tests of audio amplifiers, but may be used in other applications, such as checking microphones, records, recording equipment, phonograph pick-ups, and loud-speakers. High and low test frequency source, intermodulation unit, power supply, and AC vacuum tube volt meter all in one complete instrument. Per cent intermodulation is directly read on the calibrated scales, 30%, 10%, and 5% full scale. Both 4:1 and 1:1 ratios of low to high frequency easily set up. With this instrument the performance level of present equipment, or newly developed equipment can be easily and accurately checked. At this low price, you can now enjoy the benefits of intermodulation analysis for accurate audio interpretation.

Heathkit AUDIO GENERATOR KIT

A Heathkit Audio Generator with frequency coverage from 20 cycles to 1 mc. Response flat ± 1 db from 20 cycles to 400 kc, down 5 db at 600 kc, and down only 8 db at 1 mc. Calibrated, continuously variable, and step attenuator output controls provide convenient reference output level. Distortion is less than .4% from 100 cps through the audible range. The ideal controllable extended frequency sine wave source for audio circuit investigation and development.



MODEL AG-8

\$29.50

SHIP. WT. 11 LBS.

Heathkit AUDIO OSCILLATOR KIT

Sine or square wave coverage from 20 to 20,000 cycles in three ranges at a controllable output level up to 10 volts. Low distortion, 1% precision resistors in multiplier circuits, high level output across entire frequency range, etc., readily qualify this instrument for audio experimentation and development work. Special circuit design consideration features thermistor operation for good control of linearity.

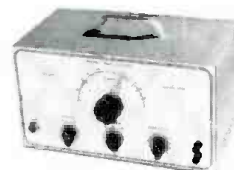

MODEL AO-1

\$24.50

SHIP. WT. 11 LBS.

Heathkit AUDIO FREQUENCY METER KIT



MODEL AF-1

\$34.50

SHIP. WT. 12 LBS.

The Heathkit Audio Frequency Meter provides a simple and convenient means of checking unknown audio frequencies from 10 cycles to 100 kc at any voltage level between 3 and 300 volts rms with any non-critical wave shape. Instrument operation is entirely electronic. Just set the range switch, feed an unknown frequency into the instrument, and read the frequency directly on the calibrated scale of the Simpson 4 1/2" meter.

Heathkit SQUARE WAVE GENERATOR KIT



MODEL SQ-1

\$29.50

SHIP. WT. 12 LBS.

The Heathkit Square Wave Generator provides an excellent square wave frequency source with completely variable coverage from 10 cycles to 100 kc. This generator features low output impedance of 600 ohms and the output voltage is continuously variable between 0 and 20 volts, thereby providing the necessary degree of operating flexibility. An invaluable instrument for those specialized circuit investigations requiring a good, stable, variable square wave source.

HEATH COMPANY • Benton Harbor 15, Mich.

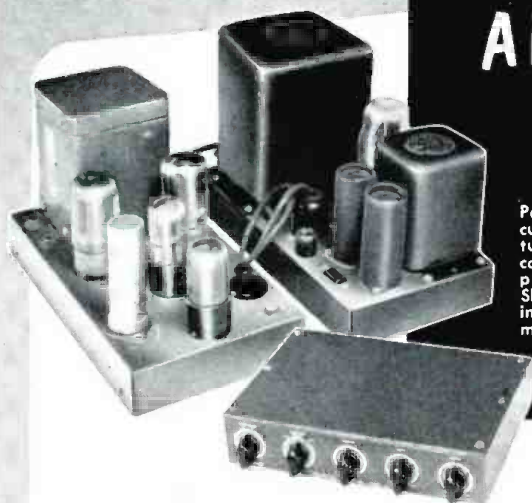

Heathkit WILLIAMSON TYPE AMPLIFIER KIT

MODEL W-2

Particularly designed for custom installations, featuring separate cable connected units for simplicity of installation. Sheet metal work finished in attractive gray hammer-tone for smart appearance. All control shafts of the adjustable length break-off type.

\$69.50

PRICES OF COMBINATIONS

W-2 Amplifier Kit including main amplifier, power supply, and WA-P1 Preamplifier Kit. Shipping Weight 37 lbs. Shipped Express only. **\$69.50**

W-2M Amplifier Kit includes main amplifier and power supply. Shipping Weight 29 lbs. Shipped Express only. **\$49.75**

WA-P1 Preamplifier Kit only. Shipping Weight 6 lbs. Shipped Express or Parcel Post. **\$19.75**

When selecting an amplifier for the heart of your high fidelity audio system, investigate the outstanding advantages offered by the Heathkit Williamson Type Amplifier. Meets every high fidelity audio requirement and makes listening to recorded music a thrilling new experience. This outstanding amplifier is offered with optional output transformer

operation, providing either the conventional triode output circuit or the new extended power circuitry in which the screen supply voltage is obtained from separate transformer primary taps. Frequency response within ± 1 db from 10 cycles to 100 kc. Tube complement — 6SN7 cascade amplifier and phase splitter, 6SN7 push pull driver, two 5881 push pull power amplifiers, one 5V4G cathode type rectifier.

Matching preamplifier available providing three switch selected inputs, correct compensation, and individual bass and treble tone controls. Uses 12AY7 (or 12AX7) preamplifier — 12AU7 tone control amplifier.

Particularly designed for the novice kit builder and requires no specialized knowledge or equipment for successful assembly and operation.

NEW Heathkit 20 WATT High Fidelity AMPLIFIER KIT

MODEL A-9A

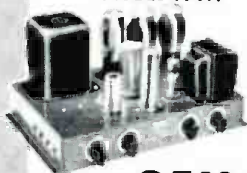

\$35.50

SHIP. WT. 18 LBS.

A new 20 watt high fidelity amplifier, designed especially for custom audio installations demanding clean reproduction, adequate power, and flexibility to meet individual requirements. Separate treble and bass tone controls provide up to 15 db boost or cut. Four switch selected inputs, each with the necessary compensation for the service desired. Output transformer impedances of 4, 8, and 16 ohms. Preamplifier, tone control, and phase splitter circuits utilize 9 pin twin triode miniature tubes for low hum and noise level. Two 6L6 push pull power output tubes provide full 20 watts power. Frequency response ± 1 db, 20-20,000 cycles. Total harmonic distortion 1% (at 3 db below rated output). Tube line-up: 12AX7 preamplifier, 12AU7 voltage amplifier and tone control, 12AU7 voltage amplifier and phase splitter, two 6L6 push pull pentode power output, 5U4G rectifier. Truly outstanding amplifier performance coupled with low cost.

Heathkit ECONOMY 6 WATT AMPLIFIER KIT

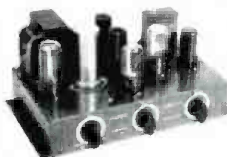

MODEL A-7B

\$15.50

SHIP. WT. 10 LBS.

The new Heathkit Model A-7B Amplifier offers many unusually fine features not normally expected in this low price range. Either of the two input circuits may be individually switch selected for phono or tuner operation. Separate bass and treble tone controls. Output impedances of 4, 8, and 15 ohms. Push pull beam power output stage for balanced reproduction. Excellent voltage gain characteristics, good frequency response, and full 6 watts power output. 12J5 amplifier, 12SL7 second amplifier and phase splitter, two 12A6 beam power output, one 5Y5 GT rectifier.

A-7C incorporates preamplifier stage with special compensated network to provide necessary gain for operation with variable reluctance or low output level phono cartridge. Circuit is properly compensated for microphone operation. \$17.50.

NEW Heathkit BROADCAST BAND RECEIVER KIT

Another new Heathkit for the student, beginner, or hobbyist. If you have ever had the urge to build your own radio receiver, this kit warrants your attention.

New high gain miniature tubes and IF transformers provide excellent sensitivity and good signal to noise ratio. A built-in ferrite core rod type antenna has been provided. A chassis mounted 5 1/2" PM speaker provides excellent tone and volume. Convenient phono input. Can be operated either as a receiver or tuner. Simplified construction manual outlines circuit theory. Ideal for students. Tube line-up: 12BE6 mixer oscillator, 12BA6 IF amplifier, 12AV6 detector-AVC-first audio, 12A6 beam power output, 5Y3GT rectifier.

CABINET — Proxylin impregnated fabric covered plywood cabinet. Shipping weight 5 lbs. Parr number 91-9, \$4.50.



MODEL BR-2

\$17.50 SHIP. WT. 11 LBS.

Heathkit FM TUNER KIT



MODEL FM-2

\$22.50

SHIP. WT. 9 LBS.

The Heathkit FM-2 Tuner was specifically designed for simplified kit construction. Can be operated through the "phono" portion of your radio or with a separate amplifier. The kit features a pre-assembled and adjusted tuning unit, three double tuned IF transformers, and a discriminator transformer in an 8 tube AC operated circuit. Frequency coverage 88 to 108 mc. Experience the thrill of building your own FM tuner and at the same time enjoy all of the advantages of true FM reception.

Free CATALOG

Write for free catalog containing latest price information, schematics, specifications, and descriptions of all Heathkits.

HEATH COMPANY • Benton Harbor 15, Mich.

AIREX'S 1954 Co-Channel

630 FA-2A with Genuine FM
Armstrong Sound System

3 MONTHS
RMA
GUAR.
ON ALL
PARTS

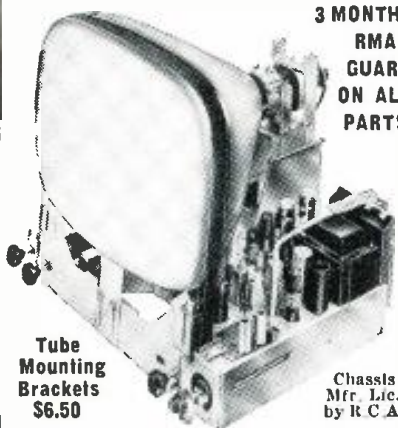

Tube
Mounting
Brackets
\$6.50

Chassis
Mfr. Lic.
by R C A.

Here is the most powerful fringe area chassis on the market today . . . the one TV engineers and servicemen are buying for themselves. Clear, sharp, exceptional reception up to 200 miles.

CHECK THESE EXCLUSIVE FEATURES

- 10 WATT push-pull audio output. Frequency range from 40 to 12,000 cycles • 3 position fringe area switch • Delayed gated AGC system • Standard Coil Cascade Tuner prevents radiation • Retrace Blanking Circuit allows you to raise the brightness without the annoying vertical retrace lines • Heavy duty front focus control • Automatic gain control potentiometer allows you to adjust the threshold sensitivity as low as 4 microvolts & still keep the full 4 MC band width • Improved sync amplifier • Improved automatic brightness control • Set aligned for 21.9 MC. New Ham band will not interfere • Improved fused high voltage power supply gives full 14.5 KV under load. Will handle all picture tubes up to 24 inch with full sweep • Improved video amplifier has a gain of 40 • All moulded plastic condensers give long life & trouble-free operation • Easily adapted to new UHF stations in 2 minutes by just changing a strip in the tuner • Extra heavy duty power transformer with large safety factor • 6CB6 tubes in Video IF to give full gain • Extra filtering in power supply for hum & ripple-free operation • Phono Connection & switch on chassis allows you to play your phonograph or tuner through the built-in 10 watt hi-fidelity amplifier • Extra heavy duty focus coil, which runs cool • Full focus cosine yoke.

THE ONLY CHASSIS WITH 10 WATT
PUSH-PULL AUDIO OUTPUT AT

\$169⁹⁵

Fed. Tax
Included

Less C.R. Tube
and Brackets

Complete with 12" ROLA Hi-Fi Speaker
With UHF 83 Channel Converter—\$211.90
Detailed Service Manual & Schematic—\$1

TV PICTURE TUBE SALE

Standard Brands. Factory
New. Guar. 1 year.

- 17" Tube . . . \$27.95
- 20" Tube . . . \$34.95
- 21" Tube . . . \$39.95
- 24" Tube
(Guar. 6 Mos.) \$79.95
- 27" Tube . . . \$79.95
- Ring and Sleeve
for 24" . . . \$ 7.50

630 CHASSIS
FOR 24" & 27" RECT.
OPERATION
PRICE . . . \$189⁹⁵

Not push pull audio

TV GOLD PLASTIC MASKS

16" and 17" . . . \$ 4.95
20" and 21" . . . \$ 7.95
24" . . . \$14.95

UHF SLUGS—\$7.95

BARGAIN CABINET BUY

Beautiful mahogany console cabinet cut
for 630 FA-2A Chassis. Complete with
mask, glass & tube mounting brackets. . . \$49.95
In Stock . . . \$59.95

Send for complete cabinet brochure

FREE—New TV—Hi-Fi PARTS CATALOG

All merchandise brand new, factory fresh, guaranteed.
Mail & phone orders filled upon receipt of certified
check or money order for \$25 as deposit on TV chassis.
20% on other items. Balance C.O.D., F.O.B.
N. Y. Prices & specifications subject to change with-
out notice. NO FED. TAXES TO PAY.

AIREX RADIO CORP.

SHOWROOM: 171 Washington St., N. Y. 7
Gramercy 7-9245
MAIL ORDER: 400 Lafayette St., N. Y. 3

MEASURING RESISTANCE BETWEEN TUBE ELEMENTS

By

LLOYD J. AUSTIN

Simpson Electric Co.

Meter indication of tube shorts provides complete data for the technician.

ONE standard test, which is made with all tube testers, measures the amount of resistance between the elements of the tube being tested. This "short test" is usually accomplished by a circuit similar to that shown in Fig. 1A. The neon lamp remains dark when the tube is good and glows when there is a short between two of the tube elements.

Although this system has some limitations it has come to be accepted by both service technicians and customers as a valid indication of tube condition. Simpson Electric Company has developed a variation of this short test circuit which has been incorporated in its new Model 1000 tube tester.

The new circuit, shown in Fig. 1B, is designed to give more complete information about the inter-element condition within the tube being tested. It sets up a meter circuit to read the inter-element leakage resistance directly on an ohmmeter scale. In order to take advantage of the psychological effect of the neon lamp, the scale markings are black for values above 250,000 ohms and red for lower values. The operator can still judge his short indications by the familiar methods—an indication in the red area being the same as a glowing lamp. In addition, the metered indication will tell the operator just how good or how bad the resistance condition is by direct reading. He can then judge the results of applying the tube in a particular circuit.

Other circuitry within the tester makes it possible to determine which of the tube elements is involved in any particular leakage resistance indication. Each short test separates one element from all others in the tube

The Simpson
Model 1000 tube
tester which in-
corporates spe-
cial short test.

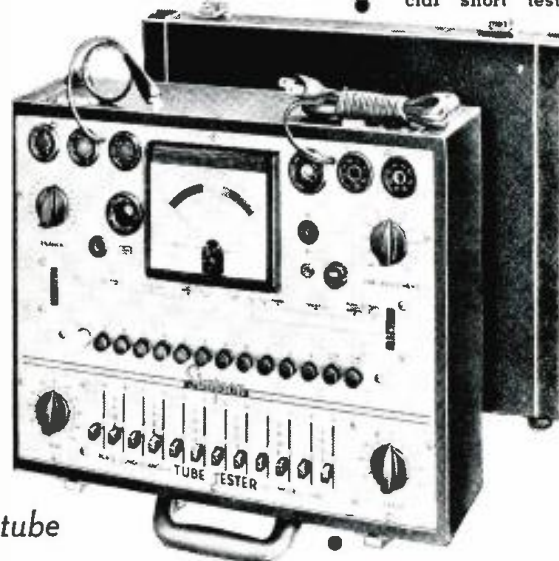

and indicates whether that element is involved in a short circuit. The short test buttons are identified by letter. Button A separates the tube element connected to tube socket pin #1; button B controls the #2 pin circuit; button C controls the #3 circuit, and so on through all possible base pins and the clip on the cap of the tube.

During the short tests the tube filament is heated with its normal filament voltage. All the other elements are connected to ground, then one element at a time is separated from ground. The voltage supply and meter are connected in series with the element circuit in parallel with part of the meter circuit. If there is any path through which current can be made to flow between elements within the tube, the current flow through the meter is increased. This makes the meter pointer deflect further across the scale and the amount of deflection

Fig. 1. (A) Standard short test circuit using a neon bulb as an indicator. (B) New short checker in the Model 1000.

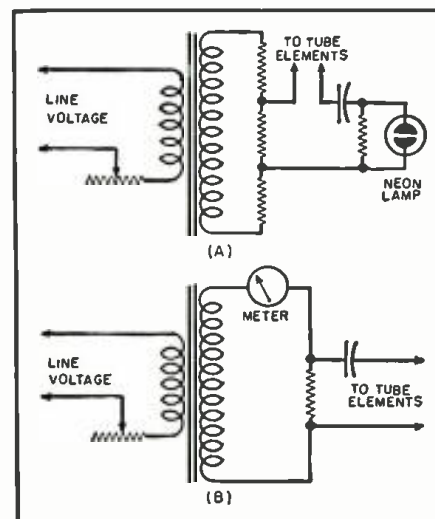

BACK THE LINE THAT BACKS YOU!

ALLIANCE

New, Restyled Models + \$500,000 Ad Campaign



IMPROVED ROTATOR UNIT
 —Speed increased to 2 rpm.
 Magnetic anti-drift brake.
 Smoother synchronization
 with control units.

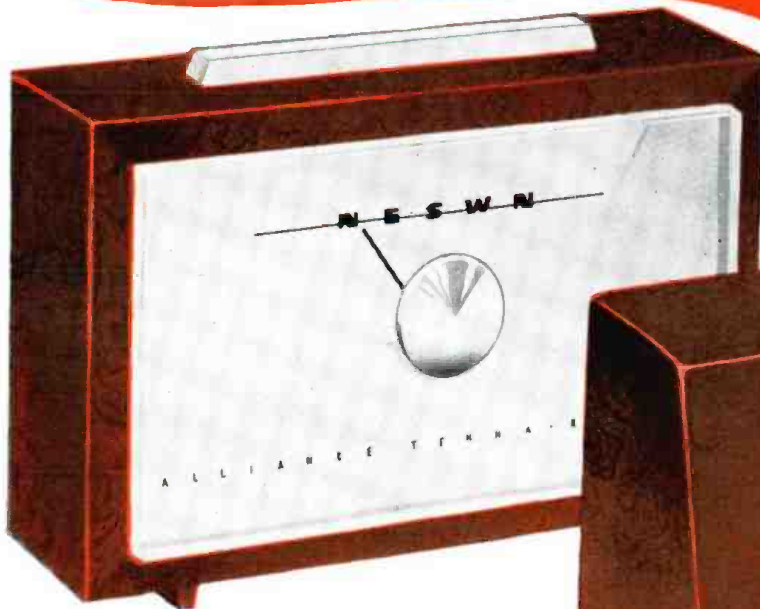

MODEL T-10, finger-tip electrically controlled Alliance Tenna-Rotor with direction indicator dial. Extremely accurate. Modern styling by Reinecke & Associates \$44.95

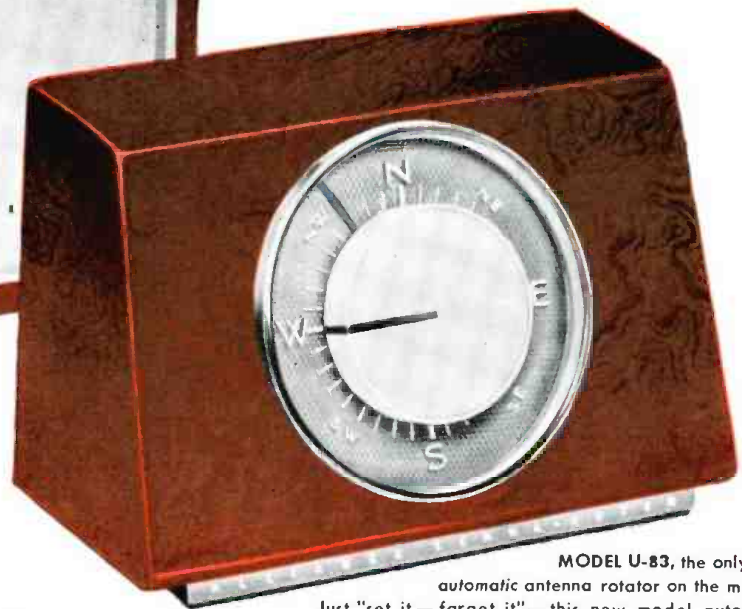

MODEL U-83, the only fully automatic antenna rotator on the market. Just "set it—forget it"—this new model automatic Alliance Tenna-Rotor. Reinecke-designed . . . \$44.95

Here's how Alliance pre-sells for you!—

1 New styling sells on sight! Style's the thing, and Alliance has it! More eye-appeal, more buy-appeal in these smart, new Alliance Tenna-Rotors and the Alliance TV Converter! Boost your sales, boost your profits with Alliance—the line that backs you!

2 \$500,000 ad campaign sends sales your way! Alliance keeps spring promises!

TV Spots—eye-compelling "home" demonstrations—more than 16 million viewers on more than 100 stations—*this is our fifth straight year of TV advertising!*



ALLIANCE TV CONVERTER

adds all new UHF channels. Advertised on TV! The quality converter built to last! \$42.50



— full-page ad in this top consumer magazine! Newspapers—dominant, sales-making ads in key markets! Point-Of-Sale Displays—full-color, on-the-spot reminders!

OVER ONE AND ONE-QUARTER MILLION ALLIANCE TENNA-ROTORS NOW IN USE!

ALLIANCE MANUFACTURING CO., ALLIANCE, OHIO

SAVE ON INSTRUMENTS!

- do better testing with fewer instruments
- avoid buying costly equipment you don't really need
- discover new uses for old instruments
- learn all about ALL instrument types; how to use them more efficiently; how to interpret their readings



BASIC ELECTRONIC TEST INSTRUMENTS

by Rufus D. Turner

254 pages, 171 illus. Price only \$4

Get the real "low-down" on

- Current and voltage meters
- TV pattern generators
- Grid-dip oscillators
- Oscilloscopes
- Ohmmeters
- Volt-Ohm-Milliammeters
- V-T voltmeters
- Power meters
- Capacitor checkers
- Impedance meters
- Special bridges
- Tube testers
- TV sweep and marker generators
- Distortion meters
- TV linearity pattern generators
- Square-wave generators
- Signal tracers
- Signal generators
- R-F test oscillators
- Inductance checkers
- R-F and A-F measuring devices

... and over 30 other standard instrument types!

This book can save you hundreds of dollars by avoiding unnecessary instrument purchases! And it can help you handle all kinds of testing faster and more accurately in the bargain by putting your present instruments to better use!

Actually, BASIC ELECTRONIC TEST INSTRUMENTS is a complete training course covering over 60 instrument types for TV and radio service, ham and experimental use. The author's whole object is to help you do better work; choose instruments intelligently and use them fully. Dozens of work-saving short-cuts are outlined. New uses for old instruments are clearly explained.

Practically all present day instruments—including the latest television types—are impartially discussed. You learn exactly how to use each type and to know exactly what it can and cannot do.

Learn These Money-Saving Instrument "Tricks"

You discover new uses for VOM's, oscilloscopes, signal generators, etc. You see how to extend the range of many old instruments; how to use power drain measurements for fast TV troubleshooting; how a bridge can be built from old instruments; how to measure r-f impedance the easy way; how to measure inductance and capacitance with a grid-dip oscillator and dozens of other money-saving "tricks."

Use coupon!

10 DAY FREE TRIAL

Dept. RN-14, Rinehart Books, Inc., Technical Div., 232 Madison Ave., New York 16, N. Y.

Send Turner's BASIC ELECTRONIC TEST INSTRUMENTS for 10-day FREE examination. If I decide to keep book, I will then remit \$4.00 plus postage. Otherwise, I will return book postpaid promptly and owe you nothing.

Name

Address

CITY Zone State

OUTSIDE U.S.A.—Price \$1.50 cash only. Money back if book is returned in 10 days.

indicates the leakage resistance between the elements.

Application

As an example of application, consider a circuit in which a 6SN7 tube is being used as a multivibrator. The output of the circuit is supposed to be a balanced square wave and the frequency has been obtained with 680,000 ohms of resistance between each control grid and cathode.

The circuit was not functioning properly and an oscilloscope indicated that the waveform was out of balance and the frequency had shifted. An ohmmeter check of the circuit indicated that the resistances were normal. The tube was placed in the Model 1000 circuit for checking. The short test indicated that the inter-element resistance between pins 1 and 3 was infinite but the resistance between pins 4 and 6 was 400,000 ohms.

Because of this condition within the tube, one of the cathode-to-grid circuits had 680,000 ohms resistance while the other had only about 375,000 ohms. This was an unmistakable clue as to the cause of trouble in the multivibrator circuit. An ohmmeter check with the tube in the socket might show the short but not if the inter-element leakage resistance was present only when the tube was heated.

For another example of the usefulness of this circuit consider a power amplifier stage using a 6L6 tube where the grid resistor is 10,000 ohms and the cathode resistor is 680 ohms. When the 6L6 was checked in the tester, the inter-element leakage resistance from pin 8 (cathode) to pin 5 (grid) indicated about 175,000 ohms resistance between these elements. A comparison between the leakage read on the tester and the amount of circuit resistance between these two elements showed that the tube could still be used in this particular circuit without reflecting any change in operation due to leakage resistance.

Tape Editor's Notebook

(Continued from page 41)

for getting an in-phase splice. But there will be times when it will be impossible to edit out noise with a result that is completely unnoticeable.

The serious job of noise editing, then, requires at least as much judgment as it does dexterity. The editor must learn to judge which noises can be removed without difficulty, and which are almost certain to cause trouble. Then he must decide which will be the most annoying: the noise as is, or the skip introduced by its removal. And for this he needs a lot of practice, and even more patience.

Next month we shall conclude with a discussion of a number of tricks for which tape is useful. While not usually encountered in everyday operation, they should prove handy to know.

(To be concluded)

SCR-274N COMMAND and ARC-5 EQUIPMENT

RECEIVERS	USE D	EXCELLENT USED	NEW
BC-453—190 to 550 KC	529.95		\$49.95
BC-454—3 to 6 MC			24.95
BC-455—6 to 9 MC	5.95 (as is)	\$13.95	19.95
1.5 to 3			34.95

TRANSMITTERS			
A 958—2.1 to 3 MC			29.95
BC-457—4 to 5.3 MC		14.95	
BC-458—5.3 to 7 MC	9.95	14.95	29.95
BC-459—7 to 9.1 MC			24.95
T-15 ARC 5—500 to 800 KC			29.95

ADDITIONAL EQUIPMENT			
BC-456 Modulator	1.49	1.95	7.29
BC-450 Control Box (3 Receiver)			
BC-451 Control Box (Transmitter)	1.29	1.79	
BC-442 Relay Unit (ANT)			5.69
Plus: PL-147, 148, 151, 152, 153,			
154, 156—EACH		1.25	
Flexible Shifting with gear to fit receivers			2.69
3 Receiver Rack	1.79	2.29	2.98
2 Transmitter Rack	1.69	2.39	3.97
Single Transmitter Rack			3.97
DM-33 Dynamotor for Command Set		2.95	3.95
Mounts for Above Racks		1.95	

TUBES	BRAND NEW! JAN!	NEW! BOXED!	TUBES
1H22 69c	114B 29c	841 29c	
1H23 \$3.75	215A 09c	843 17c	
2C26 49c	221A 29c	R44 19c	
2C26 09c	310A 29c	1A36 19c	
2C34A 99c	3RRA 59c	71B3 19c	
1H23 \$1.19	471A 29c	694 69c	
1H16 39c	512A \$1.19	E1148 49c	
7C1 39c	722A 99c	HK71 99c	
19K8V 39c	801A 39c	14C 14c	
15R 39c	836 39c	VT127 15c	
3B744 29c			

T9/APQ-2 RADAR TRANSMITTER
80/115 V 100-260-26 VDC.
Designed primarily for aircraft operation.
NEW! \$19.95

AS-65/APQ-2 ANTENNA ASSY. FOR APQ-2. COMPLETE—BRAND NEW.....\$6.95

HEADSETS

- HS-29 high impedance, BRAND NEW with ear pads.....\$4.65
- HS-31 low impedance, BRAND NEW with ear pads, cord and PL-34 PLUG..... 5.65
- CS-307A Cord, 6 ft., NEW.....\$1.49
- HS-16 U high impedance. Includes two receiving units..... 3.95
- HS-16 high impedance—used..... .98

R-47/ARN-5 Glide-Path Receiver
R-47 is a single-channel Glide-Path Receiver tunable from 330 to 310 mc. Excellent condition, less tubes. Operates on 24 VDC..... **\$9.95**

RADIO CONTROL BOX BC-732-A
used with R-47/ARN-5 also R-57 and R-89/ARN-5..... **\$1.95**

LP-21-A LOOP
Used with BC-433 & R5-ARN-7 Army Compass Receivers. Excellent. Used..... **\$19.95**

BC-221 Frequency Meter
Real Value! QUANTITY IS LIMITED—so first come, first served. They are just like new, with original calibration charts. Range 125-20,000 KC with crystal check points in all ranges. Complete with crystal and tubes..... **\$139.50**
MODIFIED TYPE with AC power supply..... \$169.50
These Frequency Meters are factory treated, checked for frequency alignment and GUARANTEED.

SPECIAL!
20 LBS. of ASSORTED RADIO PARTS
A terrific buy at only **\$1.99**

MINIMUM ORDER \$2.00
Immediate Delivery—Send 25% deposit on C.O.D. orders. All shipments F.O.B., N.Y.C. (N.Y.C. residents add sales tax to your remittance.)

PLATT ELECTRONICS CORP.
Dept. A, 489 Broome St., N. Y. 13, N. Y.
PHONES: WO 4-0827 and WO 4-0828
BRANCH STORE: 159 Greenwich St., N.Y.C.

Technical BOOKS

"HOW TO USE SIGNAL & SWEEP GENERATORS" by J. Richard Johnson. Published by *John F. Rider Publisher, Inc.*, New York. 133 pages. Price \$2.00. Paper bound.

This is a practical handbook for the service technician, the radio amateur, and the experimenter. Emphasis has been placed on *how* to use the equipment, not on why it works.

The book is divided into eleven chapters which cover the purposes and general types of signal generators; AM signal generators; marker generators and calibrators; sweep generators; frequency characteristics; output-voltage characteristics; termination, matching, and grounding; principles of sweep-response analysis; how to set up for TV sweep alignment; other signal generator applications; and signal generator maintenance and tests.

The text is lavishly illustrated with photographs of commercially-available equipment and further enhanced by the use of circuit diagrams and scope patterns.

The author is to be commended for the clarity with which he presents his material and the down-to-earth approach which characterizes this entire work. The embryo technician as well as the old timer in the servicing field should derive considerable benefit from this book.

* * *

"TELEVISION TUBE LOCATION GUIDE" by the Sams Staff. Published by *Howard W. Sams & Co., Inc.*, Indianapolis. Price \$2.00. Paper bound.

This is the fourth volume in the current series of "Guides" which have been designed to speed TV troubleshooting and servicing.

The new volume carries tube location diagrams for approximately two hundred different chassis arrangements. To use the manual, the technician locates the make and model number of the set he is servicing and is then referred to the applicable diagram. Each one of these diagrams incorporates a "Tube Failure Check Chart" which lists the symptom and the tube or tubes most likely to cause the failure. A listing of alternate tubes is also included with each chassis on which such substitutions can be made without degrading operation of the receiver.

The index which accompanies this volume covers not only the receiver models covered in this book but also the receivers covered in Vols. 1, 2, and 3 of the series.

* * *

"ELECTRONIC ORGANS" by Robert L. Eby. Published by *Van Kampen Press Inc.*, Wheaton, Ill. 213 pages. Price \$5.00.

With the widespread acceptance of electronic organs in homes, churches, theaters, and nightclubs there has long



THE FISHER HI-LO FILTER SYSTEM • MODEL 50-F

FISHER Hi-Lo Filter System

■ Here it is at last—America's first electronic *sharp cut-off* Filter System. Suppresses turn-table rumble, record scratch and distortion, etc., with the *absolute minimum* loss of frequency response. *Separate* low and high frequency cut-offs. Can be used with *any* tuner, preamplifier, amplifier, etc. No insertion loss. Uniform response 20-20,000 cycles, ± 0.5 db. Self-powered. All-triode. Beautiful plastic cabinet. *Only \$29.95*

FISHER Preamplifier-Equalizer

■ Now, professional record equalization facilities are within the reach of *every* record collector. THE FISHER Model 50-PR, like its big brother (Model 50-C) is beautifully designed and built. *Only \$19.95*

THE FISHER PREAMPLIFIER-EQUALIZER • MODEL 50-PR



New!

PROFESSIONAL
AUDIO
EQUIPMENT AT
LOW
COST!

OUTSTANDING FEATURES

- Independent switches for low-frequency turnover and high frequency roll-off.
- 16 combinations.
- Handles *any* low level magnetic pickup.
- Hum level 60 db below 10 mv input.
- Uniform response 20-20,000 cycles, ± 1 db.
- Two triode stages.
- Full low frequency equalization.
- Output lead any length up to 50 feet.
- Beautiful plastic cabinet, etched brass control panel.
- Completely shielded chassis.
- Built-in AC switch. Jewel indicator light.

Write for full details

FISHER RADIO CORP.

39 EAST 47th STREET • N. Y.

NEW, GUARANTEED 12 VOLT DYNAMOTORS

(D. W. Thomas Engineering Co.)

Ready to Use • Continuous Duty Ratings • Gray Finish

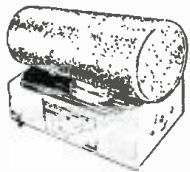

MODEL 1224-1
Output 400V, 350 ma
\$9.95

MODEL 1224-2
Output 600V, 200 ma
\$9.95

Above prices are less base. Add \$6.00 for base box containing starting relays and filters, as shown. (Shipping wt.: Less base, 11 lbs., With base, 13 lbs.)

GENERATOR ALTERNATOR SPECIAL

AC PLUS 12 OR 24 VDC

Two units in one package, each complete in itself: the remarkable centrifugal slip clutch and the generator-alternator. Clutch maintains armature speed of 2400 rpm for drive speeds varying between 2400 and 1200 rpm. Generator-alternator available in two models, 24 v. (NAVY NIA) and 12 v. (College DUB-1). SPECIFY WHICH YOU WANT! Both put out 120 v. 800 cy. 1 ph. 1000 VA. DC output is 2.5 v. 30 A for 12 v. model; 28.5 v. 25 A for 24 v. model. Drive it from engine or electric motor. With diagram and instructions. Excellent used.... **\$5.95** (Shipping wt. 40 lbs.)

RELAYS! RELAYS! RELAYS!

No. 1: Weston Sensitrol is a SPST Normally Open relay that operates directly from a photocell, thermocouple, etc. 10 to 100 mA. See Nov. ad p. 207 for further details. **\$12.95**

No. 2: Barber-Colman Micropositioner AX1Z 27098, dual diagonal, is SPDT both contacts NO. The polarity of applied voltage determines which contact makes. 0.4 vdc (2 ma.) closes B contact, but when you switch positive for negative, the first contact opens and the second one closes. Think of all the tricks possible with this base across a bridge circuit! **\$7.95**

No. 3: G.E. 5 ma. polarized relay is similar in action to above, in a different package. **\$6.95** See Nov. ad p. 207.

No. 4: BS-7 adjustable-sensitivity SPDT. Starts at 1/2 ma. See Nov. ad p. 207. **\$1.95**

No. 5: Dual-Sensitive: Sequence switching. First contacts close at 4 ma., second at 0.2 ma. See Nov. ad p. 207. **95c**

No. 6: 6V or 12V Antenna Relay BK-10 DPDT. No. 30A contacts, plus NC 5A contacts plus small NO contacts for added function. **\$1.75**

No. 7: 6V or 12V starting Relay BS-17. SPDT, 30A intermittent, 20A continuous. **\$1.75**

No. 8: 115V, 60 cy DPST 30A contacts. Normally open. **\$1.45**

COMBINATION PACKAGE: All 8 above relays (total \$35.74 if bought separately). **\$27.50**

MINIATURE 6 VOLT WET BATTERIES



The famous NT-6 Willard 2.4 AH, 6 volt battery. A standard for model control, etc. Plastic case, only 35/8" long, 1 1/16" wide, 23/8" high. Uses standard electrolyte.

NEW, boxed **\$1.49**
Or 4 for **\$5.45**

Charger for 6V batteries. **\$2.45**

AUDIO SUPER-SPECIALS

UNCER Transformers. One for mike to push-pull tubes, flat 30 to 15,000 CPS; other for push-pull output, tapped sec., turns 1:1. In unit for resistors, condensers, etc. **BOTH FOR ONLY .98**
PHASE SPLITTER, or low-level mixer, or hybrid, or push-pull unit. Has 3 windings, each exactly 1:1 to any other, completely flat 100-17,000 CPS. **BRAND NEW, ONLY .69c**

HI-FI HEADSET

Use familiar grooved plastic fibre cones with voice coils in speakers, and padded channels ear mags to obtain spacing for correct acoustical load. Gives most music reproduction, flat far beyond upper and lower limits of audiotape perception. Pair in series has measured impedance of 600 ohms at 1000 cycles, obtained with built-in high quality transformers. Checked out with freshly laminated ear pads. **\$7.95** (Shipping weight, 3 lbs.)

13V to 9V in one volt steps: Tapped transformer, 3 amps out, input 115V, 60 Cy. Use for Model Radiolux or heaters of surplus receiver. **\$1.89**

12-CHANNEL TV FRONT END

Famous "Silver Circle" tuner, with original factory instructions. Use for 2-meter converters, receivers, etc. The TV bargain of the year! Factory rejected for minor damage. Less tubes. **\$1.95 each, 3 for \$5.00** (Shipping wt. each 3 lbs.) Tubes, shafts, and knobs for above. **\$1.25 set, 3 for \$3.00**

ANTENNA MAST SECTIONS, MS-49, 50, 51. 39c
52. New, original packing.

CRYSTAL MICROPHONE GIVEAWAY!

Sensitive hearing aid capsule sealed in compact, flat container with timber terminals. Crisp, clear, high-level output. Ideal for lapels, ties, tuck-aways. Individually tested, guaranteed. **ONLY 98c**

BROADCAST BAND & AERO

MN-26-C Remote Controlled navigational direction finder and communications receiver. Manual DF in any one of three freq. bands, 150 to 1500 KC. 24 V. Self-contained dynamotor supply. Complete installation, including receiver, control box, loop, azimuth control, Left-Right Indicator, plus loop transmiss. sion line, and flex. Shafts. **\$69.50**
BRAND NEW, ORIG. PACK. (Shipping Wt. 75 lbs. Express Collect)

G. L. ELECTRONICS, INC.

905 S. Vermont Ave., Los Angeles 6, Calif.
All Prices F.O.B. Los Angeles, Calif. Buyers Add Sales Tax

GET ON OUR MAILING LIST
"OPEN MONDAY NITES 'TIL NINE"

been a need for a comprehensive guide not only to the commercially-available units but a comparative analysis of such organs.

The text covers a history of electronic organs, and details on organ models made by *Allen, Baldwin, Connsonata, Hammond, Minshall, and Wur-litzer*. Organ attachments such as the *Lowery Organo, Pedal-Vox, Solovox, Haygren Electronic Harp*, and *Glenn-tone* speaker are also illustrated and described.

While the book itself deals with current organ models, separate chapters are devoted to discontinued models, custom-built units, and foreign-made instruments which have found a U.S. market.

This book is not suitable as a servicing manual nor does it supply details for building organs with commercial circuitry. It does, however, provide a compact reference volume for those desiring to pick the right organ for the right job.

* * *

"PRACTICAL TELEVISION ENGINEERING" by Scott Helt. Published by *Rinehart & Company, Inc.*, New York. 730 pages. Price \$7.50. Second Edition.

This is a new and up-to-date version of a definitive work which originally appeared in 1950.

Since the first edition made its appearance the science of television has made tremendous strides technologically. In order to cover these recent developments the author has added new chapters on color, u.h.f., and v.h.f.

Although the major emphasis of the book is on transmitting practices and transmitters, the text also discusses receivers as a link in the system. The author discusses the fundamentals of picture transmission, the cathode-ray

tube, the CR oscillograph, pickup tubes, the sync generator and its associated circuitry, the video amplifier and cathode follower, voltage regulated power supplies, the TV receiver, the camera chain, the transmitter, TV broadcasting techniques, and u.h.f. and color television.

Manufacturing and sales engineers, broadcast engineers, students, and technical workers will all find this book an invaluable aid to a thorough understanding of this booming medium.

Because of the author's clear and complete exposition, this book may be used as a home study text, if desired.

* * *

"HIGH FIDELITY TECHNIQUES" by John H. Newitt. Published by *Rinehart & Co., Inc.*, New York. 487 pages. Price \$7.50.

Although this book has been written for a diversified readership, the author has managed to include information of value and interest to the engineer, home builder of audio gear, service technician, studio personnel, and professionals in the audio field.

The book is divided into twelve chapters dealing with the concept of high fidelity; sound, hearing, listener tests, and acoustics; loudspeakers; re-producer enclosures; crossover networks; distortion; special hi-fi circuits; hi-fi amplifiers and amplifier characteristics; hi-fi receivers; records and record players; magnetic recording; and the custom installation of hi-fi equipment.

By eliminating mathematical treatment and simplifying and clarifying the necessary technical explanations the author has succeeded in presenting his subject in a thoroughly readable style which should appeal to any one of the five categories for whom this work was intended.

-30-

Attending the recent advisory committee meeting for the 1954 Audio Fair-Los Angeles were: William L. Cara, Fair manager (kneeling); and standing left to right, Ed Grigsby, Aitec Lansing Corp. and chairman of WCEMA; Bob Stephens, Stephens Mfg. Corp.; Boyd McKnight, Western vice-president of AES; Ernie Van Leeuwen, Magnetic Recorders Co.; Joe Craig and Frank Koessler, Koessler Sales Co.; Jack Berman, Jack Berman Co.; Harry Shaffer, Hollywood Electronics; George Davis, George Davis Sales Co.; Dick Hastings, Ealy & Hastings; Cap Kierulff, Kierulff Sound Corp. and chairman of the Los Angeles section of the AES; Harry Gamora, Penny-Owsley Music Co.; and Alfred Leonard, Gateway to Music. This year's "Festival of Sound" is scheduled for February 4, 5, and 6 at the Alexandria Hotel in Los Angeles. Five floors have been reserved for registration, display, and exhibition space as compared to the two floors required for the 1953 event which attracted nearly 20,000 visitors. Headquarters of the Fair are at 4245 Normal Ave.



RADIO & TELEVISION NEWS

FREE

TELLS HOW—

WE GUARANTEE

TO TRAIN YOU AND COACH YOU
AT HOME UNTIL YOU GET

YOUR FCC LICENSE

if you have had any practical radio experience—
amateur, Army, Navy, radio repair, or experimenting



TELLS HOW— Our Amazingly Effective JOB-FINDING Service Helps CIRE Students GET BETTER JOBS

GETS AIRLINES JOB

"Due to your Job-Finding Service I have been getting many offers from all over the country, and have taken a job with Capital Airlines in Chicago, as Radio Mechanic."

Harry Clare, 4537 S. Drexel Blvd.,
Chicago, Ill.

GETS CIVIL SERVICE JOB

"I have obtained a position at Wright-Patterson Air Force Base, Dayton, Ohio, as Junior Electronic Equipment Repairman. The Employment Application you prepared for me had a lot to do with my landing this desirable position."

CHARLES E. LOOMIS,
4516 Genessee Ave., Dayton 6, Ohio.

GETS FIVE JOB-OFFERS FROM BROADCAST STATIONS

"Your 'Chief Engineer's Bulletin' is a grand way of obtaining employment for your graduates who have obtained their 1st class license. Since my name has been on the list I have received calls or letters from five stations, in the southern states, and am now employed as Transmitting Engineer on WMAT."
ELMER POWELL, Box 274, Sparta, Tenn.

GETS PUBLIC UTILITIES JOB

"I have secured the position of Radio Technician with the Toledo Edison Company. I want to thank you once more. The help you gave me was much more than would ordinarily be expected—both in obtaining my license and in finding employment."
Norman W. Stokes, Jr., Rt. 11, Box 612, Toledo 7, O.

TELLS HOW— Employers Make JOB OFFERS Like These To Our Graduates Every Month

Letter from nationally-known airplane manufacturer: "We need men with electronic training or experience in radar maintenance to perform operational check-out of radar and other electronic systems starting salary . . . amounting to \$329.33 per month."

HERE'S PROOF FCC LICENSES ARE OFTEN SECURED IN A FEW HOURS OF STUDY WITH OUR COACHING AT HOME IN SPARE TIME

Name and Address	License	Lessons
Lee Worthy, 2210½ Wilshire St., Bakersfield, Cal.	2nd Phone	16
Clifford E. Vogt, Box 1016, Dania, Fla.	1st Phone	20
Francis X. Foerch, 38 Beucler Pl., Bergenfield, N. J.	1st Phone	38
S/Sgt. Ben H. Davis, 317 N. Roosevelt, Lebanon, Ill.	1st Phone	28
Francis X. Foerch, 38 Beucler Pl., Bergenfield, N. J.	1st Phone	38

CARL E. SMITH, E.E., Consulting Engineer, President

Letter from nationally-known Airlines: "We would also appreciate if you would place the following additional advertisement in your bulletin—Wanted—Superintendent of Communications . . . Salary \$666.66 per month."

These are just a few examples of the job offers that come to our office periodically. Some licensed radioham filled each of these jobs. It might have been you!

Ours is the only home study course which supplies FCC-type examinations with all lessons and final tests.

Your FCC Ticket is Recognized in All Radio Fields as Proof of Your Technical Ability



Mail This Card Now
NO POSTAGE REQUIRED

Get All 3 FREE



I want to know how I can get my FCC ticket in a minimum of time. Send me your FREE booklet, "How to Pass FCC License Examinations" (does not cover exams for Amateur License), as well as a sample FCC-type exam and the amazing new booklet, "Money-Making FCC License Information".

Also send me your FREE Booklet "There's Money for You in 2 Way Mobile Radio Servicing."

NAME _____
ADDRESS _____
CITY _____
ZONE _____ STATE _____

CLEVELAND INSTITUTE OF RADIO ELECTRONICS
Desk RN-60, 4900 Euclid Building, Cleveland 3, Ohio
(Address to desk to avoid delay)

SEE OUR AD ON NEXT PAGE

Want To Double Your Pay?

I can train you to pass your FCC License Exams in a minimum of time if you've had any practical radio experience—amateur, Army, Navy, radio servicing, or other. My time-

proven plan can help put you, too, on the road to success. Just fill out the coupon and mail it. I will send you free of charge, a copy of "How To Pass FCC License

Exams," plus a sample FCC-type Exam, and the amazing new booklet, "Money Making FCC License Information."
EDW. H. GUILFORD, Vice President



How To Pass FCC COMMERCIAL RADIO OPERATOR LICENSE EXAMINATIONS



HERE IS YOUR GUARANTEE

Should you fail the FCC commercial license examinations after completing your course, we guarantee to continue your training, without additional cost of any kind, until you successfully obtain your commercial license, provided you first take your examinations within 90 days after completing the course.

IMPORTANT

SEE OTHER SIDE FOR MORE INFORMATION

Brand New - Just Off The Press!

FREE

TO ANY RADIO-TV SERVICEMAN WHO WANTS A BIGGER INCOME!

- Learn how servicing of mobile equipment has become a million dollar business.
- Learn how smart radio servicemen are cashing in.
- Learn how you can get in on the ground floor, what the profits are, every step you take in this expanding market. This is opportunity knocking at your door. Don't miss out.
- Learn what the latest authentic FCC statistics about growing mobile service needs in this country mean to your future in radio servicing.

There's **MONEY FOR YOU** IN 2-WAY MOBILE RADIO SERVICING
Booklet

SERVICING 2-WAY Mobile Radio Systems PAYS BIG MONEY

Mail the Card At Once. Get This Free Booklet too.

If You're in the Armed Forces PLAN NOW for PRESENT and FUTURE SECURITY IN CIVILIAN LIFE

- 1 Use your spare time, NOW, while you are in the armed forces, to prepare for the FCC license examinations, and get your FCC Commercial License.
- 2 Shortly before discharge, use our AMAZINGLY EFFECTIVE JOB-FINDING SERVICE to get your choice of good-pay jobs.

Ex-Navy Man Gets RCA Job

"Since my discharge from the Navy I have been employed by RCA Service Company. Believe it or not, I owe all of my good fortune to your course of instruction, and I can truthfully recommend it to anyone."

CLARENCE JOHNSON, 730 Barron, Redwood City, Calif.



Stromberg-Carlson employs Ex-Army Man "I am now working as a lab technician in the engineering department of Stromberg-Carlson Company. My CIRE course and 2nd 'phone helped a great deal in obtaining this position."
JOHN P. DALEY, P.O. Box 327, Lima, New York

CARL E. SMITH, E.E., Consulting Engineer, President
CLEVELAND INSTITUTE OF RADIO ELECTRONICS
4900 EUCLID BUILDING • CLEVELAND 3, OHIO
Desk RN-60 (Address to desk No. to avoid delay)

TEAR OUT AND MAIL THIS CARD NOW!

Postage Will be Paid by Addressee

BUSINESS REPLY CARD
FIRST CLASS PERMIT No. 8685, Sec. 34.9, P.L. & R. Cleveland, Ohio

Cleveland Institute of Radio Electronics

4900 EUCLID AVENUE

CLEVELAND 3, OHIO

Desk RN-60

No Postage Stamp Necessary If Mailed in the United States



SERVICE HINTS ON MOTOROLA TV SETS

TS-67 CHASSIS

Overheating of flyback transformer.

Overheating of the horizontal output transformer may be caused by the improper setting of the core in the horizontal linearity coil, resulting in a resonant condition in the horizontal linearity circuit.

For proper adjustment, proceed as follows:

1. Replace the fuse temporarily with a milliammeter having a 150-ma. scale.
2. Adjust the horizontal linearity coil slug throughout its range. It will show a peak on the meter of 125 to 130 milliamperes at both ends of its range.

3. Find the point in between where the meter dips to approximately 90 milliamperes with good horizontal linearity. This is the proper setting of the core. If this dip does not occur, it indicates a defective component in the linearity circuit. Check C_{110} (.03 μ f.), C_{120} (.04 μ f.), or the coil itself (L_{60}).

4. Replace the fuse.

TS-216 CHASSIS

Audio buzz.

This may be due to some coupling of vertical scanning frequency onto the grid of the first audio amplifier (V_{121} , 6SN7GT) from the blue plate lead of the vertical output transformer.

The best remedy is to unsolder the blue vertical output transformer plate lead from pin 1 of the 12BH7 vertical output tube. Pull this lead back up to the top of the chassis. Run it on top of the chassis to one of the ground knockout holes near the vertical output tube socket, and dress it through this hole down to the socket. Resolder to pin 1. Be careful to keep the lead away from the audio tubes.

TS-216 & TS-275 CHASSIS

Audio buzz.

The lead connecting the volume control to the grid of the first audio amplifier (pin 1 of V_{121} , 6SN7GT) may be routed too close to the vertical sawtooth forming network consisting of the .05- μ f. condenser, C_{20} , in the TS-216, and C_{207} in the TS-275, and the accompanying peaking resistors. This network is mounted on the terminal strip adjacent to the 4.5-mc. trap.

The remedy is to dress this lead as far as possible away from the sawtooth forming network.

TS-292B, TS-408A & TS-501B CHASSIS

Vertical flutter.

To eliminate this condition when it is due to line voltage variations, change condenser C_7 from 20 μ f. to 10 μ f. (See accompanying diagram

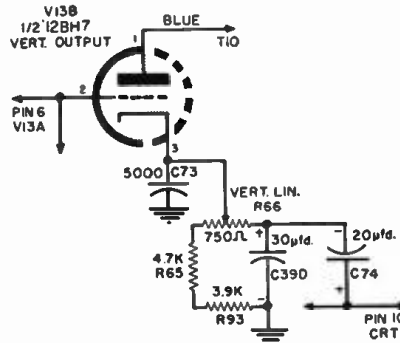

for original circuit.) The new electrolytic should be a 450 volt unit.

TS-324 CHASSIS

Insufficient horizontal sweep width.

If this condition occurs at low line voltages, check to see whether the chassis is equipped with raster corrector magnets. If not, install a pair of these corrector magnets (Motorola part Nos. 1V721584 for the right-hand assembly, and 1V721585 for the left-hand assembly).

Because the chassis uses a metal cone picture tube, it is necessary to use a shield over the magnets to prevent corona. (The Motorola parts include these shields.)

TS-325 & TS-326 CHASSIS

Frequent replacement of 25BQ6.

Frequent replacement of the 25BQ6 horizontal output tube, due to an open heater, may be caused by heater-to-cathode arcing in the 12AX4 tube (V_{215}). This is due to the high-voltage pulse on the 12AX4 damping diode cathode flashing over to the heater.

To remedy this, install a disc-type 5000- μ f. ceramic condenser from pin 7 of the 12AX4 to ground. Use the chassis ground knockout immediately adjacent to pin 7. This condenser will serve to bypass the pulse and prevent breakdown.

TS-325, TS-326 & TS-351 CHASSIS

Vertical bars at left of picture.

This may be due to a failure of the damping resistor across the horizontal deflection coil in replacement yokes. Check this resistor to see whether it has a 1/2-watt rating instead of the prescribed 1 watt. If so, replace it with a 1-watt unit. The smaller resistor apparently will not withstand the high-voltage pulse and breaks down.

Yoke ringing.

Ringing (white bars following black lines) can result if the value of the shunt condenser, C_{25} , across one of the horizontal deflection yoke coils varies too much from optimum. The 27- μ f.

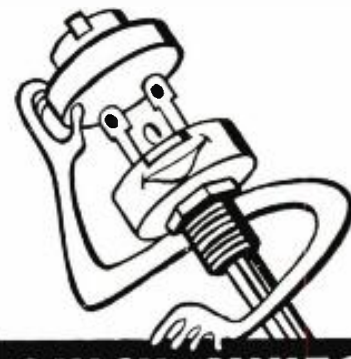

QUICK SWITCH

FASTATCH*

converts controls to switch-types in seconds!

What a life-saver Fastatch can be when you need a TV-AM-FM switch-type control in a hurry. SNAP, it's on in seconds! Saves you valuable bench working time — no ears to bend, no loose parts. Fastatch switch units are perfectly matched to famous Centralab Blue Shaft controls.

Type KB Fastatch switches give you service flexibility unmatched in any other line.

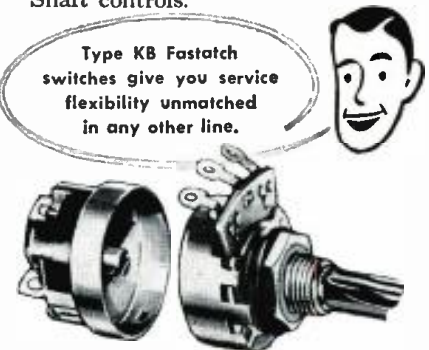

Fastatch converts any plain type control with blue label on back to switch type. Available in 3 styles: SPST, SPDT and universal DPST. Rated at 5 amps — 125 v.a.c.; 1/2 amp — 125 v.d.c.; 12 amps — 12 v.d.c. Underwriter's approved.

When you're stocking Fastatch units, be sure to get a supply of Blue Shafts too. Available from 500 ohms to 10 megs in a wide variety of tapers and tapped units. You can buy 'em singly or in handy kits. Order this Centralab time-saving combination NOW — your distributor has complete stocks.

Centralab

*Trademark

CENTRALAB
A Division of Globe-Union Inc.
910-A.E. Keefe Ave., Milwaukee 1, Wis.
Please send Catalog 28 with additional technical data on Blue Shaft Fastatch switches.

Name.....
Firm.....
Address.....
City..... Zone..... State.....



irish BRAND OFFERS YOU A SOUND RECORDING TAPE TO FIT THE PERFORMANCE REQUIREMENTS OF YOUR TAPE RECORDER

Not all tape recorders are alike. A professional instrument intended for high quality music reproduction will perform differently than a portable unit intended for home or office use. Whereas one will record and reproduce from 30 to beyond 15,000 cycles per second, the less costly unit may be limited to a range from 100 to 7000 cps. or less.

Obviously, there is no advantage in using a wide response tape with a limited-response recorder! And there is a definite disadvantage . . .

WHY PAY MORE FOR WIDER RESPONSE WITHOUT GETTING ANYTHING IN RETURN?

Until the development of IRISH Brown Band, users of sub-professional tape recorders had no choice! But IRISH Brown Band was designed specifically for such recorders. THERE HAS BEEN NO SACRIFICE IN QUALITY . . . IRISH Brown Band has been specially developed to reproduce with true fidelity the frequency range between 100 and 8000 cycles.

The considerable savings in production costs now enables you to buy high quality, plastic tape at a price, which up to now, could only buy ordinary paper tape!

1200 feet, plastic tape, on plastic reel\$3.75

For professional recording on equipment with wide frequency response, your best tape buy is IRISH GREEN BAND NO. 211, the professional super-sensitive, wide-range recording tape that is used in broadcast stations and recording studios throughout the industry.

1200 feet on plastic reel.....\$5.50

2400 feet on metal reel.....12.85

One day you will surely use IRISH
. . . write direct to factory for a free
sample test reel today.



At all leading radio parts distributors

ORRADIO INDUSTRIES, INC.

OPELIKA 6, ALABAMA

EXPORT DIVISION: Morhan Exporting Corp., New York, N. Y.

GET INTO ELECTRONICS

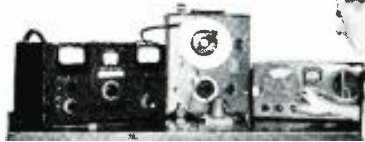

You can enter this uncrowded, interesting field. Defense expansion, new developments demand trained specialists. Study all phases radio & electronics theory and practice: TV; FM; broadcasting; servicing; aviation, marine, police radio. 18-month course. Graduates in demand by major companies. U.S. or equivalent required. Begin Jan., March, June, Sept. Campus life. Write for catalog.

VALPARAISO TECHNICAL INSTITUTE
Dept. RD Valparaiso, Indiana

MORE CASH

Att.: Schools, Labs, Hams!

Cash in on your surplus
Radio Parts & Equipment!
We pay more—or trade for
something you really need.
TV Sets, Mobile Equipment
Available for Trade. Write
Now!

HARJO SALES CO.
4109 Burbank Blvd.
Burbank, Calif. Cable HARJO

ARKAY
world's finest radio kits
Write for free Brochure
RADIO KITS, INC., 120 Cedar St., N. Y. 6

condenser used in earlier yokes is too low for present distributed capacity yokes.

If ringing is encountered, replace the condenser with a 50- or 56- μ fd., 2000-volt unit.

Beat interference.

To decrease beat-type interference, appearing as either a stippled effect or diagonal lines, move the high side of R_{225} , the 5600-ohm detector load resistor, to the junction of L_{210} and L_{211} (pin 3 on the bottom of T_{201}).

No a.g.c.

This defect is characterized by either an overload condition or loss of sensitivity, and may be due to faulty 6CB6 i.f. tubes having a high-resistance leakage between the grid and the heater. In many cases, the defective tubes will show such a leakage when measured cold with a v.t.v.m.

Audio beat on channel 7.

To correct this condition, do the following:

1. Replace the shielded contrast lead with an unshielded lead.
2. The shielded volume control lead is originally routed between the 9-ter-

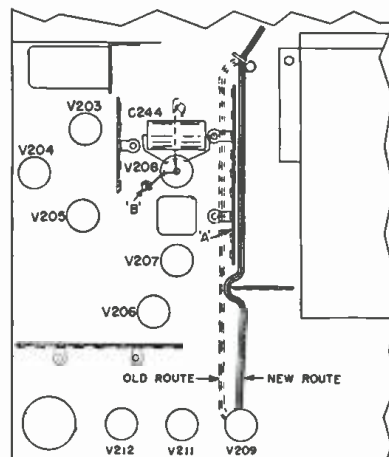

minial strip ("A" on accompanying diagram) and the audio i.f. strip. Reroute this lead to the other side of the terminal strip to minimize the 4.5-mc. pickup in the lead.

3. The ground lead from the center pin of the ratio detector socket (V_{205} , 6AL5) is originally dressed over a 10- μ fd. electrolytic (C_{241}) to chassis ground knockout. Move the lead from this knockout to the knockout near the tube socket on the video i.f. side ("B" on accompanying diagram).

Audio buzz.

This may be due to pickup of the vertical scanning frequency by the grid of the first audio tube, V_{204} , a 6SN7GT. This occurs if the lead connected from pins 6 and 2 of the 12BH7 vertical tube (V_{212}) to condenser C_{255} (.047 μ fd.) is dressed too close to pin 1 of V_{204} .

Redress this lead as far as possible from pin 1 of V_{204} .

Sync buzz.

In early versions of this chassis series, the grid resistor of the 6AH6 video amplifier is returned to ground in the fringe position and also the suburban positions of the area selector

NO INTEREST!!

Buy on our radically new
Time Payment Plan

NO CARRYING CHARGES!!



Measures 6 1/4" x 9 1/2" x 4 1/2"

Superior's new
Model 670-A

SUPER METER

A COMBINATION VOLT-OHM MILLIAMMETER PLUS
CAPACITY REACTANCE INDUCTANCE AND DECIBEL MEASUREMENTS

SPECIFICATIONS:

D.C. VOLTS: 0 to 7.5/15/75/150/750/1,500/7,500 Volts
A.C. VOLTS: 0 to 15/30/150/300/1,500/3,000 Volts
OUTPUT VOLTS: 0 to 15/30/150/300/1,500 3,000 Volts
D.C. CURRENT: 0 to 1.5/15/150 Ma. 0 to 1.5/15 Amperes
RESISTANCE: 0 to 1,000/100,000 Ohms 0 to 10 Megohms
CAPACITY: .001 to 1 Mfd. 1 to 50 Mfd. (Quality test for electrolytics)
REACTANCE: 50 to 2,500 Ohms, 2,500 Ohms to 2.5 Megohms
INDUCTANCE: .15 to 7 Henries 7 to 7,000 Henries
DECIBELS: -6 to +18 +14 to +38 +34 to +58

ADDED FEATURE:

The Model 670-A includes a special **GOOD-BAD** scale for checking the quality of electrolytic condensers at a test potential of 150 Volts.

The Model 670-A comes housed in a rugged, crackle-finished steel cabinet complete with test leads and operating instructions.

\$28⁴⁰
NET



Superior's new
Model TV-11

TUBE TESTER

SPECIFICATIONS:

- ★ Tests all tubes including 4, 5, 6, 7, Octal, Lock-in, Peanut, Bantam, Hearing Aid, Thyatron, Miniatures, Sub-Miniatures, Novals, Sub-minars, Proximity fuse types, etc.
- ★ Uses the new self-cleaning Lever Action Switches for individual element testing. Because all elements are numbered according to pin-number in the RMA base numbering system, the user can instantly identify which element is under test. Tubes having tapped filaments and tubes with filaments terminating in more than one pin are truly tested with the Model TV-11 as any of the pins may be placed in the neutral position when necessary.
- ★ The Model TV-11 does not use any combination type sockets. Instead individual sockets are used for each type of tube. Thus it is impossible

- to damage a tube by inserting it in the wrong socket.
- ★ Free-moving built-in roll chart provides complete data for all tubes.
- ★ Newly designed Line Voltage Control compensates for variation of any Line Voltage between 105 Volts and 130 Volts.
- ★ **NOISE TEST:** Phono-jack on front panel for plugging in either phones or external amplifier will detect microphonic tubes or noise due to faulty elements and loose internal connections.

The model TV-11 operates on 105-130 Volt 50 Cycles A.C. Comes housed in a beautiful hand-rubbed oak cabinet complete with portable cover

\$47⁵⁰
NET

EXTRA SERVICE—The Model TV-11 may be used as an extremely sensitive Condenser Leakage Checker. A relaxation type oscil-

lator incorporated in this model will detect leakages even when the frequency is one per minute.



The Model 660-A comes complete with coaxial cable test lead and instructions.

Superior's New Model 660-A AN AC OPERATED
SIGNAL GENERATOR

PROVIDES COMPLETE COVERAGE for AM-FM & TV Alignment

SPECIFICATIONS:

• Generates Radio Frequencies from 100 Kilocycles to 50 Megacycles on fundamentals and from 50 Megacycles to 220 Megacycles on powerful harmonics. • Accuracy and Stability are assured by the use of permeability trimmed Hi-Q coils. • R.F. available separately or modulated by the internal audio oscillator. — Built in 400 cycle sine wave audio oscillator used to modulate the R.F. signal also available separately for audio testing of receivers, amplifiers, hard of hearing aids, etc. • R.F. Oscillator Circuit: A

high transconductance heptode is used as an R.F. oscillator, mixer and amplifier. Modulation is effected by electron coupling in the mixer section thus isolating the oscillator from load changes and affording high stability. • A.F. Oscillator Circuit: A high transconductance heptode connected as a high- μ triode is used as an audio oscillator in a High-C Colpitts Circuit. The output (over 1 Volt) is nearly pure sine wave. • Attenuator: A 5 step ladder type of attenuator is used.

Tubes used: 1—6BE6 as R.F. Oscillator, mixer and amplifier. 1—6BE6 as Audio Oscillator. 1—6H6 as Power Rectifier.

\$42⁹⁵
NET

MOSS ELECTRONIC DISTRIBUTING CO., INC.
Dept. B-89, 3849 Tenth Ave., New York 34, N. Y.

Please send me the units checked. I am enclosing the down payment with order and agree to pay the monthly balance as shown. It is understood there will be no carrying interest or any other charges provided I send my monthly payments when due. It is further understood that should I fail to make payment when due, the full unpaid balance shall become immediately due and payable.

Name.....
Address.....
City..... Zone..... State.....

- MODEL 670-A..... Total Price \$28.40 \$7.40 down payment. Balance \$3.50 monthly for 6 months.
- MODEL TV-11..... Total Price \$47.50 \$11.50 down payment. Balance \$5.00 monthly for 6 months.
- MODEL 660-A..... Total Price \$42.95 \$12.95 down payment. Balance \$5.00 monthly for 6 months.
- I enclose \$..... as down payment.
- Ship C.O.D. for the down payment.

THE American IDEA



"To find and follow the better way" . . . Out of the vision of Dr. George Ellery Hale came the great "American Idea" that resulted in the creation of the "Glass Giant of Palomar"—world's largest telescope—to gather new light from the farthest stars for the searching eye of science.

With all the "American Idea" is by directed effort and applied know-how to continue to lead in bringing you electronic products of the highest quality.

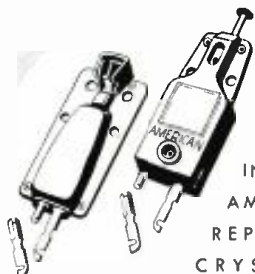

INSIST ON
AMERICAN
REPLACEMENT
CRYSTAL
CARTRIDGES

Send for FREE catalog 46



American microphone co.

370 South Fair Oaks Ave. • Pasadena, 1, Calif.

switch. The tendency on the part of a viewer located 30 or 40 miles from a transmitter is to operate the receiver with the area selector switch in the suburban position. Unfortunately, at this distance, signal level is quite often high enough to cause the video amplifier to limit with attendant sync buzz.

To remedy this condition, rewire the video amplifier grid resistor (R_{22} , 1 megohm) return, in the suburban position of the switch, to the cathode of the first audio amplifier.

TS-410A CHASSIS

Horizontal overdrive and fold-over.

To eliminate this condition, do the following:

Change R_{22} (4700 ohms) to 6800 ohms; R_{23} (4700 ohms) to 5600 ohms;

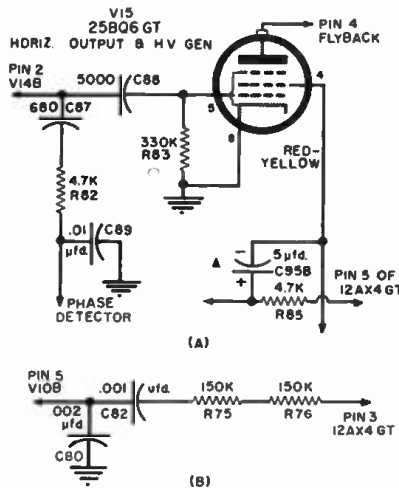

C_{80} (.002 μ fd.) to 4700 μ fd. (See accompanying diagram for original circuit.)

Visible retrace lines.

To improve retrace blanking, change R_{22} (3300 ohms) to 1800 ohms, and R_{23} (1800 ohms) to 3300 ohms. These resistors are in the plate circuit (pin 6) of the 12BH7 vertical blocking oscillator tube. This will increase the blanking pulse at the grid of the picture tube.

High-voltage flashover.

Add a 5000- μ fd., 2000-volt condenser from the picture tube focusing anode (blue lead) to chassis, to prevent high-voltage flashover within the picture tube. Change condensers C_{21} and C_{23} (5000 μ fd.) to condensers with a 2000-volt rating to eliminate high-voltage flash-over within the vertical output tube and the damping diode respectively.

U.H.F. TUNER TT-19A, TT-27MA, etc.

Oscillator drift.

To prevent oscillator drift during warmup, add a 19- μ fd. condenser between pin 2 of the 6AF4 oscillator tube and the oscillator pipe.

TS-325 & TS-351 CHASSIS

Audio buzz.

This may occur if the lead connecting the arm of the vertical hold control to the blue blocking oscillator transformer (T_{212}) lead is carelessly dressed where it passes audio tubes, so

PREMAX

For That Extra Margin
of Safety . . .

Copper Plated Ground Rods

Bring Extra Profits

Simple! Practical! Low-priced! Of smooth-drawn steel, pointed for easy driving and copper-plated for rust prevention and to assure clean electrical contact. Available in four popular styles, in 4', 6' and 8' lengths, $\frac{3}{8}$ ", $\frac{1}{2}$ " and $\frac{5}{8}$ " diameters. Send for special Ground Rod Bulletin and prices.



PREMAX PRODUCTS

Division of Chisholm-Ryder Co., Inc.

5323 HIGHLAND AVE., NIAGARA FALLS, N. Y.

AC-DC TELEVISION SETS

7" RAYTHEON (270X21) . . . HERE'S YOUR EXTRA SET FOR HOME OR OFFICE! COMPLETE OPERATING RECEIVER, 30 DAY GUARANTEE on all 20 tubes, including 7AP4. Beautiful mahogany veneer cabinet. Sound and picture OK, needs some adjusting. Excellent used condition. 113V. 17"X16"X10 1/2". Shipped Exp. . . . **\$29.95** WHILE THEY LAST.

PHILCO TV TURRET TUNER (P1 276-3109, less coil strips, for '38 & '40 models) . . . \$1.49
 ABOVE TUNER with 4 socket wires, 4P strips . . . 1.98
 PHILCO 3 MIN. SOCKET RE STRIP—containing over \$4.00 worth of Resistors, Condensers, etc.59
 BLACK HARD RUBBER PANELS 5 1/2"X2" thick 9"X12"89; 12"X12" . . . \$1.15; 12"X18" . . . 1.65
 12"X21" . . . \$2.15; 18"X18" . . . \$2.39; 18"X24" . . . 2.98
 EXPERIMENTAL TUBES for Test, Research, etc. Phil. tested. Kit of 40 ass'd, revg. types 1.98
 GD-60 (G-E) RADIO DIAL STRIPS, Tune & Vol.25
 ELECTRICAL RUBBER TAPE (T-1924) 3/4"X1 1/2" (6" roll) 19c6 1.00
 60" TV DEFLECTION YOKE for 12" & 16" tubes 1.29



MOTOR SPECIALS!— 1/17 H.P. G-E MOTOR (Type SD), 1725 RPM, 110VDC, 7 amp. Dule, 3/4" shaft, O.D. 3/4"X5 1/2". \$3.95
 6V. DC MOTOR (Delco), Dashed proof cased, 1/2" shaft, 2740 RPM, 2 1/2" x4" (shpg. wt. 4 lbs.) \$2.95

DELCO DC MOTOR (21592818), 27V, 5400 RPM, 1 1/2" shaft, 1.5A., 4 1/2" dia., O.D. 2 1/2"X4" . . . \$2.95
 1 40 H.P. AC MOTOR (Robins & Myer), 113V, 1420 RPM, 5 1/4" shaft, O.D. 3 1/4"X4 1/2". With starting condenser & switch (6 lbs.) . . . \$4.95

W-110B ARMY FIELD WIRE . . . coils 100.
 400 ft. \$1.25 FT.
 13V. PILOT BULBS 2 1/2"X1 1/2" base, Box of 10 5 .89
 6V. AC-DC PLUNGER SOLENOID (2"X1 1/2"X1 1/2", 1 inch travel) ea. 98c; 6 \$5.00
 BLOWER WHEEL & HOUSING . . . for assbly, with any small motor. Mounted bakelite housing. Type 2190, 1 1/2" dia. 98c set. Type 2151, 2" dia. set 1.95
 ROTARY BALL-BEARING SWIVEL ASSEMBLY. Designed for TV TABLE SETS; perfect for HEAVY CHASSIS SERVICING & ROTARY DISPLAY. Whole Rugged hardware incl. between 13"O.D. & 1 1/2" Masonite plates. \$5.95
 HS-33 HEADSETS . . . leather band. Less phn. \$2.95
 HS-30 PHONES with transformer, 8000 ohms. 2.49

!!SUPER \$\$\$ SAVINGS!! . . . with the \$395 NEW "COMBO" R A D I O . . . ELECTRONICS PARTS KIT . . . Check full of SWITCHES, CONTROLS, RESISTORS, CONDENSERS, WIRE, SOCKETS, PHOTOFACTS, TV PARTS & DIAGRAMS, ETC., ETC. (shpg. wt. 20 lbs.)

"DIRECT FACTORY SPEAKER REPAIRS SINCE 1927" Min. order \$3.00. 20% deposit req. on all C.O.D.'s. Please add sufficient postage—excess refunded.

LEOTONE RADIO CORP.
 67 Dey Street
 New York 7, N. Y.

RADIO & TELEVISION NEWS

that one or the other of these tube grids can have the vertical scanning frequency impressed on it.

To remedy this, redress this lead away from the audio grids. —30—

The "Basket Chassis"

(Continued from page 43)

lengths. Round head screws were used, but hinder head screws probably are preferable.

Feedthrough leads should be protected by forcing 1/4-inch rubber grommets into the mesh at the feedthrough point. This method was used to protect the a.c. input and power output cables on the power supply.

Adjustment

After constructing the power supply, operate this unit without connection to the transmitter. If there are no indications of overheating it is probable that the unit has been correctly wired. If a voltmeter is available this conclusion can be verified by measuring output voltages. These may measure slightly high since load currents are not being drawn. A d.c. output of 440 volts was measured for the power supply shown.

After connecting the transmitter to the power supply wait for about a minute for the tube to warm up. Without the antenna connected and with the proper plate coil in the socket, press the key and rotate the tuning condenser, C_4 , until oscillation is indicated by a dip in the plate current reading.

This transmitter was designed for use with a simple voltage feed antenna. This type of antenna consists of a single wire cut to the operating frequency. The approximate lengths are 260 feet for the 1.8 mc. band, 126 feet for the 3.5 mc. band, and 66 feet for the 7 mc. band.

The antenna can now be connected, and the key closed. Once more rotate the tuning condenser until the plate current dips. With maximum coupling this dip will be slight. To increase coupling move the tap toward the plate end of the coil. To decrease coupling move the tap away from the plate end of the coil. The tap connection is made by carefully sanding away the enamel insulation from the turns and soldering the tap to a suitable turn. Be careful not to short adjacent turns.

Power output is dependent upon applied voltage and the ability of the transmitter to accept loading. Excessive loading may stop oscillations. This limitation is dependent upon circuit components and arrangement. After loading and tuning, key the transmitter to be sure that the circuit keys well. If keying is poor decrease antenna coupling slightly. An output of 15 to 20 watts can be expected in most cases. The unit shown draws approximately 15 milliamperes unloaded and 60 milliamperes with the antenna attached. —30—

January, 1954

MAKE MORE MONEY ON SERVICE!

TELEVISION • RADIO • ELECTRONIC



Learn to handle ANY job easier, better and lots FASTER this modern professional way!

ONLY \$12 FOR THE COMPLETE TRAINING *You Save \$1.25*

THESE two big, fact-packed Ghirardi training books make it easy for you to become expert on all types of home radio and television receiver service—at absolute minimum cost!

Ask the men who already have good-pay jobs! They'll tell you that Ghirardi training is the finest—AT ANY PRICE—because it is so outstandingly complete, and because it makes even the

toughest subjects so easy to understand.

Each of these two books is entirely new, completely modern in every respect—NOT a re-hash of old, outmoded material. Together, they form a complete service library written so you can easily understand every word—and designed to serve either as a complete training course or as a handy reference for experienced servicemen who want to look up puzzling jobs or develop new and faster methods.



Radio and Television Receiver **CIRCUITRY AND OPERATION**

By Ghirardi and Johnson
669 pages, 417 helpful illustrations

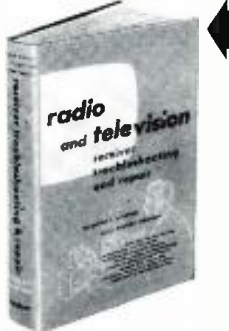

Radio and Television Receiver **TROUBLESHOOTING AND REPAIR**

By Ghirardi and Johnson
822 pages, 417 clear illustrations

Learn all about Circuits... AND WATCH SERVICE "HEADACHES" DISAPPEAR

Years of experience plus hundreds of talks with service technicians proved to Mr. Ghirardi the need for a book that got right down to earth in explaining the basic circuits and operation of modern radio and television receivers. Radio & Television Receiver Circuitry and Operation is the result. Backed by what you can learn from it, you'll find that 9 out of 10 service jobs are tremendously simplified. You'll work faster with less testing—and make more money in the bargain! Guesswork is eliminated.

Starting with AM and FM processes and characteristics, the book

progresses to a complete understanding of basic circuits, how they operate, how to recognize them quickly and what is likely to go wrong with them. By making it easy for you to understand each circuit and its relation to other circuits, the book helps you go right to the seat of trouble in far less time. You'll know what different trouble symptoms mean—and you'll know how to repair troubles lots faster and more efficiently.

Sold separately for \$6.50. Try it for 10 days on our FREE examination offer.

Complete Training in MODERN, PROFESSIONAL SERVICE METHODS

This big book makes the tough service jobs easy, makes the easy ones a cinch!

Actually, Radio & Television Receiver TROUBLESHOOTING AND REPAIR is a complete guide to modern professional service methods.

First you get a full analysis of components, their functions, their troubles and their remedies. Next you learn modern troubleshooting methods—from "static" tests to dynamic signal tracing and injection techniques. You learn basic procedures and how to interpret performance data. Four big chapters show how to repair Television, FM and AM receivers in less time. You'll learn how a glance at a TV set may quickly tell you what is wrong. Special hard-to-fix service problems are explained. Puzzling "intermittent" troubles and their remedies are clearly outlined. Step-by-step service procedure charts

demonstrate many operations almost at a glance. In short, from the simplest troubles to the most difficult ones, nothing has been omitted—nothing has been condensed. Everything is carefully explained and the entire book is fully indexed so you can find exactly what you want in a jiffy.

Read it 10 days FREE! See for yourself how this great book can save your way for bigger pay. Sold separately for \$6.75. Save money by ordering special combination offer.



SPECIAL money-saving OFFER!

Save \$1.25 by ordering both of the above big books. Make your service library complete!

Dept. RN-14, Rinehart Books, Inc., Technical Division, 232 Madison Ave., New York 16, N. Y.

Send books below for 10-day FREE EXAMINATION. In 10 days, I will either remit price as indicated or return books postpaid and owe you nothing.

Check here to order books singly:

Radio & TV Receiver **CIRCUITRY & OPERATION** (Price \$6.50 separately)

Radio & TV Receiver **TROUBLESHOOTING & REPAIR** (Price \$6.75 separately)

Check here for MONEY SAVING COMBINATION **Save \$1.25!**

Both of the above big books at the special price of only \$12.00 for the two, (regular price \$13.25)—you save \$1.25! Payable at the rate of \$3 after 10 days if you decide to keep books and \$3 a month thereafter until the total of \$12 has been paid.

Name

Address

City, Zone, State

OUTSIDE U. S. A.—\$7.25 for TROUBLESHOOTING & REPAIR book; \$7.00 for CIRCUITRY & OPERATION; \$13.00 for both books. Cash with order only. Money refunded if you return books in 10 days.

Windsor TUBES

RADIO & TV RECEIVING

TESTED and
GUARANTEED
for PEAK
PERFORMANCE!

TO MERIT YOUR CONFIDENCE — to insure your satisfaction — Every tube we ship has been tested in a radio or TV set for PEAK PERFORMANCE. Each tube is attractively packaged in individual carton — and, each WINDSOR Tube you buy carries the full RTMA GUARANTEE!

Type	Each	Type	Each	Type	Each	Type	Each
1A7GT	.67	1U5	.51	6AU6	.47	6J5GT	.44
1B3GT	.69	1X2A	.74	6AV5	.85	6J6	.68
1C6	1.06	2A7	.74	6AV6	.41	6J7	.70
1E7GT	1.09	2X2	1.43	6AX4	.72	6K6GT	.45
1H5GT	.51	3L4	.76	6B8G	.93	6K7	.70
1H6	.93	3Q4	.66	6BA6	.50	6L6G	.88
1J6	.93	3Q5GT	.72	6BA7	.66	6L6GA	.88
1L4	.63	35A	.61	6BC5	.58	6Q7GT	.55
1L6	.66	3V4	.62	6BD5GT	.98	6S4	.51
1LA4	.82	5R4GY	1.00	6BD6	.54	6S4GT	.51
1LA6	.80	5U4G	.44	6BE6	.51	6S8GT	.75
1LB4	.82	5V4G	.83	6BF5	.66	6SA7GT	.57
1LC5	.80	5Y3G	.37	6BF6	.43	6SC7	.63
1LC6	.80	5Y3GT	.32	6BG6G	1.47	6SD7	.55
1LD5	.80	5Y4G	.43	6BH6	.63	6SF5GT	.66
1LE3	.80	6A8GT	.68	6BJ6	.53	6SH7GT	.52
1LG5	.80	6AB4	.51	6BK5	.76	6SJ7GT	.52
1LH4	.80	6AC5GT	.82	6BK7	.97	6SK7GT	.55
1LN5	.80	6AG5	.59	6BL7GT	.94	6SL7GT	.68
1NSGT	.63	6AH4	.68	6BN6	.98	6SN7GT	.59
1P5	.76	6AK5	1.05	6BQ6GT	.98	6SQ7GT	.46
1Q5	.72	6AL5	.44	6BQ7	.92	6T8	.85
1R4	.85	6AQ5	.51	6BZ7	1.09	6U8	.86
1R5	.62	6AQ6	.47	6C4	.41	6V3	1.09
1S4	.67	6AQ7	.75	6CB6	.58	6V6GT	.51
1S5	.52	6AR5	.42	6CD6G	2.04	6W4GT	.50
1T4	.62	6AS5	.55	6D6	.63	6W6GT	.63
1T5GT	.78	6AT6	.42	6E5	.72	6X4	.37
1U4	.61	6AU5GT	.85	6F5GT	.54	6X5GT	.36



Type	Each	Type	Each
6Y6G	.64	12BA7	.66
7A4/XXL	.57	12BD6	.51
7A5	.70	12BE6	.52
7A6	.57	12BH7	.69
7A7	.58	12BY7	.77
7A8	.56	12J5GT	.48
7AD7	1.05	12SA7GT	.57
7AF7	.63	12SK7GT	.55
7AG7	.65	12SL7GT	.67
7AH7	.65	12SN7GT	.59
7AJ7	.70	12SQ7GT	.46
7A8	.54	14A7	.58
7B5	.51	14AF7	.68
7B6	.52	14B6	.50
7B7	.58	14C5	.85
7C4	1.05	14C7	.70
7C5	.56	14E6	.70
7C6	.50	14E7	.85
7C7	.58	14F7	.69
7E5	.85	14F8	.99
7E6	.65	14J7	.85
7E7	.85	14N7	.75
7F7	.69	14Q7	.62
7F8	.97	14R7	.85
7G7	.85	14S7	.80
7H7	.61	19B6G	1.53
7J7	.85	19T8	.87
7K7	.85	25BQ6GT	.98
7L7	.85	25L6GT	.53
7N7	.62	25W4GT	.53
7Q7	.62	25Z6GT	.46
7R7	.70	35A5	.55
7S7	.90	35B5	.53
7V7	.92	35C5	.53
7X6	.62	35L6GT	.52
7Y4	.45	35W4	.33
7Z4	.50	35Z5GT	.33
12AT6	.53	50A5	.55
12A7	.75	50B5	.52
12AU6	.47	50C5	.52
12AU7	.58	50L6GT	.52
12AV6	.41	117Z3	.43
12AV7	.87		
12AX4	.72		
12AX7	.67		
12AY7	2.15		
12BA6	.50		

FREE! WINDSOR TUBE CADDY



The most practical Service-Aid ever designed for the radio and TV repairman. This ideal television carry-all now offered free with every purchase of \$160.00 or accumulated purchases totalling \$160.00 within 90 days. (You get caddy credit memo with each purchase.)

- Carries approximately 125 tubes including meters and tools.
- 16 3/4 inches long x 8 1/2 inches wide x 1 3/4 inches high.
- Weighs only nine pounds.
- Ruggedly constructed with heavy leatherette covering, strong plastic handle, nickel plated hardware, and reinforced with metal clamps.

Windsor Tube Caddy may also be purchased outright for \$14.95.

DON'T MISS THIS SENSATIONAL OFFER!

WRITE FOR Additional Tube Types and Prices. We also stock Special Purpose and Transmitting Tubes at similar savings! Dept. N-1.

25% DEPOSIT with Order. All Merchandise F.O.B. New York City. For orders less than \$10, add \$1 handling cost. Deduct 2% if full remittance accompanies order. All merchandise subject to prior sale and price change without notice.

Windsor ELECTRONIC TUBE CO.

1515-N SHEEPSHEAD BAY ROAD, BROOKLYN 35, N. Y.

RECORDING TAPE (Plastic Base) 40% OFF (NEW)

WASHINGTON, D. C. WHERE ELSE WOULD THERE BE MORE RED A TAPE?

- 1200 ft. plastic tape with plastic reel included.
- Each reel individually boxed.
- Choice of nationally famous top quality brands such as:
 - Wohler (2400) 3.20; Heeves (SPN-12) 3.20; Audio (1251) 3.25; Scotch (111-A) 3.25; Panacoustic (711-A) 3.25; Irish, Professional grade (211) RPV 3.20.
- FREE! A 7.95 tape carrying case included with purchase of 12 new tapes!

USED RECORDING TAPE (PLASTIC BASE)

1.99 for 7"—1200 foot
.99 for 5"—600 foot
.59 for 4"—300 foot
.29 for 3"—150 foot
Plastic reels included with all above sizes

New empty plastic reels in boxes for easy labeling. 3" 10c; 4" 22c; 5" 24c; 7" 30c; 7" Professional reel (2 1/2" hub) 45c ea. EMPTY BOXES: 3" 3c; 4" 5c; 5" 5c; 7" 10c ea.

We carry new recorders, recording blanks, tape, tape recorders, etc. at large savings. PLEASE INCLUDE SUFFICIENT POSTAGE.

COMMISSIONED ELECTRONICS CO.
2503 Champlain St. N.W., Washington 9, D. C.

SPEAKER RECONING

Complete line Cones, Spiders, Rings and Voice Coils. Custom Built Voice Coils. Low prices. Write for Parts List and Reconing information.

WESTERN ELECTRONICS CO.
3164 West Colfax Denver 4, Colo.

TELEVISION

PREPARE FOR A GOOD JOB!
BROADCAST ENGINEER
COMMERCIAL OPERATOR (CODE)
RADIO SERVICING

Television Servicing

(Approved for Veterans)
SEND FOR FREE LITERATURE
BALTIMORE TECHNICAL INSTITUTE
1425 EUTAW PLACE, BALT. 17, MD.

Karlson Enclosure (Continued from page 60)

very rapidly with the result that at 30 cycles fundamental coupling is virtually non-existent. Note also that a serious dip occurs here due to cabinet resonance in the region from 120-350 cycles, the region of maximum voice power. This dip with the consequent adjacent peaks causes a considerable amount of overhang which is typical of many such enclosures. The cabinet tested was one of a standard commercial design with a volume of approximately 6 cu. ft. The impedance curve of the same speaker in the Karlson enclosure (Fig. 8) indicates a decided change from the previous tests. First of all, note the complete absence of any indication of a single mechanical resonance curve as is evidenced in the previous tests. The curve resulting from these tests is very similar to that found with very large exponential horns, and is also characteristic of almost all exponentially tapered terminations which are used in achieving a flat response over extraordinarily wide bandwidths. As shown in Fig. 9, this type of curve is peculiar to a special case in the normal resonance formula, and occurs near the point of optimum critical damping at which the resonant frequency of a system is zero. This optimum value occurs only in horns or other distributed parameter devices when they approach an infinite size. Since optimum coupling can only be achieved in a device having distributed parameters and its losses primarily due to radiation resistance, this curve therefore represents an almost ideal performance relative to its size. The alternate peaks and dips shown do cause some variation in the frequency response. Olson states that a deviation of impedance on the order of 6:1 is required to change the acoustical output 2 db, so it is obvious that the departure from the mean due to the largest deviation shown is a fraction of a db. It is accepted that 2 db is the minimum difference that the ear can detect, so this minor departure from the ideal is considered acceptable. An important characteristic of such curves is the non-harmonic relationship of the peaks and valleys therein. Thus for a note at 30 cycles no reinforcement is given to the second harmonic at 60 cycles or the third harmonic at 90 cycles. This characteristic still further improves the cleanness of the bass response. It is estimated that no more than 2% harmonic distortion occurs at 30 cycles in the Karlson enclosure. When the impedance curve of this enclosure is normalized to compensate for the obvious dip in the speaker impedance, it is seen that the matching and transition from the lowest to the highest frequencies occurs with extreme smoothness and continuity, thus indicating the value of the

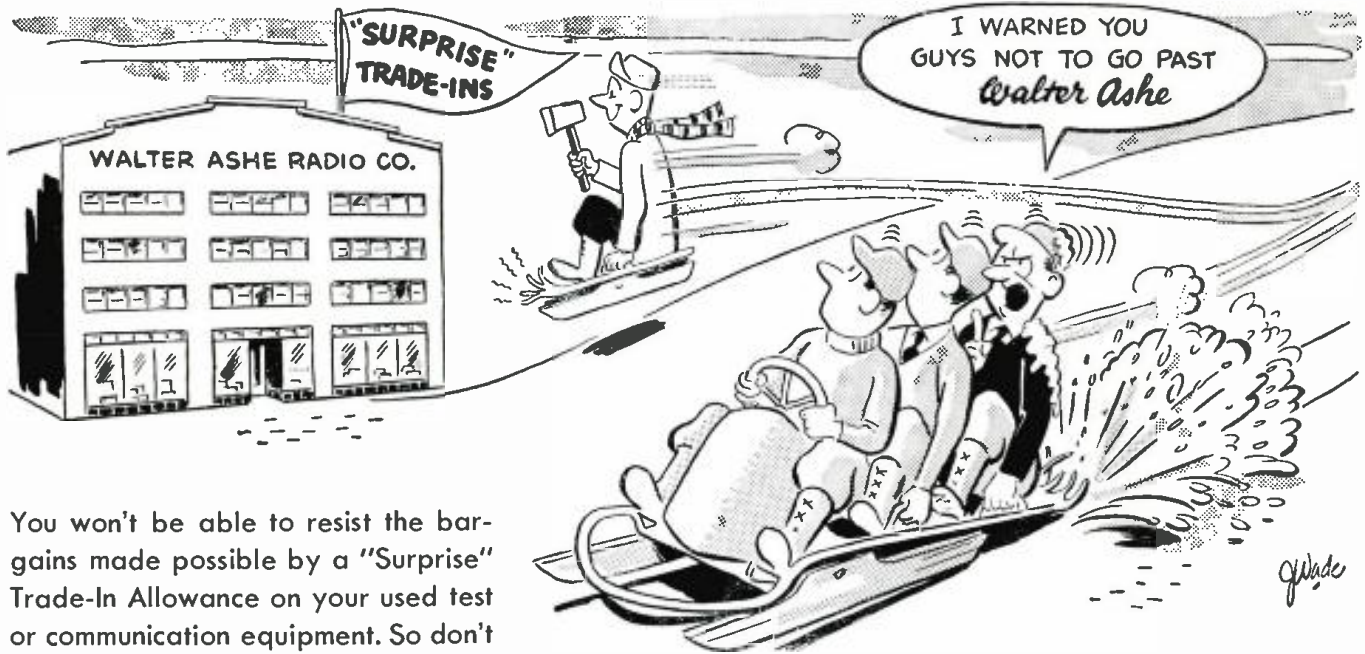

You won't be able to resist the bargains made possible by a "Surprise" Trade-In Allowance on your used test or communication equipment. So don't hesitate. Take advantage now of our better-than-ever "Surprise" Trade-In deal. Trade used, factory-built equipment today. Wire, write, phone or use the handy coupon.



NEW ELMAC AF-67 TRANS-CITER
Net \$177.00



NATIONAL NC-183D.
Less speaker. Net \$383.50



NATIONAL HRO-60.
Less speaker. Net \$533.50



HALLCRAFTERS SX-71.
Less speaker. Net \$249.95



JOHNSON VIKING II
TRANSMITTER KIT. Net \$279.50
Wired and Tested. Net \$337.00



COLLINS 75A-3
with 3 KC mechanical filter.
Less speaker. Net \$530.00

All prices f.o.b. St. Louis
Phone CHestnut 1125

Walter Ashe
RADIO CO.
1125 PINE ST. • ST. LOUIS 1, MO.

FREE CATALOG!

RN-54-1

WALTER ASHE RADIO COMPANY
1125 Pine Street, St. Louis 1, Missouri

Rush "Surprise" Trade-In Offer on my _____
for _____
(show make and model number of new equipment desired)

Send new FREE 1954 Catalog.

Name _____
Address _____
City _____ Zone _____ State _____

Send for your copy today

between the enclosure and the room due to the reinforcement of these two plane surfaces. When the enclosure is placed in a corner, this reinforcement occurs with three plane surfaces, and an appreciable power gain is thus realized in the low frequency range.

Construction

The construction of the enclosure is reasonably obvious from the drawings of Fig. 5. The side walls have been dadoed out to provide a keyed-in sturdy construction which can resist the onslaughts of the heaviest vibrations and pressures built up within the cabinet. These pressures are quite considerable, as may be experienced by turning up the music and standing immediately in front of the cabinet. The pressure waves will actually be felt. The construction with the panels running from side to side is reminiscent of that of an I-beam and certainly exhibits the same structural strength. The front chamber is finished with a hard, non-absorbent substance to prevent any loss in high frequency response. It is also important to place the 1-in. absorbent pads in exactly the location shown in the drawing. Mechanical vibrations of the cabinet are not heard at any frequency.

The entire assembly is glued, nailed, and screwed together as required with the back being removable for the insertion of the speaker. The speaker chamber has been designed to accommodate all of the well-known types available. Speakers smaller than 15 in. are mounted by means of an adapter plate which fits over the normal 15 in. speaker opening. Since the sizes of many of the parts are quite critical, the production enclosures are all cut with the use of special jigs to obtain absolute uniformity of performance. The parts fit together like a jigsaw puzzle due to the dadoed construction, and are quite readily assembled.

A partial list of speakers suitable for use with this enclosure is given in Fig. 5 to aid those who wish to build this enclosure. The performances of these speakers in this enclosure are closely allied with the quality of the speaker selected.

221 STATIONS ON NET

THREE more TV stations have been added to the Bell System's nation-wide television network to bring the total to 221 stations in 137 cities in the United States.

The most recent additions include WCIA-TV in Champaign, Ill.; KCTV, Des Moines, Ia.; and WIBW-TV, Topeka, Kansas.

WCIA-TV receives network programs over inter-city facilities from Chicago while KCTV is fed from the transcontinental radio-relay route and WIBW-TV from the Kansas City-Oklahoma City radio-relay route.

A. T. & T. also announced plans to add two television channels—one in each direction—to the Albany-Buffalo radio-relay route. Application is now pending before the FCC for permission to start this construction.

OUTSTANDING for HIGH FIDELITY!

COLLINS TUNERS and RECEIVERS

BUY DIRECT AND SAVE

'PRE-FAB' AUDIO PRODUCTS CO.

Two ALL NEW Complete Kits for Every High-Fidelity Need

Collins Audio Products Co. is an authorized distributor with Collins Radio Co.

Each Collins Tuner Kit is complete with punched chassis, tubes, power transformer, power supply components, hardware, dial assembly, tuning eye, knobs, wire, etc., as well as the completed sub-assemblies: FM tuning units, AM tuning units, IF amplifiers, etc., where applicable. All sub-assemblies wired, tested and aligned at the factory make Collins Pre-Fab Kits easy to assemble even without technical knowledge. The end result is a fine, high quality, high fidelity instrument at often less than half the cost—because you helped make it and bought it direct from the factory.

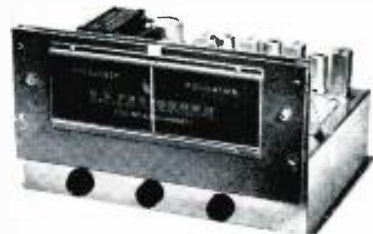

FM Tuner Kit

\$55

The FM-11 tuner is available in kit form with the IF Amplifier mounted in the chassis, wired and tested by us. You mount the completed RF Tuning Unit and power supply, then after some simple wiring, it's all set to operate. 11 tubes: 6J6 RF amp, 6AG5 converter, 6C4 oscillator, 6BA6 1st IF, (2) 6AU6 2nd and 3rd IF, (2) 6AU6 limiters, 6AL5 discriminator, 6AL7-GT double tuning eye, 5Y3-GT rectifier. Sensitivity 6 to 10 microvolts, less than 1/2 of 1% distortion, 20 to 20,000 cycle response with 2DB variation. Chassis dimensions: 12 1/2" wide, 8" deep, 7" high. Illustrated manual supplied. Shipping weight 14 lbs.

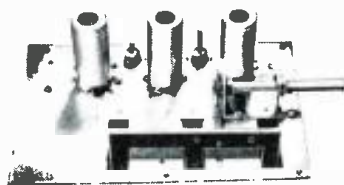

FMF-3 Tuning Unit

\$15²⁵

The best for FM. The most sensitive and most selective type of "front end" on the market. 6 to 10 microvolts sensitivity. Image ratio 500 to 1. 6J6 tuned RF stage, 6AG5 converter, 6C4 oscillator. Permeability tuned, stable and drift-free. Chassis plate measures 6 1/2" x 4 1/2". In combination with the IF-6 amplifier, the highest order of sensitivity on FM can be attained. Tubes included as well as schematic and instructions. Draws 30 ma. Shipping weight FMF-3: 2 1/2 lbs. Dial available @ \$3.85.



IF-6 Amplifier

\$19⁷⁵

A remarkable value! 6 tubes are used in the IF amplifier: 6BA6 1st IF, (2) 6AU6 2nd and 3rd IF's, (2) 6AU6 limiters and 6AL5 discriminator. High gain, wide-band response (200 KC) for highest fidelity. 20 to 20,000 cycles. Distortion less than 1/2 of 1%. Draws 40 ma @ 220 volts. Chassis plate dimensions: 11 1/8" x 2 1/2". Shipping weight: 3 lbs.



AM-4 Tuning Unit

\$24⁵⁰

Tops in AM superhet performance! A 3-gang tuning condenser gives 3 tuned stages with high sensitivity and selectivity. Assembly is completely wired, tested and aligned ready for immediate use. Frequency coverage 540 KC to 1650 KC at a sensitivity of 5 microvolts. Tubes 6BA6 RF amplifier; 6BE6 converter; 6BA6 IF amplifier and 6AT6 detector. Draws 30 ma @ 220 volts. Mounts on a chassis plate measuring 4" x 7 3/8". Shipping weight 2 1/2 lbs. Dial available at \$3.85.



FM/AM Tuner Kit

\$77⁵⁰

The original 15 tube deluxe FM/AM pre-fab kit redesigned on a smaller chassis. The tuner now measures 14" wide by 12" deep by 7 1/2" high. This attractive new front and dial assembly opens up new applications where space is at a premium. Kit includes everything necessary to put it into operation—punched chassis, tubes, wired and aligned components, power supply, hardware, etc. Kit comprises FMF-3 tuning unit, IF-6 amplifier, AM-4 AM tuning unit, magic eye assembly and complete instructions. All tubes included. Shipping weight 19 lbs.



To: Collins Audio Products Co. Inc. RN-1
P.O. Box 368, Westfield, N. J.
Tel. Westfield 2-4390

FM Tuner Kit FM/AM Tuner Kit Slide Rule Dial Assembly
 FMF-3 Tuning Unit IF-6 Amplifier AM-4 Tuning Unit

NAME _____
ADDRESS _____
CITY _____ STATE _____
Amount for Kit \$ _____ See weights, add shipping cost \$ _____
Total amount enclosed \$ _____ Check Money Order

WHEN YOU THINK OF TUNERS, THINK OF COLLINS AUDIO PRODUCTS

Let MILTON S. KIVER Help You Prepare For U.H.F.-TV And...

TELEVISION SERVICING

Easy to TRAIN AT HOME This Practical Way!

Men with the right training in Television Servicing are in big demand... pull down big pay. T.C.I. TRAINS YOU RIGHT with easy-to-follow technical training designed by servicemen, for servicemen! You learn practical, professional type Television Servicing without leaving your present job. Included are money-making extras such as set conversion, master antenna installation, U.H.F.-TV and field servicing short cuts. You can start earning Television money after the first few lessons. You learn to test, trouble shoot and repair all types of TV sets the proven, practical way!

HERE'S HOW YOU GET EXPERIENCE!

You train on your own large screen modern television receiver, furnished as part of your course. This set is yours to keep! As an optional feature you can get two weeks of actual field experience out on service jobs and on the repair bench for Chicago's largest independent servicing organization. You learn Television Servicing by actually doing Television Servicing... you get the practical know-how you need to qualify for BIG MONEY in this fast-growing field! Age is no barrier. Many TCI students are over 40!

VETERANS!
T.C.I. is approved for G.I. training under Public Law 570. Check out both.

ACT NOW! Mail coupon for FREE Catalog and SAMPLE LESSON. Write TODAY!

TELEVISION COMMUNICATIONS INSTITUTE
205 W. Wacker Dr., Dept. AW Chicago 6, Ill.

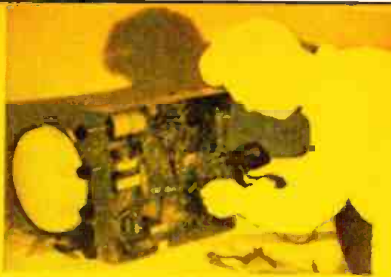

YOU GET and keep modern large screen Television receiver.

YOU DO actual testing, servicing, trouble shooting and repairing

BEGINNERS! LEARN ABOUT NEW BASIC TV COURSE!

You don't need radio experience for practical, home-study training in Basic Television. Start earning money in TV after first few easy lessons. Check coupon for details.

MAIL NOW FOR FREE BOOKLET

MILTON S. KIVER, President
TELEVISION COMMUNICATIONS INSTITUTE
205 W. Wacker Dr., Dept. AW, Chicago 6, Ill.

Rush full facts on practical TV training. I am not obligated. Salesman will not call.

Name Veterans: check here
Address
City Zone State
 BEGINNERS check here for information on Basic Television Course.

Mac's Service Shop
(Continued from page 76)

"Now look, let's not try to win an Oscar with this safety talk," Barney said with a grin. "You're waxing pretty dramatic, you know. I suppose we ought to mention, too, that you should use an insulated rod instead of your fingers for probing around the wiring of a live set."

"That's right," Mac agreed. "On the whole, though, I imagine that a service technician would be likely to be more aware of the danger of electrical shock than he would of other possible sources of injury. For example, we know how important it is to avoid breathing the fumes of carbon tetrachloride or of getting the stuff into your eyes or a break in the skin; yet I still see a lot of fellows handling the solvent as carelessly as though it were water. They ought to read some of the articles that have appeared in radio magazines telling how familiar carbon tet can cause serious illness or even death if mishandled."

"In the same way the average technician has been pretty well impressed with the fact that he should handle a TV picture tube with extreme caution to avoid an explosion, but he does not hesitate to grab hold of a receiving tube with his bare hand and yank with all his might in an attempt to pull it from a stubborn loctal socket. If one of these tubes breaks and cuts a quarter-inch-deep gash in his thumb, as it did in mine, he will not need to be reminded after that to use a tube-puller, leather glove, or some other means of protection when taking out ordinary receiving tubes."

"Even if the tube does not break, you can often get a nasty burn from trying to handle a too-hot tube," Barney remarked.

"Right again," Mac applauded. "and a burn is always dangerous because it affords a good place for infection to start. This is one reason we should all be careful not to be burned with a hot soldering iron or hot solder. Parts being soldered should always be held in place with pliers instead of the fingers. Even though the part can be gripped in such a manner that heat from the joint cannot be conducted to the fingers, there is always the danger that the point of the iron will slip off the joint and dab against them or that a blob of excess solder will roll from the joint or the iron on to the fingers and burn a blister before you can say 'ouch!'"

"What really chills me, though," Mac continued, "is the sight of a guy pulling on a wire with all his might while he softens the solder joint with a hot iron. When the wire finally does break loose, it invariably throws a spray of melted solder, usually directly toward the person pulling on it. A particle of hot solder striking the eyeball could easily cause permanent blindness. Never, NEVER do that. Use

THE BEST BUY IN AUDIO

the new H. H. Scott "99"
INCLUDES EQUALIZER — PREAMPLIFIER,
10-WATT AMPLIFIER, AND POWER SUPPLY.
\$99.95
net



THE TYPE 99-A TRANSCRIPTION AMPLIFIER

An H. H. Scott professional equalizer-preamplifier, 10-watt amplifier, and power supply — all complete in only 13 1/4 x 5 3/4 x 9 3/4 inches. Separate turnover and roll-off controls give 9 equalization curves. Continuously variable bass and treble cut and boost. Automatic loudness control with continuously adjustable compensation. Input selector for phono, tuner, tape, and TV. Inputs for magnetic, crystal, and constant-amplitude pickups and for Dynaflex noise suppressor and dubbing records on tape. Level control for different pickups. Rumble filter with sharp cutoff below 20 cps prevents subaudible overload. Output tubes automatically balanced; speaker outputs 4, 8, 16, and 500 ohms. Write for free booklet No. RN-11. At only \$99.95, it's your best buy in audio!

A COMPLETE AMPLIFIER

99

HERSON
HOSMER

SCOTT, INC.

"PACKAGED ENGINEERING"

385 PUTNAM AVE. • CAMBRIDGE 39, MASS.

99

AT NEW LOW PRICES BROADCAST BAND and AERO



Ideal for Use in Boats, etc.

MN-26-C Remote Controlled Navigational Direction finder and communications receiver. Manual DF in any one of three freq. bands, 150 to 1500 KC. 24 V. Self contained dynamotor supply. Complete installation, including receiver, central box, loop, azimuth line and flex. shafts.

ALL UNITS BRAND NEW EXCEPT CONTROL BOX

MN-26-Y 150 to 325 KC, 325 to 695 KC, 3.4 to 7 megacycles, comp. installation.....\$69.50
 MN-26-C alone, like new.....21.95
 MN-26-Y as is less tubes.....4.95
 MN-20-E Loop, Brand New.....6.95
 MN-52 crank drive, New.....2.50
 MN-26LB Receiver exc.....59.50

Low Freq. Crystals—FT 241 A for 55B, lattice filter, 1/2" spc. 54th harm channels listed by fund. Fractions omitted.

370	388	407	425	444	462	481	501
372	390	409	427	446	464	483	503
374	392	411	429	448	466	485	505
375	394	412	431	450	468	487	507
377	396	414	433	451	470	488	509
379	398	416	435	453	472	490	511
381	400	418	437	455	474	492	512
383	401	420	438	457	475	494	514
385	403	422	440	459	477	496	516
387	405	424	442	461	479	498	

Radar Indicator unit for conversion to test scope or for use as a modulation monitor. Complete with tubes. But, less 5BP1. Parts alone are worth much more. FREE 5BP1 (while they last) with above. New \$9.95

954, 955, CK1005, 1625, 1626, 1619, 33, 34, 9002, 9004, 9006, 6Z7G, 6J5, 12A6, 1F4G, 1F5G

10 Assorted for \$3.00

DYNAMOTORS: The best dynamotor for conversion to 6v. Multiple winding. After conversion you get choice of 190 or 350 v. at 50 MA or 250 v. at 100 MA. Complete dope sheet furnished. BRAND NEW (See "CQ" Aug. issue).... \$4.65

BC 223 Tuning Units\$2.49 ea.

RL-42 REVERSIBLE MOTOR WITH ANTENNA REEL AND CLUTCH, USED. \$1.95
 3 for \$5.00

SURPRISE PACKAGE

20 lbs. of assorted good radio parts. A real value at \$1.95

MISCELLANEOUS EQUIPMENT

FL-8 used, exc.\$1.19
 BC-347 each95c
 3 for \$2.00

ID6/APN4

Made to operate in conjunction with Radio Receiver R-94/APN-4. Unit includes 19 tubes, one 5" scope tube, crystal controlled standard oscillator, sweep circuits, marker pulses. Excellent cond. \$42.50

Also available: 1D6A, 1D6B. Write for quotations.

Hundreds of items in stock. WRITE FOR NEW BULLETIN AND PRICES. Shipments F.O.B. warehouse. 20% Deposit on orders. Minimum order \$5.00. Illinois residents, add regular sales tax remittance. Prices subject to change without notice.

MONTHLY SPECIAL

All Four Items For \$10.00

RT7/APN-1 TRANSCEIVER UNIT—Used as an altimeter, it may be converted for signaling control circuits, etc. Used, less tubes, as is \$4.95

RT/34 APS 13 TRANSCEIVER used as a tail warning radar on 415 MC. Containing a 30MC IF Strip and various other parts, these units have been stripped of RF sections and all tubes, but are an excellent buy in only for parts and IF Strip. Used..... \$4.95

BC 906 FREQUENCY METER—Range 150-225 Mc with modification possible for lower frequencies of TV, etc. Contains 0-500 DC microammeter and uses Battery pack of 1.5 V and 45 VDC..... \$4.95

R-1/ARR-1 220 Mc converted with minor alterations becomes a high gain converter with two stages of RF amplification—(complete with diagram). New..... \$4.95

BC-929 3" RADAR SCOPE—brand New \$19.95

BEAM ANTENNA SELSYN TRANS. MITTER and indicator, per set..... \$12.00

BC-684 FM Transmitter, 27-38 mc, used, exc.\$14.95

BC-604 FM Transmitter, 20-27 mc, used, exc.\$11.95

RA 10 FA Receiver, new\$17.95

RA 10 DB Receiver, new\$24.95

RA-52 RECTIFIER

Transtat controlled to produce high voltage DC from 110 VAC 60 cycle source. Up to 11,500 VDC @ 50 W. Metered high voltage (0-15 KV) and current (0-20 MA). \$69.95
 Exc.

Collins Auto Tune—Assembly for ARC-1, brand new \$69.50

BC-624 receiver (SCR 522), less tubes, 100-156MCused \$14.95

	As Is	Less	Exc.	New
	Tubes	Used	Used	
BC-455 Receiver, 6 to 9 mc.....	—	—	\$9.95	—
BC-456 Modulator.....	\$2.95	4.95	—	\$7.95
BC-458 Transmitter, 5.3 to 7 mc 2.95	—	—	—	—
BC-459 Transmitter, 7 to 9 mc 2.95	—	—	—	—

Control Boxes, racks, receivers for above in stock—write.

BC-1033 62-80 mc recr. Like new, less tubes ea. \$5.95
 BC-1023 brand new with tubes.....9.95
 BC-709 Inter. Ant. New.....3.95

SCR-625—FAMOUS ARMY MINE-DETECTOR For Prospectors, Miners, Oil Companies, Plumbers, etc. This unit is being offered now at a considerable reduction in price. Recently advertised at \$79.50 it is now available in the same brand new wrappings in suitcase style carrying case (less batteries). New\$59.50

SCR-522—Transceiver, complete in case with top bracket, less tubes\$29.95

RU-19—Receiver. Complete control box and coils—brand new\$17.95

TRANSCEIVER

140-144 mc, 2 meter, used, excellent condition, less dynamotor, less tubes, Only\$10.95
 with tubes \$19.95

WOBLATOR

BUILD TV-FM-AM SWEEP GENERATOR

You can build "Versatile Sweep Frequency Generator with APN-1 magnetic units." \$ 5.95
 R-1206 Beacon Receiver . . . 200-400KC. 9.95
 TS-147/AP Test Set..... 39.50
 Tuning Units TS16, TN17, TN18.....each 200.00
 IE 10A-SCR522 Test Unit..... 295.00
 I-222-Signal Generator—Used, exc. 95.00

MG-149F excellent condition.....\$ 89.50
 MG-149H excellent condition..... 129.50
 MG-153 Inverter.....Used 24.95

P-206, inverter, like new.....\$12.95
 PE-218, inverter, excellent condition..... 24.95

BC-640\$695.00
 BC-639 with RA 42 rectifier..... 225.00

5" Bakelite Speaker case such as used on Intercoms \$5.99 each (less speaker); 4 for.....\$2.00

IMPACT SWITCHES Brand new 59c
 10 for \$5.00
BK-22 Relay Unit & terminal box for ADF—Used \$2.95
2 Volt Vibrators 10 for\$3.00 ea. 39c

LOOK WHAT YOU GET FOR \$14.95

- 350 feet of continuous length of 50 ohm coaxial cable
- 100 feet of same coaxial cable
- Cavity type attenuator
- 6 Short lengths of RGSU with connectors and sockets
- In wooden cases—shipping weight 30 lbs.—all for\$14.95
- TS41 Hand Sets, excellent condition..... 5.95
- TS Type, exc., less cord..... 2.95
- EE8 Portable Telephone exc. cond. ea. 18.95
- 10 assorted electrolytics..... .95
- 100 asstd. 1/2 and 1 W carbon resistors..... .95
- 2,2,2 mid @ 4000 Volts..... 1.49

MIKES and HEADSETS

T-26 Telephone chest unit with F-1 Western Electric Transmitter\$2.39
 HS-33 Low Impedance Head-set.....exc. \$2.95 new \$5.45
 HS-23 Headset used 1.89 new 4.50
 CD-307 Ext. cord for HS-23-33.....like new .79 new 1.29
 Throat Mike—T-30.....new .98
 Lip Mike—Navy Type.....new .98
 CW-49505 High Impedance headset complete with headband.....Used 98c
 T-45 Lip Mike, New.....\$1.75
 HS-30, miniature headset. Used \$1.49; new 2.49



MARK II TRANSMITTER & RECEIVER

Ideal for mobile or stationary use. 15 Tube Set transmits and receives 2 to 8 MC. Phone, CW and MCW 25 Watt Master Oscillator Control. Transmits and receives 240 MC. Phone. Also an intercommunicating set. Comes complete with 15 Tubes, Headset, Alarms, Antennas, Control Box, 12 24 Volt Power Supply, and instructions—ready to operate. Set size: 27"x10"x13 1/2". Price\$59.50
 Available—All Parts and Accessories for Mark II Sets!

WANTED:

All TS, APR, APS, ARC, ARN, SCR, R89 and BC equipment . . . write today!
 Quote lowest prices in your first letter

R. F. MODULATOR

Complete tunable 205 mc Test Set. With 110 V., 60 cps, power supply, 3-stage audio amplifier, terrific chassis for experimentation, good condition\$8.95

TU 8, 9 or 10—Tuning Unit for BC 375—used, good cond.\$1.95

11 TUBE UHF TUNABLE RECEIVER 234-528 mc, less tubes\$7.95

BC433 RADIO COMPASS RECEIVER, 200 to 1700 KC, used, excellent condition less tubes\$19.95
 used, as is, less tubes and cover, excellent for parts only.....5.95

DYNAMOTORS

TIME INTERVAL UNIT—Consists of line delay, vibrating element, and diaphragm mounted in box approx. 9 1/2" x 6 1/2" x 9 1/4". Weights approx. 10 lb. Surplus Property. Easily used for burglar alarms, fire alarms, fog horns, etc. ea \$6.79

DM-28—Dynamotor for BC-318—28V DC at 1.25 amps in 220 V at 70 MA output Good \$4.95

DM-32A—Dynamotor for Command Receiver 28V at 1.1 input 250V at 60 MA outputUsed 2.95 New 7.50

DM-33—Dynamotor for Command Transmitters—Used \$2.95

D-101 Imp. 27V 1.75 Amp. output 285 VC .075 ampeach \$1.95 3 for \$5.00

PE103—6V Dynamotor.....Used \$22.95
 I.D. 70—S Meter.....New 89c

BUY NOW!

R W ELECTRONICS

Dept. N, 2430 S. Michigan Ave., Chicago 16, Ill.

PHONE: Calumet 5-1281-2-3

BUY NOW!

Reliance Specials

COAXIAL CABLE CONNECTORS

Full line of JAN approved coaxial connectors in stock.



RG-1AC	50.42	PL-274	\$1.10	UG-88 U	50.90
RG-1AC	35	PL-275	2.40	UG-89 U	1.10
RG-1F	1.10	UG-137 U	1.70	UG-103 U	.68
RG-1H	1.20	UG-148 U	1.00	UG-101 U	1.40
RG-1HP	.22	UG-208 U	1.85	UG-103 U	1.50
RG-1J	.73	UG-214 U	.85	UG-106 U	.15
RG-1K	.40	UG-218 U	1.00	UG-107H U	2.75
RG-1RTV	.65	UG-218 U	1.05	UG-110 U	2.00
RG-1SP	.45	UG-210 U	1.45	UG-107 U	3.75
RG-1SPN	.50	UG-224 U	1.30	UG-173 U	.12
RG-1T	1.30	UG-224 U	1.60	UG-176 U	.12
RG-2AP	1.95	UG-220 U	1.20	UG-185 U	.95
RG-2B	2.10	UG-21 U	1.20	UG-196 U	1.65
RG-2B	1.60	UG-218 U	1.50	UG-204 U	1.15
RG-22AP	1.40	UG-230 U	1.10	UG-224 U	1.15
RG-22P	2.10	UG-21 U	1.30	UG-253 U	1.95
RG-22P	1.45	UG-270 U	1.25	UG-264 U	1.95
RG-22R	.68	UG-274 U	2.25	UG-261 U	1.10
RG-22SP	.80	UG-278 U	2.95	UG-262 U	1.10
RG-22T	1.65	UG-278 U	1.25	UG-274 U	1.15
RG-108	.12	UG-208 U	1.75	UG-374 U	2.30
RG-185	1.12	UG-10 U	2.30	UG-390 U	.90
CW-123A/U	.15	UG-218 U	1.85	UG-384 U	1.95
M-358	1.30	UG-288 U	.70	UG-408 U	2.65
M-350	.30	UG-284 U	.90	UG-414 U	1.95
M-359A	.35	UG-274 U	1.75	UG-408 U	1.95
PL-258	.75	UG-83 U	1.75	UG-625 U	1.35
PL-259	.45	UG-83 U	1.65	Quotations on	
PL-259A	.50	UG-87 U	1.40	All Other Types	

NEW COAXIAL CABLES JAN APPROVED

RG 8 U	Price Per Ft.	RG 58 U	Price Per Ft.
RG 11 U	12 1/2c	RG 39 U	7 1/2c
RG 22 U	19c	RG 62 U	9c

Reduct 20% 500 ft. or more of a type.

RG-8 U Brand New Govt. Surplus 100 ft. coil, \$5.95

SOUND POWER PHONES

Sound Powered Handset
T-5-10 TYPE

Uses no batteries or external power source. Ideal for TV installation work, farms, construction projects, connecting telephones, faxes, extensions, etc., includes 5 ft. cord. Each. **\$9.48**

SOUND POWERED HEAD & CHEST SET

Navy type M head and chest set, brand new. For work requiring free use of hands. Heavy duty—consists of headset with 2 phones and chest microphone. Includes 20 ft. rubber cord. Each. **\$14.88**

32 MFD 2500 VDC Photoflash Capacitor	\$15.80
1N34 Crystal	56c
2N2 Tubes RCA	2 for 1.00
6X27 Tubes Sylvania or Kenrad	3 for 2.20
1 meg 1W 1% Precision Resistor WW	2.50
Gear Asst. 100 gears, bushings, etc.	6.50
Hardware Assort. 3 lbs. nuts, bolts, etc.	2.00
200 assorted resistors, 1/2W all insulated	2.50
10 MA DC Meter 3" Rd. Dial	3.95
1 MA DC Meter 3" Rd. Dial	2.10
1 MA DC Meter Fan type	2.50
5 amp AC Meter 4" Rd. Dial	4.11
500 MA DC Meter 2 1/2" Rd. Dial	2.95
30 VDC Meter 2 1/2" Rd. Dial	1.95
500 micro amp DC Meter 2 1/2" Rd. Dial	4.30
SPST toggle switch RAT handle 3A 250V	27c
SPDT toggle switch RAT handle 3A 250V	31c
DPDT toggle switch RAT handle 3A 250V	55c
4PDT toggle switch RAT handle 10A 125V	1.95
Universal Joint Aluminum 3/4" hole 1 1/4" long	85c
Universal Joint Aluminum 3/16" hole 1 1/4" long	80c
1 RPM Timing Motor Havlan 1 1/2 VAC	1.95
8 RPM Timing Motor Ingraham 1 1/2 VAC	1.75

A LOT OF "BUDS" TO DO A LOT OF WORK

HIGH CURRENT Filament Transformer, Pri. 105-125 Vac 60 cy 1 Phase Sec. 5V @ 190 Amps. 97KVA. Insulated for 35 KV RMS. Just the thing to light up 100w 34 1/2" tubes. Ideal for welding, thawing frozen pipes, etc. WT. 80 lbs. **\$29.50**

SELSYN MOTORS

Army Ordnance Type C-78248 115V, 60 Cy. Transmitter. Approx. 3 3/4" dia. x 5 3/8" H. Like new. **EACH \$7.50**

50 V. 50 Cy. High Torque. Connect in Series For Use On 110 V. 60 Cy. Approx. 1 1/2" dia. x 3 1/2" H. Like new. **ONLY \$12.95 PAIR**

FILTER CHOKE—10 HY

400 MA. 90 OHMS **\$4.88**

3500 VDC. Test HERMETIC SEALED

Size: 4 1/4 x 4 1/2 x 4 1/4 H.

STORAGE BATTERIES—SHIPPED DRY

BB24 Willard ni-cad case. Built in charger indicator 2V 20 amp. hrs. EA. \$2.95

BB212 U—2V 40 amp. hrs.—07482288 1 1/2" dia. EA. \$2.35

NT-6—6V 3.5 amp. hrs.—314x1 1/2 x 2 3/8" dia. EA. \$1.95

OIL FILLED CONDENSERS

MFD	VDC	PRICE	MFD	VDC	PRICE
2	400	50.55	3	2000	53.75
6	400	.85	8	2000	7.95
10	600	.95	12	2000	8.55
20	600	.69	2	4000	7.95
30	600	.95	1	8000	4.88
4-4-4	600	1.95	1	10000	6.50
5	600	2.50	02-02	7000	1.55
8	600	1.75	1	7000	1.79
10	600	1.85	1	8000	6.50
50	600	7.95	075-075	8000	6.50
1	1000	.69	25	10KV	29.50
2	1000	1.95	1	15KV	45.00
4	1000	1.59	1	16KV	8.95
2	2000	1.59	001	20KV	19.95
4	2000	1.30	2	50KV	24.50
1	2000	1.95	2	50KV	42.50
			2	50KV	85.00
			1	50KV	95.00

TERMS—Cash with Order or 25% Deposit—Balance C.O.D. Net 30 Days to Rated Accounts. All Prices are Net F.O.B. our Warehouse. Send for our Latest Bargain Catalog.

RELIANCE MERCHANDISING CO.

2221 ARCH ST., PHILA. 3, PA.

a soldering tool to free the end of the wire and work it loose while the iron keeps the joint hot; but never pull on the wire while you are doing this so that it becomes a slingshot for throwing molten solder into your face."

"You keep on," Barney warned, "and you're going to convince me that a radio or TV chassis is nothing but a booby-trap. I'll be afraid to touch one of the things."

"You'll be safe enough unless you really are a booby," Mac said with a grin. "I'm not saying, however, that even a careful person can always avoid a minor scratch or burn; but such a person will take care of the minor injury promptly and so insure that it remains just that. Whenever you break the skin, even with the smallest scratch, I want you to go to the first-aid cabinet at once and apply an antiseptic. The quicker you do this the less likelihood will there be that germs

can enter the bloodstream through the cut. Burns should be treated just as promptly. Remember, too, that the baking soda in the cabinet is for neutralizing battery acid that may happen to splash on the skin.

"Finally, you know how strongly I feel about every technician being an expert at administering artificial respiration. Probably this is the best weapon we have against unnecessary death from electrical shock, and I think it is near-criminal for anyone who works with electricity to be ignorant of this life-saving process. To work with electricity and not be able to administer artificial respiration is like a professional snake hunter plying his trade without a vial of snakebite serum in his pocket."

"That would definitely be un-good," Barney agreed. "Perhaps I'd better do a little brushing up on my first aid techniques!"

CANADIAN EXHIBITION

AFTER reading the article "Electronics Goes to the Fair" in the September issue of RADIO & TELEVISION NEWS, Ron Moyer, VE3SWL, of Kitchener, Ontario sent us details on the elaborate sound system installed at the Canadian National Exhibition which is held annually in Toronto.

The Exhibition has been held for the last 75 years with the exception of the World War years. It was incorporated in 1879 and has approximately 30 permanent buildings installed on the grounds. The value of the land, buildings, and plant equipment is nearly 50 million dollars. The annual cost of staging the exhibition, exclusive of exhibitors' interests, is 2 1/4 million dollars.

The total area occupied by the exhibition is 350 acres and over 2 1/4 million square feet of display space are provided for exhibitors.

A. G. Godfrey of the Works Department, Sound System of the Canadian National Exhibition advises that all of the equipment used is the property of the exhibition and, with the exception of several major installations, is taken down each year and stored.

The major installations are located at the grandstand, bandshell, coliseum, and the grandstand central control. The grounds system consists of remotely-controlled amplifiers located at the Automotive Building, Prince's Gate, the grandstand marquee, the Manufacturers' Building and the Government Building. These amplifiers are controlled from the central control studio in the grandstand mezzanine.

The loudspeakers used in the ground system are, for the most part, Altec Lansing multi-cellular, high-intensity horns with dual Western Electric #720 driver units. Several of the locations, such as the grandstand marquee and the Manufacturers' Building, are also equipped with 15-inch Altec #304 bass speakers. The waterfront system is fed from the bandshell and is covered by twenty 24-inch re-entrant trumpets with 50-watt drivers. These horns are mostly Atlas units but Jensen and University speakers are also used.

The bandshell is equipped with two Altec 15-inch #304 bass speakers in reflex baffles plus four Altec 2X6 multi-cellular tweeters driven by Altec #288

driver assemblies. The amplifier in the bandshell also drives the waterfront system. The grandstand utilizes four Altec #304's plus four Altec wide-angle, high-intensity multi-cellulars equipped with eight #288 drivers. The bass baffles, specially built, are seven feet high and four feet wide and have a volume of 112 cubic feet. They are mounted on thirty-foot towers on each side of the stage.

All of the amplifiers used are standard Northern Electric #118 power amplifiers, #117 mixer-driver amplifiers, and #116 preamplifier series. The grandstand, coliseum, and bandshell are equipped to handle 400, 300, and 200 watts respectively. The coliseum system, located in the arena, feeds the Horse Palace, the coliseum arena, the hitching ring, and the Cow Palace, either separately or simultaneously. The grandstand central control studio handles and controls the waterfront program, all radio broadcasts and pickups throughout the park, and television audio lines to the various studios. It is equipped with driver amplifiers to feed all the remote amplifiers in the park. It is from here that the v.h.f. equipment is located for communicating with TCA flights.

The microphones are all 50-ohm impedance units. Western Electric #633A and #639 microphones are used for general purpose pickup. Microphones employed for the show are Altec #21B pencil microphones which are sensitive and give excellent reproduction. In addition, they also use a few Shure #656 microphones plus RCA "Junior" velocities and assorted lapel mikes.

Two Ampex #401 tape recorders are used in the grandstand. In addition several smaller machines, such as Webeor, are used in other locations including the Coronation Coach exhibit this past year.

Since all of the systems can be tied together in case of emergency no mobile equipment is used at the exhibition.

During the exhibition, there are 32 separate sound systems in operation utilizing over 75 microphones and approximately 150 loudspeakers. To handle the job, the exhibition employs eight technicians to maintain and install this equipment and twenty operators.

Our thanks to Mr. Moyer for sharing this interesting information with our other readers.

Within the Industry
(Continued from page 28)

offered on a custom-engineered basis . . . **KAYE-HALBERT CORP.** of Culver City, California has absorbed all facilities of **PACIFIC INSTRUMENT AND CONTROL COMPANY**, producers of servo-instrumental precision equipment for aircraft and industrial use . . . **THOMPSON PRODUCTS, INC.**, Cleveland manufacturer of aircraft, automotive, and electronic parts, has purchased **BELL SOUND SYSTEMS**, Columbus, Ohio amplifier and tape recorder maker . . . **CAPITOL COMMODITIES, INC.** and **RADIO SURPLUS CORPORATION**, both of Chicago, have been merged and will operate under the **CAPITOL** name at 1229 W. Washington St. . . . **GENERAL COMMUNICATIONS, INC.** has been established as a new factory distributing firm at 1420 E. 25th St., Cleveland 14, Ohio . . . **CBS-COLUMBIA INC.**, the receiver manufacturing subsidiary of **CBS**, has been made a division of **CBS** and will operate as **CBS-COLUMBIA** . . . **LEWIS W. REYNOLDS** has established a representative firm at 2957 Hardman Court, N.E. in Atlanta, Ga. The new organization will bear the founder's name.

* * *

ROBERT A. ELLIOT has been appointed manager of the distributor sales division for *Erie Resistor Corporation* of Erie, Pa.



He has over 20 years' experience in the electronics field and has been associated with *Pioneer Electric and Research Corporation* as sales manager before joining *Erie*. Prior to that he was sales manager of the jobber division of *Standard Coil Products Co., Inc.* and was also associated with *NBC, RCA, and RCA International*.

He assumed his new duties on September 3rd of this year.

* * *

OHMITE MFG. CO. has moved its offices to 3601 Howard St., Skokie, Illinois. Manufacturing will be handled at both the new plant and the firm's old plant in Chicago . . . **THERMADOR ELECTRICAL MANUFACTURING COMPANY** has opened a new electronic division at 2000 S. Camfield Ave., Los Angeles 22, California . . . **PERMULTH-COMAN & ASSOCIATES**, thirty-year-old manufacturers' representative firm in the California-Arizona area, has moved to new and enlarged quarters at 2419 S. Grand Ave., Los Angeles 7, California . . . **JERSEY ELECTRONIC DISTRIBUTING COMPANY** has opened a new electronic "super mart" at 524 21st Ave. in Paterson, N. J. . . . **KALBER & MACK**, sales representatives, has moved to 1 Park Avenue in Manhasset, New York. The firm was formerly located in New York City.



NEWCOMERS OR OLDTIMERS

HOW TO TROUBLESHOOT

A TV RECEIVER

by J. R. Johnson

A step-by-step guide for newcomers to rapid systematic troubleshooting. Read this book and start out on the right foot!

Over 120 (5 1/4 x 8 1/4") pages..... \$1.80

HOW TO USE SIGNAL AND SWEEP GENERATORS

by J. R. Johnson

First book on all types of signal and sweep generators. Gives test uses and discusses problems and their solutions in using this equipment. Applications of all signal and sweep generators in AM, FM radio and TV servicing.

Over 140 (5 1/2 x 8 1/2") pages..... \$2.10



COMPLETE COLOR TV STORY

INTRODUCTION TO COLOR TV

by Thomas & Kaufman

Complete story on NTSC color TV system. Explains how color receiver differs from black and white; how single and triple gun color tubes differ from black and white picture tubes. Answers all questions on present day color TV.

Over 100 (5 1/4 x 8 1/4") pages, illus..... \$2.10

TV TROUBLESHOOTING AND REPAIR GUIDE BOOK VOL. 2

by R. G. Middleton

Companion book to best selling Vol. 1. Finest practical book to make TV servicing easy. Spot TV receiver troubles fast. All items in TV receivers not in Vol. 1 Does not duplicate!

Vol. 2, 160 (8 1/2 x 11") pages..... \$3.30

Vol. 1, 204 (8 1/2 x 11") pages..... \$3.90

GUIDE TO AUDIO REPRODUCTION

by David Fidelinan

A to Z explanation of the reproduction of sound, design, construction, assembly and testing of sound systems and their components. Valuable for service technicians, engineers, amateurs.

Over 250 (5 1/2 x 8 1/2") pages..... \$3.50

OBTAINING AND INTERPRETING TEST SCOPE TRACES

by J. F. Rider

Over 500 actual photographs of test scope traces. Shows how to use scopes and what traces mean. Valuable for servicing TV receivers, FM and AM radio receivers, audio systems and test equipment. Specific test equipment set-ups shown with each application. No other book like it!

Over 140 pages..... Only \$2.40

CAREFULLY SELECTED
for EVERY NEED
of **RADIO, TV**
Service Technicians

POSITIVE CURES FOR TV TROUBLES



TV MANUFACTURERS' RECEIVER TROUBLE CURES

VOL. 1, VOL. 2, VOL. 3 and VOL. 4

Positive cures for TV troubles! Gives you exact directions for correcting TV receiver performance "bugs" Each cure is official, factory-authorized, direct from the receiver's manufacturer. Listings by manufacturer and model or chassis number. Helps correct the most difficult faults—picture jitter, hum, instability, buzz, tearing, etc.

Vol. 1, 115 (5 1/4 x 8 1/4") pages..... \$1.80

Covers 12 brands, Admiral through Dumont.

Vol. 2, 117 (5 1/4 x 8 1/4") pages..... \$1.80

Covers 11 brands, Emerson through Jackson.

Vol. 3, 119 (5 1/4 x 8 1/4") pages..... \$1.80

Covers 16 brands, Kaye-Halbert through Philco.

Vol. 4, Over 115 (5 1/4 x 8 1/4") pages..... \$1.80

Covers 10 brands, Philharmonic through Shaw TV

VOLUME 5 COMING SOON!

Prominent manufacturers not in first 4 volumes. ONE SERVICE JOB WILL MORE THAN PAY THE COST OF THIS SERIES OF BOOKS!

TV SWEEP ALIGNMENT TECHNIQUES

by Art Liebscher, Test Equipment Specialist

Never before has there been a book such as this on TV sweep alignment! An expert gives you accurate time-saving methods and tells you how they work. Introduces the new Supermark method. Chock-full of sweep curve pictures. Valuable for servicing in UHF signal areas.

123 (5 1/2 x 8 1/2") pages, illus..... \$2.10

ENCYCLOPEDIA ON CATHODE-RAY OSCILLOSCOPES AND THEIR USES

by Rider and Usland

Most complete 'scope book! Cloth cover

992 (8 1/2 x 11") pages, 3000 illus..... \$9.00

RECEIVING TUBE SUBSTITUTION GUIDE BOOK

by H. A. Middleton

Answers all tube problems by listing 2,500 radio-television tube substitutions in numerical sequence, with accompanying wiring instructions, original and substitute socket illustrations.

224 (8 1/2 x 11") pages..... \$3.00

FIRST SUPPLEMENT, RECEIVING TUBE SUBSTITUTION GUIDE BOOK

48 (8 1/2 x 11") pages..... \$.99

UHF TELEVISION ANTENNAS AND CONVERTERS

by A. Lytel

Latest information on all types of converters, antennas, transmission lines. Valuable for UHF installation techniques

Over 128 (5 1/4 x 8 1/4") pages..... \$1.80

WRITE FOR COMPLETE RIDER CATALOG

Buy these books now from your jobber, bookstore — if not available from these sources, write to:

JOHN F. RIDER PUBLISHER, INC.
480 Canal Street, New York 13, N. Y.

Export Agent: Roburn Agencies, Inc., 39 Warren Street, New York 7, New York

West Coast Office: 4216-20 W. Jefferson Blvd., Los Angeles, California

Cable Address: Roburnage N. Y.



NEW! 1954 TV CONSULTANT
TV Serviceman's Silent Partner



New, easy-to-use way to solve toughest TV troubles. UHF sect. includes conversions, installations and servicing. Modern alignment methods shown by pictures, diagrams and simple directions, tell exactly what to do and how to do it. Practical pointers on use of all TV Test Instruments. Over 300 pix, raster and sound symptoms. Detailed directions tell where and how to find faulty parts. Over 135 RAPID CHECKS, many using pix tube as trouble locator. 125 illustr. of scope wave forms, diagrams, station patterns, show various defects—take mystery out of TV servicing. **NO THEORY—NO MATH—NO FORMULAS**—just practical service info. covering all types of TV sets. **Only....\$2**

NEW! 1954 TV TUBE LOCATOR
ALL PIX TUBES LISTED!



Money making Time Saver tells which tubes to replace to cure every type of tube trouble. Over 125 such TV troubles listed with clear charts for quickly locating the faulty tubes. Copyrighted TROUBLE INDICATING TUBE LOCATION GUIDES for over 5000 most popular models from Admiral to Zenith plus PIX TUBES used in each model! 1947 to 1954 models. A storehouse of valuable TV servicing info. priced very low for large volume sales. **Only....\$1**

NEW! Trouble Shooting PIX GUIDE
incl. TV TERMS Explained

Sect. 1 is a fully illustrated GUIDE to off-recurring pix faults. Causes and cures explained. Copyrighted Trouble Indicating illustrated chart tells where troubles start in typical TV set — illustrations show resulting faulty TV pictures. Sect. 2 explains hundreds of TV terms in non-technical language. SPEEDS UP TV SERVICING — HELPS YOU DO A BETTER JOB FASTER! **Only....\$1**



NEW! TV TROUBLE TRACER

VOL. 1 & 2 NOW READY! 70 common TV troubles traced to source and cured. Copyrighted trouble indicating tube location guides covering over 1200 most popular TV models. Many models different from those shown in TV TUBE LOCATOR. Each contains over 70 illustrations and tube location guides. Forty most common picture troubles illustrated, with symptoms described, causes given and remedies prescribed. **Vol. 1 only 50c Vol. 2 only 50c**



H. G. CISIN, PUBLISHER

Order from your Jobber today, or if not stocked, write to Harry G. Cisin, Dept. R-1 Amagansett, New York

Enclosed find \$..... Send
 TV Consultant TV Locator
 TV Pix Guide TV Tracer, Vol. 1
 TV Tracer, Vol. 2

Name
 Address
 City Zone... State.....

HEADPHONES for RADIO and TV

By H. S. RENNE

Technical Editor, RADIO & TELEVISION NEWS

Treat yourself to a little "peace and quiet" by installing headphones for your youngsters' radio and TV listening.

HAVE you ever been on the verge of becoming a raving maniac when the kids keep the volume on full blast for their wild west TV shows? or felt like leaving town when Junior was playing his favorite "be-bop" records at a level of roughly 120 db? or wanted to outlaw baseball when Father insists on maximum volume for the Sunday afternoon game? or wished to throttle all concerned when Mother was listening to one of the more sentimental soap operas? A couple of pairs of judiciously spotted headphones can many times alleviate or eliminate these petty annoyances and at the same time provide additional enjoyment for all members of the family.

Connecting a pair of headphones to the radio or TV set is a very simple matter. However, it is usually desirable to silence the speaker at the same time and to provide separate volume controls for each pair of headphones. We will start our discussion with a description of a deluxe arrangement which will provide all of the desired features and will then show how this arrangement can be simplified if such elaborate operation is not desired.

Fig. 1 is a circuit diagram of the deluxe system. A control box (B) is located at a convenient spot near the favorite easy chair or close to the children's choice viewing spot. This control box contains an "on-off" switch, the phono jacks, and the volume controls and is connected to the radio or TV receiver by means of a 3-conductor cable, Fig. 1A. The switch at the control box turns the loudspeaker off when the headphones are turned on. A volume control is provided for each set of headphones.

The transformer at the control box can be a cheap output transformer of just about any kind. It is connected "back-to-back," that is, the voice-coil winding is connected to the voice-coil winding of the radio or TV receiver. Each pair of headphones is then connected across half of the push-pull primary. With normal loudspeaker volume, this connection will provide more than adequate headphone volume. The separate volume controls each consist of a 5000 ohm pot connected across half the output transformer primary.

This type of circuit will supply four sets of headphones if desired. The two extra sets may be connected as shown by the dotted lines in Fig. 1B. Individual volume controls can be pro-

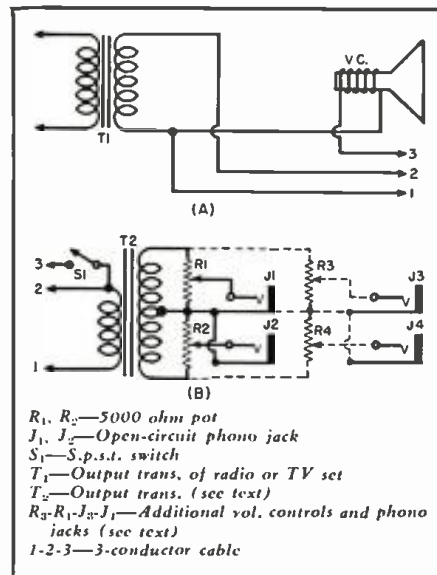

Fig. 1. (A) Method for connecting deluxe control box (B) into radio or TV receiver.

vided for each set as shown, making the unit very versatile.

It should be noted that the 3-conductor cable carries only voice coil currents and so presents no fire or shock hazard. Ordinary intercom cable or practically any type of 3-conductor cable can be used, and runs of 15 feet or more can be installed without appreciably affecting the normal operation of the receiver.

As mentioned before, this is a deluxe system in which the cable may be permanently connected to the set. The switch at the control box controls operation of the device. Some simplification results if a closed-circuit jack is installed at the receiver and a two-conductor cable used, as shown in Fig. 2A. Operation of the receiver is normal until a plug is inserted in the jack. This insertion opens the circuit

Fig. 2. (A) Connecting the simplified circuit (B) into the associated receiver.

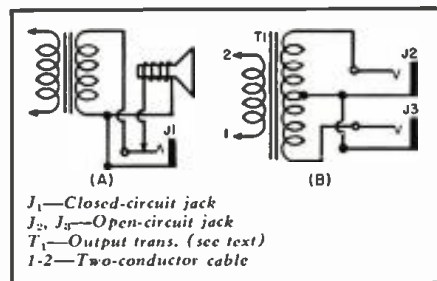

J₁—Closed-circuit jack
 J₂, J₃—Open-circuit jack
 T₁—Output trans. (see text)
 1-2—Two-conductor cable

Send for Your
FREE
Copy of the **NEW 1954**
MIDWEST
TELEVISION and
RADIO Catalog

MIDWEST *Presents*

For 1954 a Completely NEW LINE of
21" and 27" TELEVISION

CONSOLES
TABLE MODELS

and
COMPLETE
CHASSIS

at
LOW FACTORY
PRICES



YOUR CHOICE OF EITHER 12 CHANNEL
VHF or All-Channel VHF-UHF Models

Buy your Television or Radio Direct from the Midwest Factory . . . on
30 DAYS TRIAL . . . Easy Terms . . . and at LOW FACTORY PRICES.
For 34 years Midwest, the world's largest and oldest exclusive Factory-
To-You radio and television manufacturer, has served hundreds of thou-
sands of satisfied customers all over the world.



EASY TERMS
— • —
30 DAYS
TRIAL



FACTORY-TO-YOU

Also—Powerful New 1954 World-Ranging
MIDWEST Series 16 RADIOS
In Beautiful Consoles and Complete Chassis

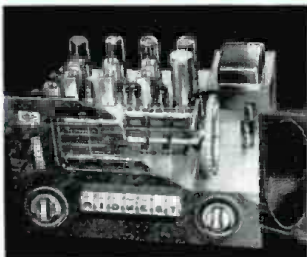

Once again Midwest offers its famous series 16 five band AM-FM radio chassis and the magnificent new Symphony Grand Radio-Phonograph with 3-Speed Automatic Inter-mix Record Player. Also, a complete line of clock radios, table radios, and portables.

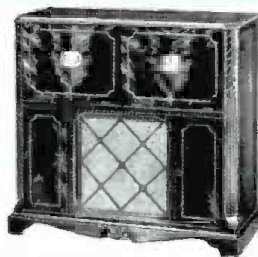

All models available in your choice of mahogany, walnut finish or blond lined oak.

● **WRITE IN NAME AND ADDRESS (PLEASE PRINT) ON COUPON OR 2c POSTCARD** ●

MIDWEST RADIO & TELEVISION CORP.
Dept. E-37, 909 BROADWAY • CINCINNATI 2, OHIO

Please send me your new FREE 1954 Catalog.

NAME _____
ADDRESS _____
CITY _____ ZONE _____ STATE _____

MIDWEST RADIO & TELEVISION CORP.

DEPT. E-37, 909 BROADWAY, CINCINNATI 2, OHIO

Now...

**multi-moded, all channel
tele-beam antenna**

For UHF or VHF or both close-in or fringe... under any receiving conditions the TELE-BEAM MULTI-MODED ANTENNA will guarantee your customers top reception on all channels.

Basic single Sabre Comet unit can be built up to meet any need; Add snorkel for an increase on VHF highs, stack these for more on all VHF channels, use diamond stacking bars for increase VHF and UHF gain, add UHF reflectors to increase the UHF gain and directivity

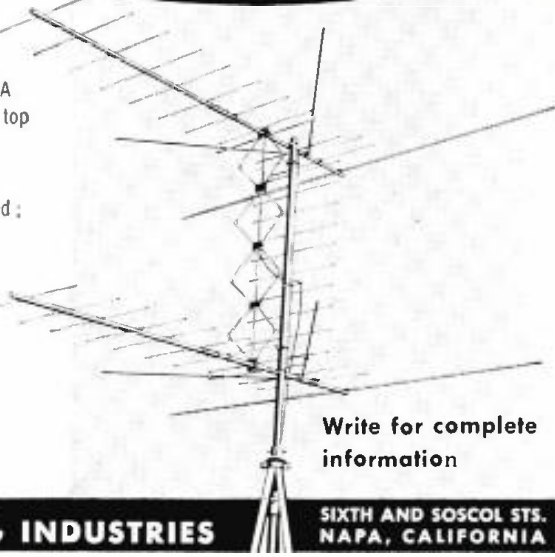

Write for complete information

tele-beam INDUSTRIES SIXTH AND SOSCOL STS. NAPA, CALIFORNIA

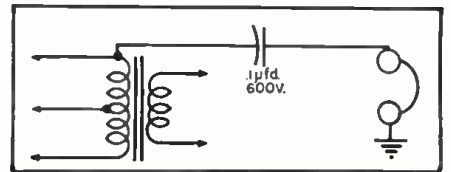

Fig. 3. A minimal headphone circuit setup.

to the speaker voice coil, silencing the speaker and connecting the receiver's output to the control box transformer. The 2-conductor cable connects to terminals 1 and 2 of Fig. 1B or Fig. 2B. Ordinary lamp cord or 2-conductor intercom cable can be used for this application.

Still further simplification can be achieved by omitting the individual volume controls, as shown in Fig. 2B. Headphone volume is then controlled by the receiver volume control and all headphone sets will operate at the same level.

If a push-pull output transformer is not available for the control box, a single-ended unit may be used with the headphones connected across the primary. Again, an extra pair of headphones may be connected in either series or parallel with the first pair. As mentioned before, the transformer characteristics are not at all critical—in fact, a small power transformer could be used, with the 6.3 volt heater winding serving as the voice-coil winding and the headphones connected either across the 117 volt winding or the high-voltage secondary.

Occasionally it is desirable to install a pair of headphones in the receiver without disturbing receiver operation. This may be done by connecting the headphones between one side of the output transformer primary and ground through a .1 µfd. isolating condenser, as shown in Fig. 3. A separate volume control could be used with this circuit, but is not recommended because it is apt to disrupt impedance relationships and introduce excessive distortion.

It was found that the headphones will operate after a fashion when connected directly across the voice-coil winding. However, the volume level is very low and operation in general is not as satisfactory as when one of the previously-discussed methods is used.

Construction of the control box is extremely simple and not at all critical. The 2-or 3-conductor cable can enter through a bushing with knots inside and out for strain relief or a connector of some kind may be used. The control box transformer can be of practically any size and any impedance rating which can be obtained easily and cheaply. The actual resistance of the volume controls can vary between very wide limits—try what you have before buying something new. Ordinary 2000 ohm headphones are ideal for this circuit, but here again, try what you have—it will probably work!

High-fidelity headphones are available and may be used for critical lis-

MORE JOBS than graduates

Electronic Engineers
Excellent opportunity for professional growth and advancement. Resisting and Advancing.

Demand for our engineering graduates exceeds supply. Effective placement. Study in this world-famed college established 1881. Quarters start March, June, Sept., Jan. Approved for Korean Vets.

Bach. Sci. degree in 27 months

Complete Radio Eng. courses... TV, UHF and FM. Also Mech., Civil, Elec., Chem., Aero. and Adm. Eng.; Bus. Adm., Acct. Small classes. Well-equipped labs. Modest costs. Prep. courses. Write J. McCarthy for Catalog and Campus View Book.

TRI-STATE COLLEGE

1614 College Avenue, Angola, Indiana

MOVING?

BE SURE

RADIO AND TELEVISION NEWS
FOLLOWS YOU. PLEASE
SEND YOUR CHANGE
OF ADDRESS TO

Circulation Department
64 E. LAKE ST. CHICAGO 1, ILL.

NOW... Save MORE on TUBES!

INDIVIDUALLY BOXED • FULLY TESTED • EACH TUBE GUARANTEED FOR SIX MONTHS

Type	Price	Type	Price	Type	Price	Type	Price
1B3	.68	6AK5	1.03	6BJ6	.53	6SK7GT	.50
1H5	.48	6AK6	.63	6BK7	.90	6SL7GT	.67
1L4	.59	6AL5	.42	6BL7	.90	6SN7GT	.60
1N5	.58	6AN4	1.30	6BQ6	.98	6SQTGT	.43
1R5	.62	6AQ5	.52	6BQ7	.90	6T8	.78
1S5	.51	6AQ6	.46	6BZ7	.99	6U8	.83
1T4	.58	6AR5	.41	6C4	.40	6V6GT	.50
1T5	.71	6AS5	.50	6CB6	.55	6W4GT	.48
1X2	.68	6AT6	.41	6CD6	1.46	6W6GT	.57
3Q5	.67	6AU6	.46	6F6GT	.50	6X4	.37
3S4	.58	6AV6	.40	6H6GT	.53	6X5GT	.38
3V4	.58	6B4G	.96	6J5GT	.45	6Y6G	.65
5U4	.43	6BA6	.49	6J6	.63	7N7	.59
5V4	.71	6BC5	.55	6K6GT	.45	12AT6	.41
5Y3G	.34	6BD5	.89	6L6G	.86	12AT7	.76
5Y3GT	.34	6BE6	.51	6L6GA	.86	12AU6	.46
6AB4	.50	6BF5	.70	6S4	.48	12AU7	.60
6AF4	1.25	6BG6	1.43	6SA7GT	.53	12AV6	.40
6AG5	.56	6BH6	.63	6SJ7GT	.48	12AV7	.75
						12AX7	.61

Each tube is performance-proven. 25% deposit must accompany all orders. Balance C.O.D. All prices F.O.B., N.Y.C. If remittance is made with order, you can deduct 2%. \$1.00 handling charge for orders under \$10.00. Subject to Prior Sale. Importer inquiries invited.

PHILLIPS TUBE CO. 2281 NOSTRAND AVENUE BROOKLYN 10, NEW YORK

tening. If such headphones are used, some attempt should be made to match impedances to minimize the possibility of introducing distortion.

Installing headphones in some such manner, as indicated, can provide a tremendous amount of relief to members of the family not desiring to listen to a particular program and will be a novelty for the children which will not soon wear off. —30—

"POP" McINTIRE

By C. HOWARD BOWERS

WE RECENTLY asked for data concerning "Old Time Wireless Operators" and the response has been terrific. From North, East, South, and West we are hearing from the old grads of 1912 and thereabouts and we would like to hear from YOU if you qualify as an old "Spark Wireless Man"!

Just prior to this issue we had word from a real Old Timer who, in all probability, is known to his neighbors as "Pop McIntire!" To be more formal, however, the subject of this sketch is M. W. McIntire, No. 10 South 2nd Street, Wilmington, N. C., co-owner and proprietor of the Electric Repair and Service Company, Inc.

Tuning back over the band some 46 years, Mr. McIntire got his feet wet in telegraphy with the A. C. L. Ry. Co. as messenger boy in their telegraph office. That was in 1907. In 1909, "Mc" joined the Navy at Norfolk, Virginia and soon found himself in the electrical school, Brooklyn Navy Yard, as landsman for electrician's mate. His first assignment for the Navy was at Brant Rock, Mass., along with other personnel, to test a big 100 kw. Fessenden transmitter between the cruisers "Birmingham" and "Salem," and if the equipment was acceptable, it was to have been installed at NAA, Washington, D. C., with "Mc" on the operating staff—but things were happening fast those days and before all tests were complete, the Telefunken people came along with a new 10 kw. outfit capable of doing the same work—so the Fessenden deal busted.

Back to Boston went our electrician's mate and duty aboard the "USS North Dakota" where a new 3 kw. Telefunken set was installed along with four operators—a full complement. McIntire stayed aboard also but as an intercom expert and concerned himself with telephones, gyros, fire-controls, bells, buzzers, etc. (What, no squawk boxes?) Duty aboard the "USS North Dakota" continued and in early 1912 a vacancy in the wireless gang made way for "Sparks" McIntire and a "trick" in the wireless shack. That was in March, 1912 and "Mc" was on watch the night the mighty liner "Titanic" sunk. Not being too sharp with code at that time he at least copied enough to know that something momentous was going on!

Mr. McIntire became ex-navy April 13, 1913 and returned to the A. C. L. Ry. Co. as installer and repairman of automatic signals. Then, in turn, a motion picture operator, a barnstormer with an old Jenny, a generator and magneto expert, until today we find him as co-owner of his own business and, outside of being their troubleshooter, sales and service man, night bookkeeper, and a few other odd jobs, he hasn't had much to do these last few years.

Good luck and continued success, "Pop" McIntire! —30—

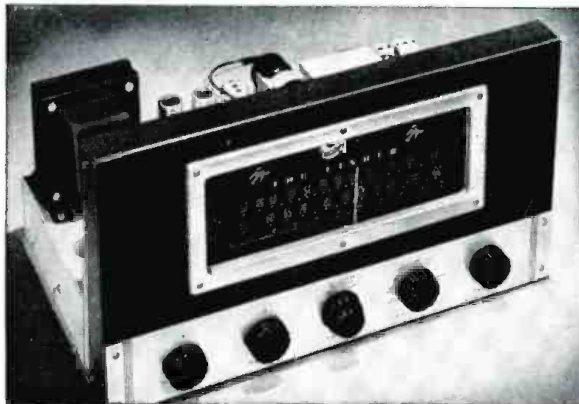

New!
And
Terrific!

FISHER

SERIES "70"

■ When the FISHER 50-R Tuner and 50-A Amplifier first appeared, two things promptly happened. We were besieged with orders; as well as with requests (from those with limited space) for a tuner with audio control facilities and preamplifier. Many also wanted a low-cost, high output, quality amplifier. It took us time, but here they are. *And they're tops!*

FISHER FM-AM Tuner MODEL 70-RT

■ Features *extreme sensitivity*: (1.5 mv for 20 db of quieting), works where others fail. Armstrong system, *adjustable AFC* plus switch, *adjustable AM selectivity*, separate FM and AM front ends. Complete shielding and shock-mounting on main and subchassis. Distortion less than 0.04% for 1 volt output. Hum level: better than 90 db below 2 volts output on radio, better than 62 db below output with 10 mv input on phono. Two inputs. Two cathode-follower outputs. Self powered. Six controls: BASS-AC, TREBLE, VOLUME, LOUDNESS, CHANNEL and EQUALIZATION, TUNING. \$184.50

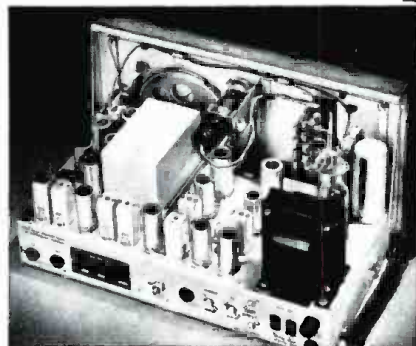

FISHER 25-Watt Amplifier MODEL 70-A

■ The FISHER Model 70-A Amplifier offers more *clean* watts per dollar than any amplifier made—25 *clean* watts for only \$99.50! The 70-A costs no more than "basic" 10-watt units, but has 150% *greater power!*



■ High output (less than 1/2% distortion at 25 watts; 0.05% at 10 watts). 1M distortion less than 0.5% at 20 watts; 0.2% at 10 watts. Uniform response ±0.1 db, 20-20,000 cycles; 1 db, 10-50,000 cycles. Power output constant within 1 db at 25 watts, 15-35,000 cycles. Hum and noise virtually non-measurable (better than 95 db below full output!) Four separate feedback loops, unique cathode and screen feedback circuit. Outstanding transient response, 8 and 16 ohm outputs. size: 6 1/4" x 10 1/4" x 6 1/8" high. \$99.50

PRICES SLIGHTLY HIGHER WEST OF ROCKIES

Write for full details

FISHER RADIO CORP.

39 EAST 47th STREET • N. Y.

SERVICEMEN

if you want the "low-down" on

COLOR TV

if you want to "fit into"

COLOR TV

you've got to get & read

PF INDEX

for January 1954!



**NOW
Published
MONTHLY**

**GET IT TODAY
AT YOUR PARTS DISTRIBUTOR**

get it! only 25¢

Electronorgan (Continued from page 72)

The tab switches were constructed from the components pictured in Fig. 32. Physicians' tongue depressors and switches from the antenna junction boxes of SCR-274-N command sets were used. Other switches may be used as long as the detent is a very weak one. Several manufacturers make telephone key-type switches which will work very well.

To make the tablets, cut off end sections from the tongue depressors and sand them smooth. Fill the wood either with shellac or by spraying with clear liquid plastic (*Krylon, Brusco*, etc.). After the tabs are quite dry, the lettering can be done with a *Wrico* or *Leroy* lettering set.

To fasten the tablet to the switch handle, the handle was first filed flat on top. Then a hole was drilled through it vertically, big enough for a 4-40 screw. With a similar hole through the tab, the screw passes through both and is fastened with a nut at the bottom. The setup would work as well with ordinary switches as they come from the parts supplier but the tabs lend a traditional appearance to the console and are easier to flick quickly in the course of playing. Fig. 36 is the rear view of the coupler panel which has been removed from the console and set on the organ bench.

Some thought was given to a reliable way to make the expression pedals operate the volume-control potentiometers. String or pulley systems are totally unreliable for this kind of hard service so a rack and pinion system was used. The pedals operate a lever which has vertical movement. To the end of the lever was pivoted a stick of wood; the two for the pedals are shown in Fig. 37. The sticks move vertically with the pedal movement. A section of the rack is screwed to the end section of each piece. The volume controls are mounted with brackets on the front

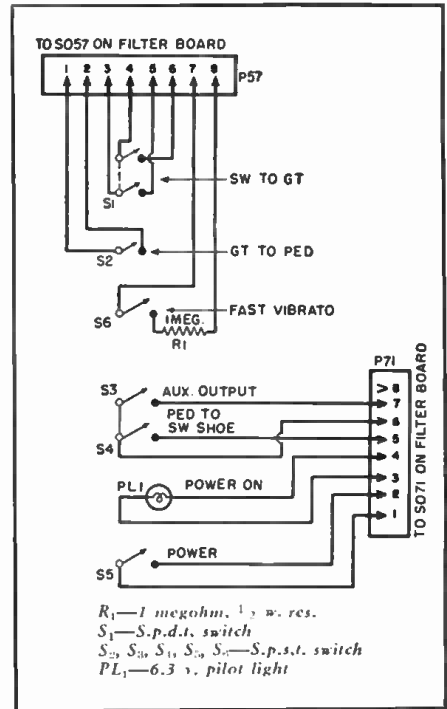

Fig. 34. Schematic diagram of coupler panel.

wall of the plugboard support and a gear is mounted on each. The pinion and gear are in contact so that as the stick and pinion move up and down the gear and control turn.

The same kind of arrangement can be used in almost any console selected. First determine the number of degrees the potentiometer must turn to give about 20 db attenuation (obtained with 9000 and 1000 ohms respectively on the two sides of the arm). Suppose this is 180 degrees. Then measure the total movement available from the stick due to pedal movement. Consider this figure to be 3 inches. To make the potentiometer move 180 degrees, the three inches must be 180/360 or 1/2 the perimeter of the pinion gear. It follows that the gear perimeter must be 6 inches and its pitch diameter is the perimeter divided by pi or 6/3.14 which equals about 1.9 inches. The nearest

Fig. 35. The coupler panel. It is located on front panel just above swell manual.



BUILD 15 RADIOS

ONLY

AT HOME \$19.95

With the New Improved 1954

Progressive Radio "EDU-KIT"

NOW INCLUDES
SIGNAL TRACER
and
CODE OSCILLATOR

- FREE TOOLS WITH KIT
- ABSOLUTELY NO KNOWLEDGE OF RADIO NECESSARY
- NO ADDITIONAL PARTS NEEDED
- EXCELLENT BACKGROUND FOR TV
- 10 DAY MONEY-BACK GUARANTEE



WHAT THE PROGRESSIVE RADIO "EDU-KIT" OFFERS YOU

The Progressive Radio "Edu-Kit" offers you a home study course at a rock bottom price. Our Kit is designed to train Radio Technicians, with the basic facts of Radio Theory and Construction Practice expressed simply and clearly. You will gain a knowledge of basic Radio Principles involved in Radio Reception, Radio Transmission and Audio Amplification.

You will learn how to identify Radio Symbols and Diagrams; how to build radios, using regular radio circuit schematics; how to mount various radio parts; how to wire and solder in a professional manner. You will learn how to operate Receivers, Transmitters, and Audio Amplifiers. You will learn how to service and trouble-shoot radios. You will learn code. You will receive training for F.C.C. license.

In brief, you will receive a basic education in Radio exactly like the kind you would expect to receive in a Radio Course costing several hundreds of dollars.

THE KIT FOR EVERYONE

The Progressive Radio "Edu-Kit" was specifically prepared for any person who has a desire to learn Radio. The Kit has been used successfully by young and old in all parts of the world. It is not necessary that you have even the slightest background in science or radio.

The Progressive Radio "Edu-Kit" is used by many Radio Schools and Clubs in this country and abroad. It is used by Armed Forces personnel and veterans for training and rehabilitation.

The Progressive Radio "Edu-Kit" requires no instructor. All instructions are included. All parts are individually boxed, and identified by name, photograph and diagram. Every step involved in building these sets is carefully explained. You cannot make a mistake.

PROGRESSIVE TEACHING METHOD

The Progressive Radio "Edu-Kit" comes complete with instructions. These instructions are arranged in a clear, simple and progressive manner. The theory of Radio Transmission, Radio Reception, Audio Amplification and servicing by Signal Tracing is clearly explained. Every part is identified by photograph and diagram. You will learn the function and theory of every part used.

The Progressive Radio "Edu-Kit" uses the principle of "Learn by Doing". Therefore you will build radios to illustrate the principles which you learn. These radios are designed in a modern manner, according to the best principles of present-day educational practice. You begin by building a simple radio. The next set that you build is slightly more advanced. Gradually, in a progressive manner, you will find yourself constructing still more advanced multi-tube radio sets, and doing work like a professional Radio Technician. Altogether you will build fifteen radios, including Receivers, Transmitters, Amplifiers, Code Oscillator and Signal Tracer. These sets operate on 105-125 V. AC DC.

THE PROGRESSIVE RADIO "EDU-KIT" IS COMPLETE

You will receive every part necessary to build 15 different radio sets. Our kits contain tubes, tube sockets, chassis, variable condensers, electrolytic condensers, mica condensers, paper condensers, resistors, line cords, selenium rectifiers, tie strips, coils, hardware, tubing, etc.

Every part that you need is included. These parts are individually packaged, so that you can easily identify every item. Tools are included, as well as an Electrical and Radio Tester. Complete, easy-to-follow instructions are provided.

In addition, the "Edu-Kit" now contains lessons for servicing with the Progressive Signal Tracer, F.C.C. instructions, quizzes. The "Edu-Kit" is a complete radio course, down to the smallest detail.

TROUBLE-SHOOTING LESSONS

Trouble-shooting and servicing are included. You will be taught to recognize and repair troubles. You will build and learn to operate a professional Signal Tracer. You receive an Electrical and Radio Tester, and learn to use it for radio repairs. While you are learning in this practical way, you will be able to do many a repair job for your neighbors and friends, and charge fees which will far exceed the cost of the "Edu-Kit". Here is your opportunity to learn radio quickly and easily, and have others pay for it. Our Consultation Service will help you with any technical problems which you may have.

FREE EXTRAS

- ELECTRICAL AND RADIO TESTER • ELECTRIC SOLDERING IRON • BOOK ON TELEVISION • RADIO TROUBLE-SHOOTING GUIDE • MEMBERSHIP IN RADIO-TV CLUB • CONSULTATION SERVICE • QUIZZES • TRAINING FOR F.C.C. LICENSE

MAIL TODAY: Your Order Shipped Same Day Received Send further information.

Send me the "Edu-Kit" with 10 Day Money-Back Guarantee—include All FREE Extras.

- Check or M.O. enclosed—postage prepaid
 C.O.D. (U. S. Only)—I will pay postage

Outside U. S. A.—No C.O.D.'s; send check on U.S. bank or intern'l M.O. for \$19.95. Postage prepaid. "Edu-Kit" for 210-250 V. AC/DC \$22.45.

NAME _____
ADDRESS _____

PROGRESSIVE "EDU-KITS" Inc.
497 UNION AVE., Dept. RN-26, Brooklyn 11, N. Y.

Attention!! • EXECUTIVES
• SALESMEN • PUBLIC OFFICIALS
• POLICEMEN • FIREMEN • OUTDOOR MEN
REPORTERS • FIELD INSPECTORS • DOCTORS • LAWYERS, ETC.

DICTATE IN YOUR CAR



with
ATR

INVERTERS

for changing your battery current to
A.C. Household CURRENT
Anywhere

in your own car!!

ATR INVERTERS . . . especially designed for operating standard 110 volt A.C. Tape Recorders, Wire Recorders, Dictating Machines and Electric Razors IN YOUR CAR.



Announcing!
NEW MODELS
NEW PRICES

EASY TO INSTALL
EASY TO OPERATE

A VALUABLE TIME SAVER FOR:

- TRAVELLING SALESMEN—Dictate reports in your own car. Send your dictated reports in daily to your home office or sales manager.
- FIELD INSPECTORS & INVESTIGATORS—Dictate your field inspection reports in the field—on the spot. Give the complete story factually and completely. Include your clients recording also.
- DOCTORS—Dictate and record your house calls on the completion of your call while everything is fresh in your mind. Make these records for transcription by your office girl.
- LAWYERS—Record evidence in the field at your client's premises. Obtain factual and complete witness reports, etc.
- EXECUTIVES—Dictate in your car all business matters while on trip for pleasure or business.
- PUBLIC OFFICIALS—Dictate complete field reports in your car. Obtain recorded opinions and expressions of Mr. Public in the Field. Dictate your business reports while traveling.
- POLICE SQUAD CARS—Dictate accident reports right on the scene, complete and factual. Include witness recordings at the same time. Have the complete story available by dictation.
- FIRE TRUCKS—Dictate your fire reports factually and complete on the scene and include witness reports. Have the complete story.
- AMBULANCES—Dictate complete reports of your ambulance run. Include witness recordings, etc.
- ADVERTISING AGENCIES—Use AC operated animated or illuminated displays in or on the car.
- FISHERMEN & HUNTERS—Use your electric razor on camping trips, operating in your car. Also small home radios and other electrical or electronic items.
- CAMPERS—Make your camping and outing trips more exciting using mix-masters, tape recorders, or wire recorders operating from your car battery.
- WAREHOUSE & MATERIAL HANDLERS—Dictate your inventory and material handling reports on the scene, in the warehouse, yard, or wherever you may be.

FREE !! ATR INVERTER!

Given away every 30 days to lucky registrant of preceding month. Mail or postcard as your registration request today!

Announcing!

NEW ATR INVERTERS

New models New features New prices

WRITE FOR NEW FREE LITERATURE

See your jobber or write factory

✓ NEW MODELS ✓ NEW DESIGNS ✓ NEW LITERATURE



"A" Battery Eliminators, DC-AC Inverters, Auto Radio Vibrators

AMERICAN TELEVISION & RADIO Co.

Quality Products Since 1931

SAINT PAUL 1, MINNESOTA—U. S. A.

The First Practical, Understandable Book About TRANSISTORS

distributed by
HOWARD W. SAMS & CO., INC.

NEW COYNE PUBLICATION

"TRANSISTORS AND THEIR APPLICATIONS IN TELEVISION-RADIO-ELECTRONICS"

by Louis E. Garner, Jr.

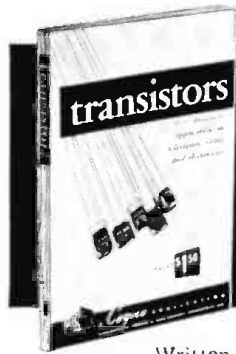

The "inside story" of Transistors for Servicemen, Engineers, Amateurs and Experimenters

Written by an authority on the subject. Explains in easy-to-understand language the theory and practical applications of Transistors. Clears up common misconceptions; clarifies Transistor circuitry, installation, testing techniques, theory and servicing. An important book for everyone in Electronics.

CONTENTS

Chapt. 1: History of Transistor development and its implications for the electronic industry. Chapt. 2: Non-mathematical explanation of how Transistors work; description of basic types. Chapt. 3: Physical and electrical properties of transistors. Chapt. 4: Transistor amplifier circuits. Chapt. 5: Transistor oscillator circuits. Chapt. 6: Special Transistor circuits (D.C. amp., R.F. det., Clippers, Phase Inverters, etc.). Chapt. 7: Transistor Components (sub-miniature parts and power supplies). Chapt. 8: Care and servicing of Transistors. Chapt. 9: Practical Transistor circuits (experimental circuits with parts values; audio and r.f. circuits). Chapt. 10: Reference data; commercially available Transistors and their characteristics, etc.

Have ALL the latest information on Transistors in this authoritative, low cost book—it's a "must" for your library.

100 PAGES. 5 1/2 x 8 1/2" \$1.50
ORDER CTB-7. Only...

ORDER TODAY

HOWARD W. SAMS & CO., INC.

Order from your Parts Jobber today, or write direct to Howard W. Sams & Co., Inc. 2203 East 46th St., Indianapolis 5, Ind.

My (check) (money order) for \$..... enclosed. Send..... copy(ies) of "Transistors" (CTB-7) at \$1.50 per copy.

Name.....

Address.....

City..... Zone..... State.....

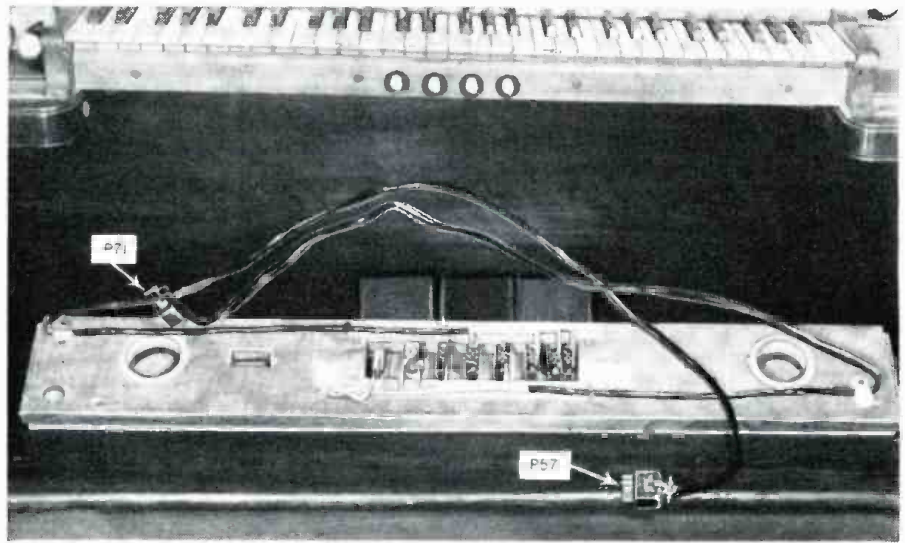

Fig. 36. Rear view of coupler panel, removed from organ and set on organ bench.

standard gear diameter is 2 inches. Gears and racks may be obtained from local sources or from a distributor in one of the larger cities. The writer used 48-pitch racks and pinions made as standard brass items by *Boston Gear Works* and distributed widely. The rack comes in 2-foot lengths and the gears have hubs with 1/4" holes. The setscrew holes must be punched and tapped.

The final items which must be constructed are the filters themselves. These were made up in *Bud* "Mini-boxes," 5" long by 2 1/4" square, with *Amphenol* 86-CP8 octal male connectors in the bottom of each. Use a 1 1/16" keyed socket punch to make the holes. Fig. 28 shows three of the filters with the box covers removed.

The filters are diagrammed in Fig. 27. Most of them are quite simple and can be wired right to the connector pins. The boxes need not be grounded. It should also be remarked that it is really not necessary to ground the normally-closed relay contacts of Figs. 23, 24, and 25 either.

The 250 mhy. inductors called for in some of the filters are made from *Stancor* A-3877 output transformers. Remove the frame and take out the core laminations which go across the open side of the "E" laminations. This gives about 350 mhy. Now remove the outside lamination on each side of the

stack. This gives about 260 to 300 mhy. If an impedance bridge is available, the inductance can be set exactly by pushing the entire remaining core slightly out of the winding. No more than 1/16" of movement is necessary.

The 800 mhy. units were made by the writer from scrap transformers by removing laminations. On the 250 mhy. units the frame can be replaced with the open end of the "E" core facing the open end of the frame and the closed end seated firmly in the closed end of the frame. Bend down the original clinching ears to keep things in place and then mount the inductors normally.

Constructing the "Electronorgan" is a long job which most builders will want to spread over a period of months. When finished, however, the reward will be commensurate with the time spent as this instrument provides an authentic pipe-organ sound and the fine musical expressiveness of instruments costing many dollars more.

Editor's Note: The photograph, Fig. 16, Part 2, was incomplete in that the "C" chassis at the far right contained only four tubes instead of the five tubes specified for this particular chassis. The photograph was taken prior to this change and the discrepancy should have been mentioned in the caption.

-30-

Fig. 37. Method of connecting expression pedals to operate the volume control.

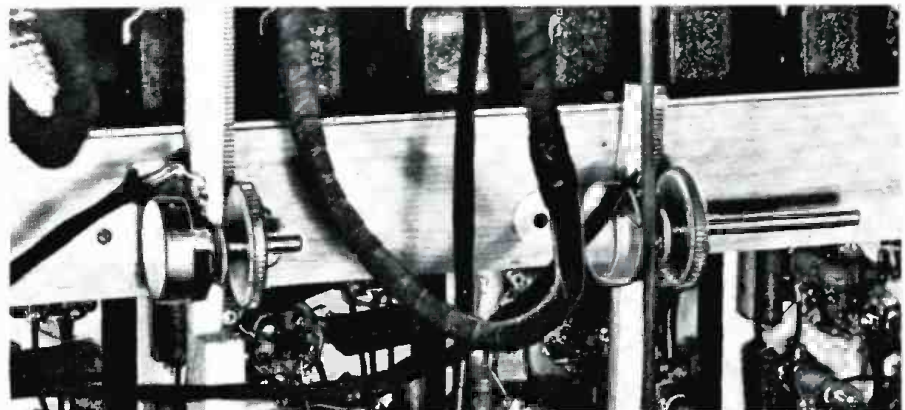

Now! RAD-TEL Tubes & Parts At Savings!

HI-VOLTAGE R.F. COIL
4500 VOLTS RF TRANSFORMER



Ideal for T.V. and O-scilloscope power supplies, using 50 to 75 tubes. This buy is too BIG to be beaten!
List price \$7.50
79c

Smashing Reductions on FP CONDENSERS



All famous makes - save plenty on these top quality FP Condensers. Made by leading manufacturers. You can't miss - these values are hits no matter how you look at them!

CERAMICON KIT
1 kit of 50 assorted ceramic discs, biliates, tubular condensers. All good makes popular sizes, used in T.V. and F.M. sets. A MUST kit!
List price \$10.00
\$1.99



DRY ELECTROLYTIC CAPACITORS
10 Mfd 500 WV 600 Peak
A higher rated condenser at a lower price. Box of ten (10).
List price \$2.95
And we're not fooling around. OUR price is **\$2.95**



FILTER CONDENSER
20-20 Mfd. 450 V.
Color-coded leads. Ideal for use where impossible to use metal cans. For top performance at a give-away price. List price \$3.10.
49c



BIG CONDENSERS
500 Mfd 12 V.
Famous name manufacturers. Max. value in size. Package of ten (10) \$2.95
List price \$2.00
35c EA.



CAN ELECTROLYTICS

Capacity	DC Working Voltage	Price
40-10-10-100	450-150-150-200 Bendix	\$.89
40-40	450-150	.99
250-1000	10-6	.49
40	450 Sprague	.49
60-10-10-20	450-150-150-150	.89
80-10-10	450-150-450 Aerovox	.99
20-8-8-8	450-150-150-250	.59
30-30-20	450-450-25 Aerovox	.79
80	500 Aerovox	.79
35	450 Philco	.49
15-15-20	450-150-25 Aerovox	.59
40-10-100	450-150-200	.79
40-40	450-50 Aerovox	.59
15	450 Philco	.39
10	450 Aerovox	.39
10-20	150-25 F.P.	.39
10-8-8-8	450-150-150-150	.49

National Turret T.V. BOOSTER



Made by National, famed for quality and precision communications equipment. Turret selects each channel. Completely self-contained including tube and selenium rectifier for use in metal cabinet. Housed in factory-sealed cartons with complete instructions.
List price \$39.95
\$9.95

High-Voltage POWER SUPPLY
4500 Volts
6 WA
12A07 oscillator
rectifier
Completely wired, enclosed in slotted metal case, removable cover. Improve performance of your scope, use as R.F. high voltage supply.
BRAND NEW... \$2.95
Kit of 2 tubes for above... \$1.08.



25 Paper BY-PASS CONDENSERS
An assortment of 25 by-pass condensers, made by leading manufacturers. Top quality. Most popular sizes and voltages. Values out to 2 MFD 200 to 1000 VDC.
KIT OF 25
99c



LOWER PRICES THAN EVER BEFORE!
Famous Standard Coil Cascade Tuner
Famous Standard Tuner T.V. front end. Double-tuned with a great reduction in noise. A MUST for fringe area reception. Includes tubes 6BK7 or 6BQ7 or 6BQ7 or 6BQ7 or 6BQ7
\$18.95
List price \$34.50

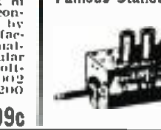

ALL BRAND NEW PARTS!

TRIMMER KIT
Compression type mica for radio, F.M., T.V. Very few duplications. Don't let this chance pass you by!
25 FOR... **99c**



FILAMENT TRANSFORMER
6.3 V @ 1.2 A

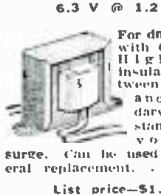

For dimmer use with 6W3, etc. High voltage insulation between primary and secondary to withstand high voltage surges. Can be used for general replacement.
List price - \$1.75

REA Type FLYBACK TRANSFORMER
Type 21571
Lowest net price elsewhere - \$4.70
At this give-away price, order in quantities, while they are available. Each **95c**



Vertical OUTPUT TRANSFORMER
Very popular, used in most T.V. sets. Well-known manufacturer. Matches vertical output tube to the deflection yoke, 10 to 1 ratio. A terrific buy on a top performer... **95c**
List price - \$4.50

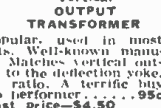

BIG SAVINGS YOU CAN'T PASS BY!
70% YOKE (Manufactured by Todd)
Very good value, makes conversion profitable and simple. Get 'em while they're still around!... **\$1.95**
List price - \$7.50



70% to 90% OFF ON TUBES!

All Tubes Individually Boxed! Same Day Service! Check This List for Fully 1-Year Guaranteed Tubes.

Type	Price	Type	Price	Type	Price
0A2	.74	6B86	.43	12BA6	.38
0B2	.81	6B06GT	.79	12BA7	.60
0C3	.72	6B07A	.90	12BD6	.45
0D3	.70	6BZ7	.90	12BE6	.39
0Z4	.55	6C4	.37	12BF6	.39
1A5GT	.30	6C5GT	.39	12BH7	.63
1A7GT	.47	6C6	.58	12BY7	.65
1A2X	.62	6C86	.44	12BZ7	.65
1B3	.68	6D06G	1.11	12C8	.34
1B7GT	.30	6D6	.45	12E6GT	.42
1C5GT	.43	6E5	.48	12J7GT	.59
1E7	.29	6F5GT	.39	12K7GT	.59
1G6	.24	6F6	.59	12S8	.62
1H4G	.30	6G6G	.52	12SA7GT	.65
1H5GT	.49	6H6GT	.41	12SF5	.50
1L4	.46	6J7	.43	12S7	.67
1LN5	.89	6J6	.52	12SK7GT	.63
1N5	.67	6J7G	.43	12SL7GT	.47
1P5	.57	6K5	.47	12SN7GT	.52
1Q5	.58	6K6GT	.37	12SQ7	.56
1R5	.49	6K7	.44	12SR7	.49
1S4	.79	6L6	.64	12V6GT	.46
1S5	.43	607	.45	12V7	.30
1T4	.49	6S4	.38	14W7	.30
1T5	.53	6S8	.53	19B6G6	.95
1U4	.49	6SA7GT	.43	19C8	.70
1U5	.41	6SD7GT	.41	19T8	.69
1V7	.53	6SF5GT	.46	19V8	.79
1X2A	.41	6S7GT	.41	2A4	.53
2A3	.30	6S7GT	.49	25AV5	.83
2A4G	.24	6S7GT	.41	25B06GT	.79
2W3	.38	6J7GT	.41	25L6GT	.39
2X2	.24	6S7GT	.48	25Z5	.66
3A4	.59	6S7GT	.52	26	.45
3E5	.46	6S7GT	.37	27	.39
3Q4	.48	6SR7GT	.45	35	.58
3Q5GT	.49	6S7	.42	3B5	.40
3V4	.49	6T4	.99	3C5	.39
3V5	.51	6T8	.56	3G6	.41
5U4G	.50	6U4	.60	35L6GT	.41
5W4	.50	6U5	.44	35W4	.37
5Y3	.37	6U6	.59	35Z5GT	.47
6A4	.44	6U8	.61	36	.39
6AF4	.90	6V6GT	.39	41	.42
6AG5	.48	6W6GT	.44	42	.42
6AG7	.69	6W6GT	.37	43	.55
6AH4	.57	6X7	.37	45	.55
6AJ5	.65	6X5GT	.37	45	.55
6AK5	.55	6X8	.75	45Z3	.44
6AL5	.38	6Y6G	.48	45Z5	.49
6AQ5	.39	7A4	.47	50A5	.79
6AQ6	.37	7A6	.69	50B5	.43
6AR5	.37	7A7	.69	50C5	.39
6AS5	.50	7AF7	.53	50L6GT	.61
6AT6	.37	7B4	.44	50Y7	.50
6AU4	.68	7B6	.69	53	.24
6AU6	.38	7C5	.69	57	.58
6AV5	.83	7E6	.30	58	.60
6AV6	.37	7N7	.46	70L7GT	1.09
6AX4	.53	7X7	.70	76	.44
6B4G	.64	7Y4	.69	77	.57
6B46	.39	12A8	.61	78	.47
6BA7	.57	12A5	.37	80D6	.35
6BC5	.49	12AT6	.37	83V	.68
6BD5GT	.59	12AT7	.66	85	.59
6BD6	.45	12AU6	.38	117L7	1.09
6BE6	.39	12A7	.54	117Z3	.37
6BF5	.41	12AV6	.39	807	1.19
6BF6	.37	12AV7	.63	1274	.30
6BG6G	1.25	12AX4	.56	2050	.89
6BH6	.46	12AX7	.99	100DFW	.59

Horizontal Output TRANSFORMER
Type 204T1
A horizontal output transformer designed for deflection circuits employed in rf operated high-voltage supplies. Intended for 30 mmf. nodule-deflection kinescopes. Used with RCA Deflecting Yokes 2011D1, 2011D2, 2011D1 or 2011D2.
\$2.95
List price - \$13.95



RESISTORS
(Assortment of 200)
Standard RTMA Coated or Value Printed. Uninsulated. 1/2 Watt, 1 Watt, 2 Watt, and Same to 10 Watt. RAD-TEL SUPER BUY!!!
Assortment of 200... **\$1.39**
List price - \$10.00



Kit of 50 MICA CONDENSERS
All popular sizes of mica condensers. In regular and silver construction. For FM and T.V. use... **\$1.95**
List price - \$12.50

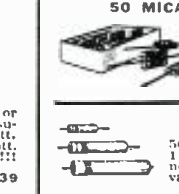

Hi-Voltage T.V. CONDENSERS
500 mmfd 10KV. \$.39 ea.
500 mmfd 15KV. .49 ea.
500 mmfd 20KV. .49 ea.
500 mmfd 30KV. 1.59 ea.



5" Utah AUTO SPEAKER
3-4 Ohm V.C. - 4 Ohm Field
Exceptional price for a standard well-known speaker. Designed for auto radio use.
79c
List price - \$5.05



4x6 Inch Quam P.M. Speaker
Athlet 5 Field. Lowest price oval speaker ever offered. Can be used in almost every table model television set. Exceptional value and high quality.
\$1.95
List price - \$4.75



12" Magnavox P.M. Speaker
Heavy Magnet. Delivers high volume and clear tone. Ideal for radio and P.A. use, and replacement of small speakers - for better tone.
\$5.95
List price - \$11.50



Knob KIT (Choice Groups!)
Assortment of home, auto, and T.V. knobs. All colors - plastic, wood and bakelite knobs. Bag of 50... **\$1.29**
Super Bag of 100 extra val. 1.95
Sells from 12c to 18c each.



Volume Control Kit
Kit of 10 includes 3 wire-wound, 2 dual post, 5 carbon
The price of one (1) for the quantity of ten (10). Short and long shaft. PER KIT... **\$1.79**



AUTO VIBRATORS
(Kit of 5)
Syn. and non-syn. Mfd. by Oak Mfg. Electronic. others. Four (4) and six (6) pin. Assortment... **\$1.95**



Army - Navy HEADSETS
Individually boxed. Very comfortable. Meets with Army and Navy specifications.
Ea. Per set... **\$2.95**
List price - \$16.00



Kit of BATTERY PLUGS
Polarized, 3, 4, 5, etc. 50 for... **\$1.69**



SOLDER LUG STRIPS
Kit of 48 - very usable assortment of solder lug terminal strips. Brand new. Unusually low value!
Comp. Kit of 48... **89c**
List Price \$4.00

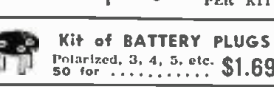

T.V., RADIO, and F.M. COIL KITS
Kit for television service men and experimenter consisting of width coil, peak-to-peak, 1.5 m.e. ratio detector, and 21.9 m.e. IF coil.
TV. Standard kit of ten (10)... **99c**
TV. Super value; not duplicated.
Broadcast and short-wave, mid-jet to multi-band replacement coils. Kit of 25... **\$1.85**
IC kits include IF, Osc., IF, and detector coils. Kit of 10... **99c**
IC. Super value; not duplicated.
Kit of 25... **\$1.85**
IC kits include IF, Osc., IF, and detector coils.

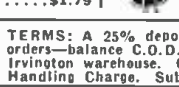

Send For OUR FREE Illustrated Folder!



TERMINAL STRIPS
Assortment of 50 terminal strips - screw type. Kit contains wide selection to meet every design.
Kit of 50... **89c**
2, 3, 4 and 5 screw strips.



Kit of 50 MICA CONDENSERS
All popular sizes of mica condensers. In regular and silver construction. For FM and T.V. use... **\$1.95**
List price - \$12.50



Kit of 100 Insulated RESISTORS
50 - 1/2 and 1 watt. 25 - 1 watt, 25 - 2 watt. All new, all clean. Good value... **\$2.65**
List price - \$15.00



Kit of 10 Insulated RESISTORS
50 - 1/2 and 1 watt. 25 - 1 watt, 25 - 2 watt. All new, all clean. Good value... **\$2.65**
List price - \$15.00

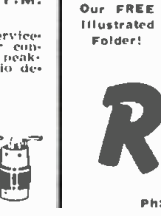

RAD-TEL TUBE CO.

"Integrity is Our Chief Asset!"
Ph: Essex 5-2947, Dept. RN-1, 115 Coit St., Irvington 11, N. J.

Here's how to GET MORE WORK OUT OF YOUR Oscilloscope!



**A complete,
easily understood guide to
using the handiest, most profit-
able service instrument of all**

MODERN OSCILLOSCOPES AND THEIR USES

By Jacob H. Ruiter, Jr.

of Allen B. Du Mont Laboratories, Inc.
326 pages, 370 illustrations. Price \$6.

Oscilloscopes are gold mines for servicemen who learn to use them fast, fully and accurately on all types of work—and here at last, is a book that really shows you how.

In clear, easily understood terms, it teaches you when, where and exactly how to use the oscilloscope . . . how to interpret patterns . . . how to use your 'scope to handle tough jobs easier, faster, and better.

It contains no involved mathematics—no complicated discussions. Instead, it gets right down to "brass tacks" in explaining how oscilloscopes operate. Then you learn exactly how to use them in lab work and on all types of AM, FM, and television service—from locating troubles to handling tough realignment jobs.

Each operation is clearly explained step by step. You learn to determine just where and how to use the 'scope on a specific job; how to make connections and adjust the circuit components; how to set the controls; and HOW TO ANALYZE OSCILLOSCOPE PATTERNS fast and accurately. 370 illustrations including dozens of pattern photos make things doubly clear.



No other type of specific service training can mean so much to you in boosting your efficiency and earning power! Send coupon NOW for 10-day FREE examination!

'SCOPE EXPERTS
get better jobs
. . . bigger pay!

**PRACTICE
10-DAYS
FREE!**

Dept. RN-14,
RINEHART BOOKS, Inc.
Technical Division,
232 Madison Ave., New York 16, N. Y.

Send MODERN OSCILLOSCOPES AND THEIR USES for 10-DAY FREE EXAMINATION. If book is satisfactory, I will then send you \$6.00 promptly in full payment. If not, I will return book postpaid in good condition and owe you nothing.

Name

Address.....

City, Zone, State.....

OUTSIDE U.S.A. \$6.50, cash only. Money back if you return book within 10 days.

RADIO-TV Service Industry News

AS REPORTED BY THE
TELEVISION TECHNICIANS LECTURE BUREAU

THE recent National Appliance and Radio-TV Dealers Association television service study, conducted among a representative group of that association's members, indicated that servicing dealers are in complete accord with the whole of the independent servicing fraternity that education is the greatest need of the servicing industry.

The NARDA survey developed two categories of education needed: (1) *The education of the public* on the importance of calling reputable, established, reliable service companies when electronic service is needed, and (2) *The self education of service operators* on the necessity for operating their businesses on a high ethical plane and along sound business lines to make a profit.

The entire electronics industry is aware of the pressing need for public relations programs that will upgrade the set owning public's thinking and opinions of TV and other home electronic service. Many fine programs are being carried out by tube manufacturers aimed at establishing better relations between independent service and the public. Booklets and flyers are being made available by many other manufacturers to be used either as mailing pieces or to be handed out individually to service customers and set owners.

The Radio Electronics-Television Manufacturers Association and the Better Business Bureau developed a TV service folder that has been used by many dealers in their service public relations programs. Some BBB's have developed service brochures independently and many of the leading service associations have prepared excellent service customer booklets.

These are all positive steps in the direction of educating the set owning public about the requirements for competent technical service; the need for TV sets to have the benefit of the best possible service, and that good service cannot be cheap service. It clearly demonstrates the broad interest of manufacturers and trade associations in helping to foster better relations between the service industry and the public.

But in the final analysis and irrespective of all the advertising and direct mail programs that are instituted to help the service industry, a customer's opinion of service will always hinge on a contact with one man or one organization called in to service a set. The key public relations contact the service industry has with the public is the technician who calls to fix a set. To the customer, this technician is the service industry. If they like him and like the way he conducts himself and the service he gives they will consider the business of servicing as an honorable activity. If he offends the customer, does a sloppy job on the set, or makes a charge for service and parts that is not supported by a logical itemized statement of particulars, the entire servicing profession will suffer in the eyes of this customer.

Some alert, aggressive service organizations minimize the chance of customers going sour because of displeasure over some act of their home service technicians, by using an automatic, direct mail follow-up the day after service calls are completed. They have found that some types of customers who get sore over real or fancied wrongs committed by technicians will nurse their grievances and then call some other service company the next time they need service. By inviting the customer to report any displeasure or dissatisfaction that may have arisen over the call they more or less automatically ferret out and placate those customers who might otherwise have been lost.

Public Relations Responsibilities

Every man who is engaged in servicing electronic equipment in the home has a moral responsibility to the public and to all other men engaged in the service business to so conduct himself in his relations with service customers that they will respect the type of work he is doing and the men engaged in it. This holds true for the technician working in a large service company and for the man who works alone in a one-man service business.

The public is a hard taskmaster and especially so when it is necessary to

buy service on anything used in the home. The TV service technician has to be capable of taking a lot of "gaff" from service customers and to take it with a smile. It is part and parcel of a service business. Yet, for the man who has learned how to become interested in people, the give and take of service contacts becomes a pleasurable experience. He has learned how to use a "soft answer," and he has found that a preponderantly large percentage of service customers are fair and reasonable.

Technicians who are employed in well-managed service organizations usually have a decided advantage over the man who works alone because of the stimulating effect they get from their discussions of customer contacts with their employers and with their fellow technicians. Many independent technicians, working alone in their one-man service businesses, have found that service association activity has been very helpful in furnishing the stimulus a man gets from discussing his technical and business problems with other men engaged in the same activity.

Service Associations

During the past two years there has been a phenomenal growth in the interest of service people in service association possibilities. Many small, local associations have been organized expressly for the self-help that can be generated through cooperative effort.

Men who have joined in the formation of these associations with the definite determination to make a personal contribution in the way of eliminating practices in their own businesses that are contrary to the common good of the service industry, have gained immeasurably from their association contacts.

While it is strictly illegal for any group of competitive businessmen to agree to adhere to a schedule of fixed prices, common sense will inspire a man to maintain certain minimum charges when it is definitely proven to him that his business must get those charges if it is to continue to exist.

The largest number of service associations now in existence are fairly informal affairs. They are usually made up of the managers of the leading service businesses in an area who started getting together to discuss technical as well as business operating problems in TV servicing. In many cases the nucleus of an association developed when three independent service operators got together to pool their experiences on handling service on certain makes of TV receivers. After a few meetings in which these men found they had benefited greatly by this method of pooling experience, they invited other service people whom they respected to join in one of their weekly meetings. In this way an association was born. It was created not to get something for nothing from

(Continued on page 126)

Easy, fast
way to cut
"Key" and "D"
openings
in chassis



...with new GREENLEE Radio Chassis Punches

Now, in 1½ minutes or less make perfect "Key" or "D" holes for sockets and other equipment. Simply insert GREENLEE Punch and turn with an ordinary wrench . . . get a "clean" opening in a hurry! Write today for details on these as well as GREENLEE Radio Chassis Punches for round and square openings. Greenlee Tool Co., 1481 Columbia Ave., Rockford, Illinois

No. 732 "Key" Punch



No. 733 "D" Punch



★ ★ ★ ★
EXTRA!

MATTISON NEWS

10 WEST 181st ST., NEW YORK 53, N. Y. • CY 8-1400

... the world's largest
manufacturer of custom-
built Television Sets!

All 630 Chassis Now Out Of Date! Only MATTISON SILVER ROCKET 630 Is So NEW.. No Drift! UHF-VHF-DX!

Picture and sound will drift apart on any 630 regardless of make or age... except the NEW, Syncromatic Tuned Mattison 630 Silver Rocket!

Syncromatic Tuning is an exclusive Mattison 630 circuit. Select your channel . . . sound is automatic! Only the Mattison 630 "Silver Rocket" features Syncromatic Tuning, eliminates drifting apart of picture and sound on UHF, VHF & DX reception.

Only the Mattison 630 Chassis has Syncromatic Tuning and an all-channel tuneable built-in Booster that increases signal strength up to ten times! For complete details write: Mattison Television and Radio Corporation, Engineering Department, 10 West 181st Street, New York 53, N. Y.

NOW! BECOME EXPERT AT RADIO- TELEVISION IN 4 EASY STEPS!



Complete Self-Training Library in RADIO and TV by Famous Experts — Takes You BY SIMPLE STEPS From Basic Theory to Problems of Repair, Installation, Color TV, etc.

NOW you can do ANY Radio-TV installation, service, or repair job like an expert; operate field-testing equipment; understand problems of TV, FM-AM transmission, etc. Step into a good-paying job—or start your own service business. Train yourself AT HOME . . . IN SPARE TIME . . . with the McGraw-Hill Radio and Television Servicing Library.

2296 Pages—
1611 Illustrations

The men who wrote this complete 4-volume Library are among the outstanding radio and TV instructors in America today. Every detail is clearly explained in over TWO THOUSAND PAGES of step-by-step instruction and over SIXTEEN HUNDRED "how-to-do-it" illustrations, cross-section diagrams, etc. The review questions and answers "nail down" everything you learn. At-a-glance "trouble-shooting" charts show how to diagnose instantly any radio or TV breakdown . . . and how to repair it expertly and quickly. The Library will pay for itself many times over. It gives all you need to know for FM and TV in the FCC's 1st-class license exam; gives an experienced technician more confidence and skill.

SEND NO MONEY

Mail coupon below to examine complete four-volume Library FREE for 10 days. No obligation. Or you may examine individual books FREE for 10 days by checking the proper boxes in coupon.

PARTIAL CONTENTS ESSENTIALS OF RADIO.

800 pages, 433 illus. Circuit Analysis • Vacuum Tubes • Circuits: Detector • Amplifier • Tube Oscillator • Power Supply • Transmitting, Receiving • Etc.

ELEMENTS OF RADIO SERVICING. 375 pages, 375 illus. Multimeters • AC Power Supply • Speakers • Antennas • Auto Radios • Push-Pull Output Stage

BASIC TELEVISION. 592 pages, 415 illus. Scrambling • Synchronizing • Video Signal • Brightness Control • DC Reinsertion • Picture • FM Alignment • Picture Tubes • VIF and VIF transmission Reception

TELEVISION SERVICING. 429 pages, 388 illus. Antennas • Transmission Lines • Test-pattern and Picture Analysis • Localizing Reception Troubles • Interference Remedies • Deflection Circuits AND MUCH MORE!

FREE 10-DAY TRIAL COUPON

McGraw-Hill Book Co., Inc., Dept. RTN-1
327 West 41st St., New York 18, N. Y.

Send me for 10 day free examination the Radio and TV Servicing Library, 4 Vols. (Regular retail price is \$26.75; Special Course Price only \$21.95 in easy installments.) If not satisfied with Course, I will return it, pay nothing. Otherwise, I'll send \$1.95 plus delivery then and only \$4.00 in monthly installments. If you wish to examine any of these books individually, check below the ones you wish us to send you for 10 Days' FREE EXAMINATION:

- | | |
|--|--|
| <input type="checkbox"/> Essentials of Radio, \$7.50 | <input type="checkbox"/> Elements of Radio Servicing, \$5.25 |
| <input type="checkbox"/> Basic Television, \$7.50 | <input type="checkbox"/> Television Servicing, \$6.50 |

For any book I keep, I'll send \$2.00 plus delivery in 10 days, balance in easy monthly installments.

Name

Address

City

Position

Company

WE PAY FOR DELIVERY if you send first payment of \$1.95 when ordering Library or full price when ordering individual books (prices above). Same return privilege. (Offer applies to U.S.A. only.)

distributors or manufacturers, but to broaden the experience of the members by pooling their practical knowledge.

In today's market when any group of service businessmen get together, the subject of operating costs comes up naturally since it is a never-ending problem in any business. As a direct result of such discussions, the activity of servicing as a business takes on a healthier tone in areas where service business associations have been formed.

Very few of these informal associations publicize their meetings or their activities. They look upon their cooperative efforts as something that is helping each member individually through their mutual understanding of their common problems and in that way the purpose of the association is fulfilled.

The trend in service business associations had a parallel back in the late twenties when the original Radio Technicians Guild was formed in New England by a handful of radio technicians who sought to pool their experiences in the servicing of AM receivers. As the membership of the original RTG grew they acquired a meeting place that could seat twenty-nine people. So they limited the membership to twenty-nine.

In his capacity as president of the original RTG, Al Saunders, who fathered the guild idea, assumed the responsibility of setting up a regular technical training program for Guild members which captured the attention of service people in many New England cities. This resulted in the formation of many Guilds organized expressly for the pooling of technical experience.

Many associations have, of course, developed into strong trade associations which exert a powerful influence on service activities in the areas where they operate. Perhaps the oldest, continuously successful service business association in the industry is the Associated Radio-Television Service Dealers of Columbus, Ohio. The success of this association stems from the self-help programs they have carried out consistently ever since the group was organized.

Basically a business organization, ARTSD holds a regular monthly business meeting without fail. Members who miss a certain number of business meetings consecutively are automatically dropped from the Association. Once dropped they must apply for reinstatement to participate in the Association's activities. The technical aspects of the business of servicing are covered in their quarterly technical meetings. These are carefully planned, skillfully executed clinics covering subjects that are of immediate, practical interest to service people in the central Ohio area.

A monthly bulletin called the "ARTSD News" keeps members apprised of association activities and carries terse, concise comments on in-

INTERNATIONAL RECTIFIER CORPORATION
EL SEGUNDO CALIFORNIA

DIRECT REPLACEMENT

RADIO & TV Selenium Rectifiers

UNIVERSAL MOUNTING

WIDER RANGE

NOW AVAILABLE AT YOUR FAVORITE JOBBER

Write for Bulletin JRP-1

INTERNATIONAL RECTIFIER CORPORATION

1521 E. Grand Ave., El Segundo, Calif. - Phone: DRegon 8-6281
CHICAGO, 705 W. Wacker Drive - Phone: Franklin 2-3889
NEW YORK, 507 Madison Avenue - Phone: Plaza 5-8665

dustry developments that are important to ARTSD members. Association officers who would like to see a copy of an effective one-page monthly association house organ can request a copy from John Graham, Editor "ARTSD News," 2552 North High Street, Columbus, Ohio.

A younger service business association that has climbed rapidly to national prominence as an effective trade association is the Television Service Association of Detroit, Michigan.

TSA of Michigan came into existence when the leading independent service companies of Detroit got together to find some way of bringing order out of chaos in TV service in the Detroit area after the initial TV service boom leveled off. Anyone who attends one of the regular monthly dinner business meetings of TSA in Michigan is deeply impressed with the high caliber of the men who operate TV service businesses in that area. These meetings are well organized. Talks given by business leaders are held strictly to a pre-planned time schedule and committee reports are terse, concise, and strictly to the point.

Under the capable guidance of Harold Chase, president of TSA, their monthly house organ has become a very substantial and widely read association business paper. In addition to the eight pages normally devoted to news of interest to TSA members, the "TSA News" carries a consumer section which is available in quantity to association members for mailings and give-away to their customers.

Service association officers interested in organization house organs may get a copy of the next issue of "TSA News" by writing to Harold E. Chase, president, TSA of Michigan, 16311 Grand Ave., Detroit 27, Michigan.

On a national scale, the registrations at the annual National Alliance of Television and Electronic Service Associations convention in Chicago last fall clearly indicated that service leaders in at least three-fourths of the states are interested in an effective national association of independent service businessmen.

The present directorate of NATESA practically spans the country from the eastern to the western coasts. There are many indications that basically strong associations are starting to develop in southern states. The Television Installation and Service Association of Memphis, for example, was ably represented at the NATESA convention.

News of the developments in this national service association are reported monthly in the organization's house organ, the "NATESA Scope." A copy of this publication may be obtained by association officials by writing to Frank Moch, president, NATESA, 5908 South Troy Street, Chicago 27, Illinois.

Growing Importance of Service

During the coming year the forces that make up the independent service

January, 1954



FOLLOW ARROW FOR BIGGEST STOCK AT LOWEST PRICES

- RADAR—TRANSMITTERS
- RECEIVERS — TUBES — PARTS



COMPLETE UHF TRANSMITTER-RECEIVER

Sensational New Year buy!
Frequency range 415-420 MC. Receiver uses 13 tubes. 5 Stages of 30 MC. IF amplifier. With schematic. Less dynamotor and tubes. Excellent condition. Never before offered at this money-saving price! **\$5.95**



C.A.P. SPECIAL BC-625 VHF TRANSMITTER

Freq. range 100-156 MC. With modulation section. Loss tubes & crystals, with conversion dope. Used, good condition. **\$9.95**

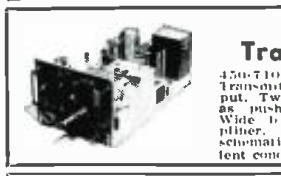

UHF Transmitter

430-710 MC. Tunable Transmitter. 10 W. output. Two 368-type tubes as push-pull oscillators. Wide band video amplifier. Loss tubes, with schematic. Excellent condition. **\$8.95**

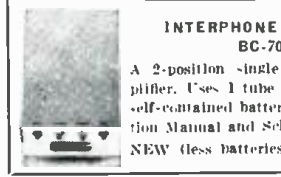

INTERPHONE AMPLIFIER BC-709-B

A 2-position single stage audio amplifier. Uses 1 tube and operates from self-contained batteries. With Instruction Manual and Schematic. **\$3.95**
NEW (less Batteries).....

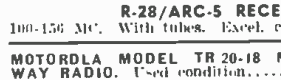

R-28/ARC-5 RECEIVER

100-156 MC. With tubes. Excel. cond. **\$45.00**

MOTOROLA MODEL TR 20-18 MOBILE 2-WAY RADIO. Used condition. **\$150.00**

RADAR TEST EQUIPMENT
TS-5, TS-12, TS-15, TS-33, TS-34, TS-35, TS-36, TS-45A/MS.

COMMAND EQUIPMENT (SCR-274N)		Used	New
BC-442 ANTENNA RELAY. Less cond.	\$1.95	\$ 3.95	
BC-451 TRANSMITTER CONTROL BOX WITH COND.		1.50	
BC-450 3-RECEIVER REMOTE CONTROL BOX		2.95	
MC-215 MECHANICAL DRIVE SHAFT. Per length		2.95	
BC-496 2-POSITION RECEIVER CONTROL BOX		2.95	
BC-454 RECEIVER. 4-6 MC. With tubes	12.95		
BC-455 6-9 MC RECEIVER. With tubes	9.95	14.95	
BC-457 TRANSMITTER. 4-5.3 MC. With tubes		9.95	
BC-458 TRANSMITTER. 5.3-7 MC. With tubes		\$9.95	\$0.95
MC-211 90° ANGLE COUPLING UNIT.			3.50
FT-234 MOUNTING RACK for single transmitter		2.95	3.50
FT-226 MOUNTING RACK for 2 Command Xmitrs.			3.95
FT-221 MOUNTING PLATE for FT-220			1.50
FT-220 MOUNTING RACK for 3 receivers		2.25	3.95
FT-225 MOUNTING PLATE for BC-456			2.25
BC-456 MODULATOR. For SCR-274.		5.75	1.25

Miscellaneous Specials!	
H-16U HEADSET. 8,000 ohms	\$3.95
HS-18 HEADSET. New	2.45
HS-23 HEADSET. High imp. New	4.95
HS-30 HEADSET. Featherweight type. Low imp. New	\$2.49 USED 1.49
HS-33 HEADSET. Low imp. New	6.95
HS-38 HEADSET. USED, excel. cond. New	1.49 3.50
T-32 DESK STAND MIKE. New	4.95
T-48 DESK STAND MIKE. New	4.95
LIP MIKE. Navy type. New	.98
MP-22 MOBILE ANTENNA. MOUNTING RACK. Comp. with hardware. Per Pair \$4.95.	2.95
TU-17 TUNING UNIT. (2-3 MC.) For BC-223 Xmitr. Used	2.95
TU-25 TUNING UNIT. (9.5-5.2 MC.) For BC-223 Xmitr. Used	2.95
I-70 "S" TUNING MEYER. NEW	2.50
WOBLATOR. See p. 43 Dec. '51 RADIO NEWS	5.95
BC-1023 75 MC. MARKER BEACON RECEIVER. Complete with tubes, mtg. rack. NEW	10.95

CCT-52232 NAVY COMMAND TRANSMITTER 2.1-3 MC. New, with tubes. \$14.95
250 TL TUBE.....Ea. \$9.95 Per Pair \$17.00

\$5.00 MINIMUM ORDER ACCEPTED. All items subject to Drop sale. All shipments F.O.B. warehouse. Calif. residents add tax with remittance. 20% deposit required. Please specify shipping instructions with order. EQUIPMENT WANTED! Highest prices paid for all types of Electronic Gear!

SCR-283 TRANSMITTER-RECEIVER. Complete with dynamotor and tubes. 40, 80 meter. F.B. for mobile. NEW with service manual. **\$24.50**



R.F. Modulator

Complete Tunable 205 MC. Test Set. With 110 V. 60 cps. power supply. 3-stage audio amplifier. Terrific chassis for experimentation. With schematic. Excellent. Like new. **\$9.95**

Monthly Specials!

ID6/APN4

Made to operate in conjunction with Radio Receiver R 91 V/APN-4. Unit includes 19 tubes, one 5" scope tube, crystal controlled standard oscillator, sweep circuits, marker pulses. Excellent cond. **\$42.50**

Also available: ID6A, ID6B. Write for quotations.

BC-604 30 W. FM TRANSMITTER. For 20-27 MC. band. Ideal for 10-11 meters. Complete with tubes, temperature controlled crystals, over and technical manual with all instructions for BC-603 and BC-601. Less dynamotor and crystals. Excel. cond. **\$12.95**

DYNAMOTOR SPECIAL: 9 V. Input. Output 450 V. 75 mts. With extended shaft and drive gear on one end. New. **\$7.95**
TA-12 TRANSMITTER. 50 W. Excellent cond. **\$29.95**
MP-28 POWER SUPPLY. Excellent cond. **\$14.95**

Miscellaneous Specials!

HAVE YOU ANY NEW OR USED RADIO GEAR TO SELL? FOLLOW ARROW FOR TOP PRICES!	
PE-125 POWER SUPPLY: Operates on 12 or 24 v. battery. NEW	\$17.95
CD-207 EXTENSION CORD. For 118-23-31. NEW	.95
RS-38 MIKE. Excellent cond.	3.95
SCR-625 MINE DETECTOR. New	\$9.50
T-9 MODULATION TRANSFORMER. For BC-610 transmitter. New	\$4.50
TELEPHONE REPEATER AMPLIFIERS:	
EE-90. New, with tubes	17.95
EE-89. New	12.95
FL-8 RANGE FILTER	1.95
PL-68 MIKE PLUG. New	.79
UN-4 L R TUNING METER. New	5.99
FL-55 HEADSET PLUG. New	3.95
FL-5 RANGE FILTER	.95
TS-10 SOUND POWERED HAND SET—Used, excel. cond. Per Pair	14.50
PE-55 DYNAMOTOR 12 V input. 500 VDC @ 200 mls output. New	24.50
FIELD TELEPHONE. EP-R. Complete. BRAND NEW. SPECIAL UNLS	27.50
DC OVERLOAD RELAY. West. 0.2-1.0 amps.	6.50
234-258 MC RECEIVER	17.95

INDUSTRIAL CORPORATIONS

We carry one of the most complete stocks in U. S. of Military Electronic Equipment, Test Equipment, and Aircraft Electronics. Call or write for our catalogue.

All shipments F.O.B. warehouse. Calif. residents add tax with remittance. 20% deposit required. Please specify shipping instructions with order. EQUIPMENT WANTED! Highest prices paid for all types of Electronic Gear!

ARROW SALES, INC.

Cable Address: ARROWSALES POplar 5-1818

Mailing Address: P. O. Box 3878-R, N. Hollywood, Calif.
Office-Warehouse: 7460 Varma Ave., N. Hollywood, Calif.

Concertone

"Just like being there"

THE ONLY TAPE RECORDER UNDER \$1000 WITH ALL THESE FEATURES

- Designed for Custom, Console, or Portable installation ★
- 50-15,000 CPS frequency response with negligible distortion ★
- 3 Heads — Monitor from the tape while recording ★
- 3 Motors for superb tape motion and fast forward and rewind operation ★
- Instantaneous selection of 7 1/2 or 15 ips with automatic equalization ★
- "Straight line" tape threading ★
- Plays up to 10 1/2 inch reels without extension arms ★
- Interchangeable heads for single or dual track ★



MODEL 1501

Professional Users
Net \$345.00

WRITE FOR BULLETIN 201



4917 W. Jefferson Boulevard Los Angeles 16, California



ARGYLE

again revolutionizes
TV installation
business... one look
shows you
how

The Argyle Mast Type Universal Standoff combined with the new Argyle Mast-Lok clamp permits the best installation possible. Is stronger, more versatile—clamps will not slip or loosen... entire installation is done in a few seconds.



a must
for UHF...
you need it
for VHF too!

1 PAT. APPLIED FOR

Now — Argyle introduces Mast-Lok... the clamp used in conjunction with the Universal Mast Type Standoff! Available at no difference in price.

The strongest, quickest, and most positive method of securing standoffs to the mast... heavy duty steel with a re-inforced cantilever clamp.

- Improves Reception... rigid engineering and lab tests prove that the New Argyle Universal Standoff tends to substantially reduce coupled-in effects and related evils in the line.
- Big Time Saver... you can actually save 75% of your installation time.
- No Threading — use any type of wire at all... Flat, Tubular, Open, Rotor — When ordering MAST-LOK with Argyle Universal Standoffs* — add letters MC after model number of standoff... Separately model AMC-12.



ARGYLE ELECTRONICS CO.

8 West 18th Street, New York 11, N. Y. • CH 2-2093

industry will have a golden opportunity to establish the activity of electronic servicing as a sound business enterprise and as an element of the electronics industry equal in stature to that of manufacturing and distributing. It will be a critical year because the success or failure to accomplish the objective that will be economically obtainable will depend upon individual foresight shown in the action of the thousands of men who now operate service businesses of many sizes.

A credo that should be carefully studied by every man who operates a radio or TV service business is that expressed in a speech by Leonard R. Smith, president of the Texas Electronics Association, at that Association's convention last fall: "Our Industry is too big, too constructive, too rich in potential, too needed by the public for us to permit ugly, dirty little practices to thrive in it. Let's band together for a cause we know is right, and we will have the satisfying knowledge that we will have all right thinking people with us, working to make a tomorrow we can live in with satisfaction, dignity, and pride."

The fundamental objective of any trade association is to bring about stability in the business it serves and to improve the lot of its members. However, to accomplish these objectives it must have the active support through membership of the best elements in the scope of its activity, and those members must be willing to forego some of the practices that are usually pardoned under the guise of rugged individualism. This is the age of cooperation, and guided cooperation that is possible only through association activities can be accomplished only through representative membership in an organization dedicated to improving the status of the industry.

One of the most interesting news studies that has come to the attention of your editors recently is one which told of the clinics planned by the National Electronic Distributors Association to discourage the indiscriminate sale of electronic parts, tubes, accessories, and supplies at wholesale prices. Many parts distributors sell only to classified accounts at wholesale prices, but the action of NEDA indicates a new trend.

The need for raising the standards of business thinking at all levels of the TV industry was forcefully underlined in a recent speech by Paul H. Leslie, G-E television sales manager:

"I know of no other business," he said, "in which an entire industry seems so completely dedicated to the practice of selling the lowest quality merchandise at the lowest possible prices and at the lowest profit to all concerned."

He urged dealers to "take a leaf from the book of other successful consumer goods industries which have realized that volume can no longer be obtained by producing lower quality goods at reduced prices."

—50—

RADIO & TELEVISION NEWS

New

RADIO COURSE only \$2.50



MADE MONEY 1st WEEK
"You should get more money for your Course. The first week I studied it, I made \$10.00 repairing sets. I built my own test outfit from details given in this course. I have repaired 100 radios to date."

Signed: *Robert C. Hammel*,
120 W. 13th, Davenport, Iowa.



COMPLETED IN 8 WEEKS
"I am very satisfied with the course. When I was at the twelfth lesson I started repairing radios. It took me two months to master your course." From a letter written by *Roger Langlois*, 1679 Poupard St., Montreal, Canada.



MODERN, UP-TO-DATE
"Your course is modern and up-to-date. There is not one page in the whole course which anyone can afford to miss. Your course started me on the road to a well paid job and has repaid me many times." *Charles Alspach*,
433 Elm St., Reading, Pa.

AMAZING BARGAIN OFFER

Here is a practical home-study course that will teach you how to repair all radio sets faster and better. These newly reprinted 22 lessons cover all topics just like other correspondence courses selling for over \$150.00. Our amazing offer permits you to obtain the course complete for only \$2.50, nothing else to pay. Easy-to-follow, well illustrated sections on test equipment, circuits, auto sets, alignment, F.M., use of oscilloscope, amplifiers, and every other topic needed to be an expert in radio repairing. Trouble-shooting hints, circuits, short cuts, service suggestions, new developments. Send coupon today, and use the complete course at our risk. Satisfaction guaranteed. All 22 lessons, in large manual form, + self-testing questions, **\$2.50** complete, your cost only.....

INTRODUCTION TO TELEVISION

These 22 practical lessons making up this course-book are easy to follow and apply to actual radio jobs. Use this training to get ahead in radio and as an introduction to television. Radio facts that puzzled you will be quickly cleared up. You will find yourself doing radio repairs in minutes instead of hours — instantly finding faults or making needed adjustments. Every new radio development of importance and thousands of time-saving radio facts are packed into this complete course-manual. For example, there is a large lesson on servicing F.M. sets and another full lesson on audio amplifiers. Use coupon below to order course for 10-day examination in your own home. Look over the material, read a few lessons, apply some of the hints. Then decide to keep the lessons at the bargain price of \$2.50 (full price), or return the material and get a cash refund.



Supreme Radio & TV Manuals

Your complete source of all needed RADIO and TV diagrams and service data. Most amazing values. Still sold at pre-Korean prices. Only \$2 to \$3 per volume. Every Radio manual contains large schematics, all needed alignment facts, parts lists, voltage values, trimmers, dial stringing, and service hints. Each TV manual is a practical treatise on servicing the year's sets, with giant blueprints, patterns, waveforms, hints, charts, suggested changes. See coupon at right for a complete list of these low-priced manuals.

Supreme Publications

Sold by All Leading Parts Jobbers

NO-RISK TRIAL ORDER COUPON

SUPREME PUBLICATIONS, 1760 Balsam Rd., Highland Park, ILL.

- Radio Diagram Manuals
- New 1953 Manual, \$2.50
 - 1952 Radio
 - 1951 Diagrams } \$2.50
 - 1950 Manual } EACH
 - 1949 Radio
 - 1948
 - 1947
 - 1946
 - 1942
 - 1941
 - 1940
 - 1939
 - 1926-1938 Manual, \$2.50
- RADIO MANUALS
PRICED AT ONLY
\$2
EACH

- Send Radio and TV manuals checked at left and below. Satisfaction guaranteed or money back.
- Complete RADIO COURSE, all 22 lessons...\$2.50
 - 1953 TV Manual, \$3. 1953 UHF Units, \$1.50
 - 1952 Television Manual, \$3. 1951 TV, \$3.
 - 1950 Television Manual, \$3. 1949 TV, \$3.
 - 1948 TV, \$3. 1947 TV & FM, only \$2.
- I am enclosing \$..... Send postpaid.
 Send C.O.D. I am enclosing \$....deposit.

Name:
Address:

ORDER BY MAIL FROM WHOLESALE RADIO PARTS CO., INC.

Equal to \$50 Aerial Systems All Directional TV AERIAL 360° DIRECTRONIC SYSTEM

Exclusive Snyder Engineering and designs cut cost to **\$18.95**

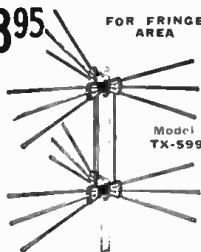

COMPLETE with three 31 1/2 ft. masts, 75 ft. 3 cond. cable, Beam selector sw., guy rings and mts. base. Electronically beams complete "AUTO" rotation to give clear pic on all channels. You choose direction with directronic selector sw. mounted on or near TV set. Complete double stacked array with 18 hi-tensil double alloy aluminum elements. AX-599 same as TX-599 less masts, guy rings & mtg. base.....\$18.95

ALL CHANNEL UHF BOW TIE & REFLECTOR



Channels 14-83

All pre-assembled. Just unfold, tighten and erect. Hi-tensil aluminum low. All-welded steel screen. All-weather zinc-plated. U clamp included. Model UHF-5 **\$1.49**
UHF-6 BOW TIE with Corner Reflector... **\$3.49**

General Electric and Westinghouse Tubes

OZ4	.83	6BE6	1.03	12AT7	1.43
1A7GT	1.33	6BG6	2.60	12AU7	1.20
1S3GT	1.33	6BK7A	1.50	12AK7	1.28
1R5	1.18	6BL7GT	1.60	12BE6	1.03
1X2A	1.30	6BQ6GT	1.90	12BH7	1.38
1Q5GT	1.40	6C4	.60	12BY7	1.35
5U4G	.88	6CD6G	2.40	12SA7	1.03
5V4G	1.33	6F6GT	1.00	12SK7	.95
5Y3GT	.68	6I6	1.25	12SN7GT	1.18
6AB4	.90	6K6GT	.90	12SQ7	.85
6AC5	1.10	6L6	1.60	25W4GT	1.03
6AK5	2.18	6SN7GTA	1.18	25Z6GT	.98
6AL5	.88	6V6GT	1.00	35W4	.68
6AU6GT	1.60	6WA2T	.95	35Z6GT	.70
6AU6	.93	6WG6T	1.20	50R5	1.03
6AV5G	1.60	6XSGT	.78	50L6GT	.95
6BC5	1.00	7I7	1.18	117Z3	.90

600V Molded Plastic Tubular Condensers

.0005	.10	.02	.12
.001	.10	.025	.12
.002	.10	.03	.15
.003	.10	.035	.15
.004	.10	.04	.15
.005	.10	.047	.15
.006	.10	.05	.15
.007	.10	.055	.15
.008	.10	.06	.15
.009	.10	.068	.15
.01	.10	.075	.15
.012	.10	.08	.15

HOT SPECIALS FROM OUR BARGAIN COUNTER

- WESTINGHOUSE Type 5979 BS-1 Alpha, Beta, Gamma, Counter tube \$ 8.95
- WESTINGHOUSE Type 5980 852 Gamma Counter tube..... 2.49
- Pix tube - brightener for parallel circuits. Part No. A-4 4.95
- SPECIAL Brush Model BA-116 crystal microphone 1.49
- 4" Sq. Alnico V PM Speaker..... 1.19
- 5" Sq. Alnico V PM Speaker..... 1.29
- 12" Round Alnico V PM Speaker..... 4.95
- 12" 14.2 mfd. 50 ohm Dynamic Speaker..... 3.95
- 110 V AC Motor 3 1/2"x2"11 1/2" 2800 rpm at full load..... 1.69
- TV Chatter Cord, Stand, type, 6 ft. U.L. approved TV Chatter Cord, Philco, Zenith type, 6 ft. U.L. approved..... .29
- 1/2" anode connector with 1 1/2" lead for TV Pix tube 20-20 mfd.-150 volt, Gudeman tubular electrolytic, condenser..... .29
- 16 mfd.-450 volt, Gudeman tubular electrolytic, condenser..... .29
- PHONE PLUG, standard type..... .29
- Carbonfilm 2 meg, 2 watt, +/-1% tolerance..... .49
- 100 assorted 1/2-1 1/2 watt carbon resistors..... 1.95
- 100 assorted 5 mfd. to .001 mfd. mica condensers..... 1.95
- 100 assorted (18 values) 1/2 watt resistors in partitioned plastic box..... 4.95
- Phono pickup arm with crystal cartridge (78 rpm) 3 speed phono motor with 8" turntable..... 5.95
- Willard type N-T-6 midget 6 volt storage battery (less acid)..... 2.49
- Volume controls, with switch (2" shaft). Choice 1/2, 3/4, or 1 meg. Each..... .49
- 100 ma. selenium rectifier 1 1/2" 3/4" sq. plates..... .85
- 250 ma. selenium rectifier 1 1/2" 3/4" sq. plates..... 1.35
- 400 ma. selenium rectifier, 1 3/4" sq. plates..... 1.95
- Audio amplifier-5 watt, 3 tube AC amp..... 14.95
- Army surplus headphones Type HS-16A, 125 ohm DC resistance..... 1.95
- Signal Corps Hand Key Type J-38..... 1.49
- Mechanical reproducer head..... .95
- 3 speed, single needle, manual port. phonograph..... 16.95
- 2 volt storage battery (surplus) Willard 20-2..... 2.95
- 2 volt vibrator, round can, 7 prong. Surplus..... 1.95
- Type VB-8..... 1.95
- 18" extension for auto antenna lead-in..... 1.95
- Type LLA..... 1.95
- Crystal phono cartridge (78 rpm) 3 volt output..... 1.49
- Vertical Output Transformer, Turns ratio 10:1, mfg. centers 2 1/2 1/2", Part #43T011. Replaces Stancor A-8112 and Merit A-3036..... 1.79
- Vert. Block Osc. Transf. (shaded) Turns ratio 14:2, mfg. centers 1 1/2 1/2". Part #16TV11. Replaces Stancor A-8121 and RCA 208T2..... 1.49

FREE! Write for big new FYI Bulletin #126

STANDARD COIL'S REPLACEMENT CASCODE TV TUNER

Lowest Price For Series TV-2000
Has tube complement of 840 osc and conv. and a 6BQ7 or 6BZ7 as RF amp. Designed for inter-carrier circuit and also adaptable for split sound IF circuits such as the "630" and similar types. By use of unit #AM752 trap assembly (available separately) IF is adj. 19 to 26 mc. Adaptable to UHF. Shaft length 4 1/2" overall. **\$1.14**
UHF STRIPS. Available for Standard Coil tuners. Specialty channel no. and series designated by letter such as F, G, Q, etc. stamped on each strip of your present tuner. Set (osc. & ant)..... **\$7.50**

TV TUNER FOR OLDER SETS
Series TV-2000. Standard coil's original type tuner. Has sound trap which can be eliminated for use in intercarrier circuits. Sound IF of 21.25 mc. Shaft length 3" overall. Pre-aligned. **\$16.95**

PRECISE MARKER GENERATOR KIT

FOR RF-AF-TV
Fundamentals thru 110-300 MC on harmonics. Audio 20 to 20,000 cps. Cathode follower output; variable per cent modulation. Stepping attenuator. External modulation speech amplifier. Crystal marker.
Model..... **\$33.95**
630K Kit with preassembled RF head..... **\$38.95**
630W Factory wired..... **\$53.95**

- 300K 7" SCOPE KIT..... \$94.50
- 300K 8 1/2" SCOPE KIT..... \$129.50
- 635K UNIVERSAL AF SINE, SQUARE & PULSE GENERATOR KIT..... 33.50
- (0.1% wired)..... 52.50
- 610K RF SIGNAL GENERATOR KIT..... 23.95
- (0.1% K..... 28.95
- (0.1% wired)..... 39.95
- 907K VTRM KIT with 7 1/2" METER..... 38.98
- (0.07% wired)..... 57.98

- ### G.E. GLOBAL RESISTORS
- RRW-041 7 1/2 ohms..... .90
 - 10 watt..... .99
 - RRW-051 20 ohms..... 1.05
 - RRW-052 100 ohms..... .90
 - RRW-054 25 ohms..... .90
 - 0.6 amps 1.05
 - RRW-061 15,000 ohms..... .90
 - RRW-072 15,000 ohms..... 1.05
 - RRW-088 11,000 ohms..... .90
 - RRW-094 31 ohms..... 1.14

NEW! UNIVERSAL Adjustable SINGLE ION TRAP
Type 6295. Adj. from 32 to 45 gauss.
60c

WHOLESALE RADIO PARTS CO., Inc.

311 W. BALTIMORE ST., BALTIMORE 1, MD.



NEW! THE ONLY COMPLETE BOOK ON TELECASTING!
covers every phase

"Principles & Practices of TELECASTING OPERATIONS"

by HAROLD E. ENNES



600 PAGES OF PRACTICAL INFORMATION for everyone interested in TELECASTING

Indispensable to the Engineer, Production Man, Director, Technician, and to all Students of the Video-Audio Art

top reference on Telecasting

CONTENTS:

A Partial List of Authoritative Chapters:
Basic Telecasting Equipment; The TV Camera; The TV Control Room; Fundamentals of TV Studio Lighting and Equipment; Network Program Relay Systems; TV Operational and Maintenance Practices; Technical Production of TV Shows; Field Equipment and Microwave Relays; Analysis of Video and Audio Transmitting Plants; Technical Definitions — PLUS HUNDREDS OF OTHER SUBJECTS

Here, in one complete, easy-to-understand volume is the whole fascinating story of Telecasting operations. Whether you are a Chief Engineer, Production Director or Technical Director; if you are now working in or planning to work in TV, or if you are simply interested in Telecasting, this book is *meant* for you. Here is practical, useful information that makes you familiar with the equipment and techniques used in Telecasting, tells you *everything*—answers all your questions about TV production and transmission. If you work or are interested in Telecasting, you'll want this vast wealth of reliable information—you'll want this book in your library. Order your copy today!

600 Pages, 450 Illustrations
6" x 9"
Hard Covers **\$7.95**

ORDER TODAY!

Order from your electronic parts distributor or bookstore, or write direct to Howard W. Sams & Co., Inc. 2203 E. 46th St., Indianapolis 5, Ind.

My (check) (money order) for \$..... enclosed. Send the following:.....copy(ies) of "Telecasting Operations" (\$7.95 per copy).

Name.....

Address.....

City.....State.....

Convair Computer
(Continued from page 61)

the arm of a potentiometer can multiply or divide. (e) For trigonometric functions, the amplifier (Fig. 2G) controls a servo-driven sine-cosine potentiometer.

In each case, the amplifier is the heart of the computing element. Other devices such as function generators for non-linear equations, limiters, relay amplifiers, and recorders are used where required for a solution. The computer at Convair has many combinations of these devices.

Now the visitor remarks, "These gadgets are all very fine. Let's see you solve a problem with them."

That seems like a logical request so let us run through a simple problem to see how the computer works.

Take a classical example, the spring supporting a weight. Fig. 2II. This problem requires some set-up work before the computer can be of use. First we must find an equation describing the problem. x_1 is the position of W hanging on the spring, k . x_2 is the condition when W is displaced by some force pulling the weight down. The equation expressing this system is $m(d^2x/dt^2) = -kx$ where x is the displacement of the weight from its rest position x_1 .

In order to set up the computer, the equation is rearranged to read: $(d^2x/dt^2) = -(k/m)(x)$. The desired answers to this equation are the displacement, velocity, and acceleration of the weight, W , at any time after the weight is released. The computing elements (Fig 2I) needed for a solution are: two integrating amplifiers (1), a potentiometer set at the ratio k/m (2), and an inverting amplifier to change the algebraic sign (3).

Now we are ready to patch up the problem on the computer patchboard, Fig. 2J. Assume, to start, that you have a voltage equal to d^2x/dt^2 on one end of a patch cord. This is plugged to the input of Integrator 1. The output of this integrator will be $-dx/dt$. This value is patched to Integrator 2 whose output will be x . Going back to the equation, we note that $d^2x/dt^2 = (k/m)(x)$ so we patch the output of Integrator 2 to a potentiometer set at the ratio of k/m . We still have to change the sign so the potentiometer is then patched to the input of an inverting amplifier which changes the sign. At the output of the inverter appears $-(k/m)(x)$, which is equal to d^2x/dt^2 which is the value we assumed to be the input to Integrator 1 in the first place. So, we patch the output of the inverter to this point.

We now have taken care of everything but setting the system into operation. This requires that we duplicate in the computer the initial conditions, i.e., the weight is motionless because it has not been set into motion by releasing the force holding the weight in the position where the

REAL SAVINGS!
AT PART-MART

MOTORIZED!

NEW 1/18 HP Universal Motor. Perfect for small blowers; small dental or jewelers' lathes... for shop or lab work. 115 Volts, A.C. DC, 25 to 60 C. Rated speed 9000 RPM; Free speed 13,000 RPM. 1/2" shaft. Mtg. holes 1 1/4" C. to C. Flat sides. Rugged construction. Die-cast end bells. SHIPPING WT. 3 LBS. STOCK NO. W109.



\$4.75
EACH

MALLORY INDUCTUNER

Way below wholesale cost for this popular 3-gang tuning device! Use as replacement or in own designs for TV and FM receivers and boosters. Continuous tuning from 52-120 mc and 175-216mc with 4 turns of shaft. Size, 4 1/16" x 2 1/8". Shaft length, 3". SHIPPING WT. 3 LBS. STK. NO. L108.



\$2.19
EACH

\$2.49 EACH

LOTS OF 3

"UNIVERSAL" FLYBACK



Perfect for general replacement and conversion use. The *really flexible* universal mtg. bracket fits most sets. 7 secondary taps to match all usual yoke inductances, from 7.5 to 30 mh. Primary taps to match all output tubes and "B" supplies from 240-360 V. For 50-70 deflection. Maximum high voltage up to 16 KV.

SHIPPING WT. 2 LBS. STOCK NO. S110.

\$4.65

EACH LOTS OF 3

\$4.95
EACH

ADJUSTABLE ION TRAP



Newest Beam Bender with adjustable feature which allows magnetic field to be varied between 32-55 gauss. Will replace old style ion traps having specific magnetic fields. One universal ion trap to take care of all your needs!

SHIPPING WT. 8 OZS. NO. S111.

3 FOR \$1

38c EACH

TV TUBE "BRITENER"

Extend life of Picture tube with this newly designed rejuvenator! Increase cathode emission and improve brightness-contrast. Fits all makes of TV tubes. Takes one minute to plug into any set having parallel-wired filaments. No tools or soldering required. Fully automatic. SHPG. WT. 1 LB. NO. S112.



\$1.35

EACH LOTS OF 3

\$1.25 EA.

LINE VOLTAGE TESTER

NEW! Just what you need! An inexpensive, accurate line voltage tester that will give you instantaneous readings right at the receptacle. NO WIRES—NO ASSEMBLY... JUST PLUG IN! Swivel head for easy reading. AC only. Reads 0-150 Volts ± 5%. Precision-made. Steel case.



SHIPPING WT. 1 LB.

STOCK NO. S113 **ONLY \$3.00 EA.**

FP CONDENSER KIT

TEN (10) popular multiple section, FP Electrolytics. Twist-prong mtgs. Capacities up to 50 mfd. Voltages from 25 to 450 Volts. These are quality products of the industry's Leaders! Fresh stock. Sh. Wt. 3 lbs.



NO. L103.

KIT OF 10

\$2.49 EACH

\$2.29 EA. KIT—LOTS OF 3

Write for Additional Listings
INCLUDE POSTAGE—EXCESS PROMPTLY RETURNED
TERMS: F.O.B., N. Y. C.—MIN. ORDER \$3.00—25% Deposit on C.O.D. Orders. SAVE C.O.D. CHARGES—REMIT IN FULL PLUS POSTAGE. Excess Promptly Returned. SUBJECT PRIOR SALE.

PART-MART
ROCKVILLE CENTER L. I., N. Y.

displacement is $-x$ (the sign is negative because the force is in a downward direction). To put this initial condition into the computer, a charge corresponding to the initial output voltage, $-x$, must be placed on the feedback condenser of Integrator 2. There is no initial condition required at Integrator 1 because the output of Integrator 1, which is the velocity, dx/dt , at the start of the problem, is zero.

The control switch of the computer, which is in the "Reset" position, is thrown to "Operate" which is analogous to releasing the weight. The output voltage of Integrator 2 will rise and fall just as the weight rises and falls.

These three answers can be obtained on a recorder or other measuring device: The displacement of the weight, x ; the velocity of the weight, dx/dt ; and the acceleration d^2x/dt^2 . Fig. 2J.

This problem is a very simple one to solve either by "longhand" or with the computer. The value of the computer can be appreciated if any of the parameters of the system are varied. The answers appear instantly. Thus, it is possible to run a system from "one end to the other" and be able to determine its capabilities at once.

Because of the comparatively lengthy set-up time on the patchboards, the *Convair* computer has removable patchboards. This allows the operating station to be occupied only during actual computation. While one operator is setting up a problem, another can be using the machine. Fig. 1 shows the removable patchboard with a problem patched in. It also shows portions of two operating stations. At either side are the controls for each station. Answers may be read on the eight-channel recorders in front as well as on the meter on the control panel. Trunk lines between stations allow operators to "borrow" equipment appearing on adjacent patchboards.

The million-dollar computer is housed in a temperature- and humidity-controlled area to insure minimum variations caused by temperature fluctuations or leakage due to atmospheric moisture. Many factors were considered in the design and layout of the computer: (1) High stability over long periods of time, (2) Isolation of critical elements, (3) Modern, neat appearance, (4) Ease of operation and maintenance.

Needless to say, many problems had to be met and overcome in the design and construction of the *Convair* computer facility. As various portions are placed into service, new problems arise that require solutions and new techniques are developed. With the completion of the computer facility, *Convair* will have a versatile, accurate, time-saving device that is rapidly becoming an indispensable tool in the art of aircraft design and manufacture.

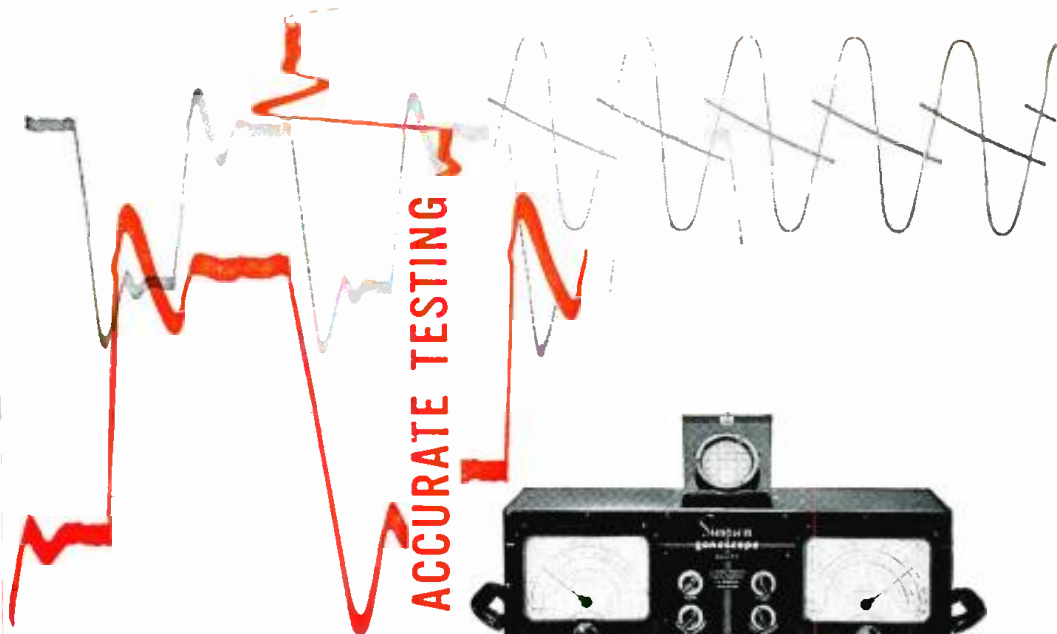

approved by
service managers of:

admiral
zenith
motorola
emerson
hoffman
hallicrafters

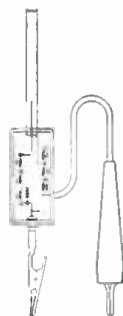

- All the necessary signal sources for alignment of FM and TV receivers • Includes the Simpson High Sensitivity Oscilloscope and high frequency crystal probe for signal tracing • Independent, continuously variable attenuators and step attenuators for both AM and FM units offer complete control of output at all times • 0.15 megacycle sweep is provided by a noiseless specially designed sweep motor based on D'Arsonval meter movement principles • The exclusive Simpson output cable (illustrated) includes a variable termination network, quickly adapted to provide open, 75 or 300 ohm terminations — the addition of a pad provides attenuation and isolation • Use of appropriate resistors across certain terminals will provide any other termination required. A .002 MFD blocking condenser can be added on any termination for use on circuits containing a DC component • The FM generator output voltage is constant within .2 DB per MC of sweep.

dealer's net \$475.00

SIMPSON ELECTRIC COMPANY

5200 W. Kinzie St., Chicago 44, Illinois • Phone ESTebrook 9-1121 • In Canada: Bach-Simpson, Ltd., London, Ont.

TUBES

RCA, G. E., SYLVANIA
AT TREMENDOUS SAVINGS OVER
REGULAR WHOLESALE

OTHER TUBES AVAILABLE AT SAME LOW, LOW PRICES

Latest Code Dates • Boxed • Fully RTMA Guaranteed

0Z4	.62	6AK5	1.30	6BQ7	1.42	12AV7	.85
1B3	.95	6AL5	.63	6BZ7	1.52	12BA6	.73
1X2	1.06	6AQ5	.76	6CB6	.76	12BE6	.78
5U4	.43	6AU6	.67	6J6	.92	12SA7	.80
5Y3	.48	6AV6	.60	6K6	.65	12SK7	.77
6AB4	.80	6BA6	.71	6SN7	.85	12SQ7	.67
6AC7	1.25	6BG6	1.98	6V6GT	.75	35W4	.49
6AG5	.83	6BK7	1.28	6W4	.70	35Z5	.51
6AH6	1.40	6BQ6	1.42	12AT7	1.05	50L6	.75

Brand New Pix Tubes Full One Year Guarantee

	With Old Tube	With Old Tube
10BP4...	10.50	10.00
12LP4...	12.50	12.00
12LP4A...	14.50	12.00
16AP4...	19.00	16.00
16AP4A...	23.00	16.00
16DP4/A...	18.50	16.00
16GP4...	21.00	16.00
16RP4...	19.00	16.00
17BP4...	20.00	17.00
17CP4...	22.00	17.00
19AP4...	24.00	19.00
19AP4A...	25.00	19.00
20CP4...	26.50	20.00
21EP4...	29.50	21.00

STUART ELECTRONIC DISTRIBUTORS

149-09 Union Turnpike
Flushing 67, N. Y.

Dept.—R12

Minimum Order \$10.00

OLympia 8-3553, 4352

TERMS: 25% Check or Money Order, Balance C.O.D., F.O.B. New York. Satisfaction Guaranteed.

HARVEY



**AUTHORIZED
DISTRIBUTOR**

presents

2 NEW RCA PORTABLE SIGNAL GENERATORS

Especially suited to the requirements of the Service Technician, the Audio Experimenter, the Factory and the Laboratory.



RF SIGNAL GENERATOR

Model WR-49A — Has DC isolated, cathode-follower outputs so that signals can be injected into any point in the circuit. New dial design facilitates accurate readings. Thorough shielding minimizes radiation, and hum pickup. Other outstanding features include:

- Frequency Range: 85 kc to 30 mc.
- Calibration accuracy on all bands $\pm 1\%$.
- Built-in 400-cycle oscillator for internal modulation or external use.
- Modulation continuously variable up to 70%.
- Attenuator Range: 65 db.
- Weighs only 8 lbs.

Complete with tubes, shielded cable, and instructions **\$59.50**



AUDIO SIGNAL GENERATOR

Model WA-44A—Extremely valuable for measuring performance of amplifiers, tone controls, equalizers, loudspeakers, and other audio circuits and components. Has DC isolated cathode-follower outputs so that signals can be injected into any point without loading the circuit or reflecting any reactance. Other outstanding features include:

- Frequency Range: 11 cps to 100 kc.
- Response ± 1 db.
- Additional 60-cycle signal for Intermodulation Distortion tests.
- Regulated oscillator power supply.
- Weighs only 10 lbs.

Complete with tubes, shielded cable, and instructions **\$87.50**

NOTE: Prices Net F.O.B., N.Y.C. Subject to change without notice.

Harvey

RADIO COMPANY, INC.

103 W. 43rd St., N. Y. 36, N. Y. • JU 2-1500



WHAT'S

New in Radio

The products described in this column are for your convenience in keeping up-to-date on the new equipment being offered by manufacturers. For more complete information on any of these products, write direct to the company involved.

MINIATURE POTS

Waters Manufacturing, Inc., Waltham 54, Mass. is now in production on a new line of high-reliability, wire-wound miniature potentiometers which have been precision-built to military specifications.

The RT series have anodized-aluminum bodies with sealed, line-reamed shaft bushings and sealed terminals plates which enable these units to meet severe environmental tests.

They measure $\frac{7}{8}$ " in diameter and $\frac{3}{8}$ " in depth. Power dissipation is 3 watts at 80 degrees C. Rotational life is more than a million revolutions. Resistances available are 10 ohms to 50,000 ohms, linear taper.

NEW SWITCH LINE

Erie Resistor Corporation, Erie, Pa. has announced the availability of a new full line of rotary selector and

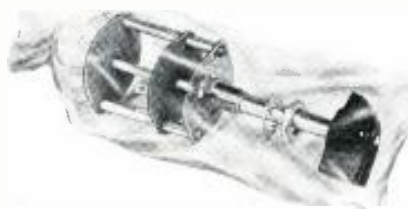

lever switches. Twenty-five item numbers are included in the four styles in single or multiple sections, shorting and non-shorting types.

Among the new design features are a "Wedglock" which fastens the contact to the stator and prevents loosening or rotating due to soldering heat, a rotor assembly combined with the solid stator providing a construction in which the rotor blades do not support the assembly, and the use of high grade phenolic sheet for insulation.

Descriptive literature is available from jobbers, distributors, or from the electronics distributor division of the company.

LOW-PASS FILTERS

Barker & Williamson, Inc., 237 Fairfield Ave., Upper Darby, Pa. is currently marketing two new low-pass filters which have been designed to help the radio amateur overcome TVI from his rig.

The wave-guide principle employed in the design of these units makes possible a unique type of mechanical construction which permits more sections to be built in less space. The result is a high order of attenuation—85 db through the TV band with more than 100 db on channel 2. With an attenuation of 85 db equivalent to a voltage

ratio of 17,780 to 1, this means that undesirable harmonics causing TVI will be reduced by the same ratio.

Both filters can handle more than 1 kw. of modulated r.f. power continuously. Insertion loss is less than .25 db through the entire passband to 30 mc.

The new filters, available in 52 ohm and 75 ohm impedance models, are fully described in a bulletin which is available from the company on request.

FILM-TYPE RESISTORS

International Resistance Company, 401 N. Broad St., Philadelphia 8, Pa. has recently put a new molded boron carbon resistor on the market.

The Type MBC, a $\frac{1}{2}$ w. unit, is molded in a special plastic housing to provide complete mechanical protection and features improved moisture, load life, and shelf life characteristics.

The size is equivalent to that of a 1 watt composition resistor and measures $\frac{1}{16}$ " long, $\frac{5}{32}$ " in diameter, $1\frac{1}{2}$ " lead length, and .32" minimum lead diameter.

For further information on this new resistor which is designed for applications where stability, accuracy, high-voltage insulation, and economy are requisite, write the company direct.

STABILIZED CRYSTAL

James Knights Company of Sandwich, Illinois has introduced a new stabilized crystal, the JK G-12, which has been designed to handle applications in the 500 kc. to 1500 kc. range.

The new unit provides stable frequency control for applications such as frequency standards, timing and counting circuits, broadcast equipment, and frequency monitors.

Electrodes are deposited directly on



the precision-made quartz plate, shock-mounted in an evacuated glass envelope. The crystal may be designed for a minimum temperature coefficient

RADIO & TELEVISION NEWS

from 0 to 50 degrees C or for temperature controlled operation at 60 degrees C.

The crystal is 2 3/4" in height above the chassis and the maximum diameter of the octal base is 1 3/4".

PRINTED CIRCUIT KITS

Centralab, 900 E. Keefe Ave., Milwaukee 1, Wisconsin is now furnishing its printed electronic circuits in four handy kit assortments.

The kits range from a group of 18 P.E.C. units to a complete stocking



cabinet of 220 plates. The kit assortments have been carefully assembled using actual sales figures so that the service engineer, industrial laboratory, components lab, or distributor will have the most popular circuit at hand.

Kit PCK-18 has 18 P.E.C. units in a plastic box. PCK-45 has 45 units in a plastic box. PCK-110 has 110 units in a metal cabinet, while PCK-220 offers a complete assortment of 220 units in a sturdy metal cabinet.

The company's distributors are handling this new item.

ANTENNA LOADING COIL

K-W Engineering Works, 3145-A North 48th Street, Milwaukee, Wisconsin is offering a new mobile antenna loading coil which provides the radio amateur, small boat owner, and other medium frequency service user with a dynamically efficient inductance for resonating the antenna.

In the "Dyna-Q," the "Q" approaches 300 at 4 mc. Used with a 10-meter whip above the coil, the coil is suitable for either base or center loading. With shorting jumpers the coil will serve in the 75, 40, 20, 15, 11, and 10 meter bands. Insulation is polystyrene and fittings are chrome-plate brass.

SPRAGUE "KWIK-TEST"

Sprague Products Co., 51 Marshall St., North Adams, Mass. has recently introduced a new instrument for testing condensers quickly and easily without removing them from the circuit.

Known as the "Kwik-Test," the new unit operates by means of two switches which will indicate whether any by-pass, coupling, or filter condenser within the range of 30 µfd. to 2000 µfd. is open, shorted, or intermittent even when it is in parallel with a resistance as low as 60 ohms.

Condensers between .1 and 2000 µfd.

WAS \$85.00
NOW \$41.95
SAVE \$43.05

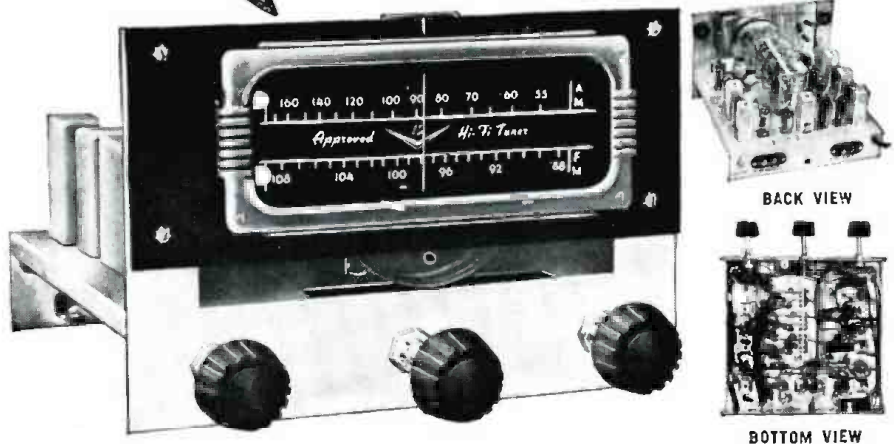

12 TUBE HI-FI FM-AM TUNER AT FABULOUS 50.6% SAVINGS!

TREMENDOUS NATIONAL ACCEPTANCE!

Just a few weeks ago, Radio Shack contracted to buy the ENTIRE output of Approved Electronic's new V-12 tuner. As soon as the word got around that a REAL hi-fi bargain was available, orders have literally poured in; we shipped them out just as fast as they rolled off Approved's assembly line. Yet our stock position now enables us to guarantee AT ONCE delivery — at least for the next few weeks!

EXCLUSIVE AT RADIO SHACK CORP.!

The brilliant new Approved V-12 is available ONLY at Boston's famous Radio Shack — nowhere else in all the world. And at no other place can you buy a 12-tube, double-limiter/FM detector, FM-AM tuner for \$41.95 (or even \$71.55)!

GUARANTEED FM SENSITIVITY!

We flatly (and proudly) guarantee 15 microvolt sensitivity for 20 db quieting on FM, and better in many instances! Compare! Also, the AM sensitivity is far better than V-12's antecedent, the highly regarded Approved A-710.

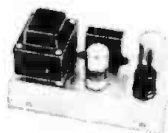

SEPARATE V-12 POWER SUPPLY

110-115V 50-60 cy. Delivers 6.3V @ 4A, 190V DC @ 55 ma. Only 3 1/2 x 4 3/4 x 8", weighs 7 lbs. Built for V-12. Order No. 36-207..... Net \$12.05

Yes! All This For \$41.95 —

- 12 miniature tubes
- Germanium diode
- Double limiters and FM detector
- Tuned RF FM
- Tuned RF AM
- Separate RF, IF stages on FM, AM
- 6-gang condenser
- Cathode follower output 30-15,000 cps
- Band-indic. lamps
- 15 uv sensitivity FM
- Ultra compact chassis
- 8 1/4 W x 5 3/8 H x 8 D.
- Full RETMA guarantee
- Requires 6.3V AC @ 4A, 190V DC @ 55 ma supply.
- Order No. 36-207, 7 lbs.

NOTE: For use with any amplifier, TV, radio; designed especially for high quality hi-fi home systems.

ORDER BY MAIL, PHONE, WIRE! FREE 224-PAGE CATALOG!

RADIO SHACK CORPORATION
167 Washington St., Boston 8, Mass. (Dept. RN)

STAN-BURN E-D-A-R-K-E

CATHODE RAY TUBE SPECIALS

One Year Guarantee

G. E.		STAN-BURN	
* 5TP4	\$44.95	* 10BP4	\$11.00
* 7IP4	17.10	* 12LP4	14.20
* 10BP4A	19.25	* 14CP4	17.00
* 10FP4A	24.00	* 15DP4	19.50
* 12KP4A	27.10	* 16AP4	21.60
* 12LP4A	21.70	* 16FP4	19.60
* 12UP4B	28.25	* 16GP4	21.60
* 14CP4	24.50	* 16PP4A	22.60
* 16AP4A	30.95	* 16DP/HP4	19.60
* 16DP4A (N.U.)	28.20	* 16DP/HP4A	20.60
* 16GP4	31.25	* 16KP4	18.50
* 16KP4/16RP4	28.20	* 16LP4	20.60
* 17BP4A	23.90	* 16LP4A	21.60
* 17CP4	23.90	* 17BP4	18.50
* 19AP4A	39.45	* 17CP4	21.60
* 20CP4	32.50	* 19AP4	25.90
* 20LP4	37.50	* 19AP4A	25.90
* 21EP4A	37.35	* 20CP4	29.50
* 24AP4A	78.50	* 21EP4	32.50

ANTENNAE SPECIALS

* REO DOUBLE "V" Antenna	1-5	6 or more
* 10 ELEMENT CONICAL	52.19	\$1.98
* DOWELED INSERTS	2.98	2.79
* Folded Hi Straight Low Quick Rig		
1/2 elements	4.25	3.25
1 element	4.95	3.75
* WINDOW CONICALS		
5 FOOT SWEGDED	.79	.69
10 FOOT PLAIN	1.39	1.29
NEPCO MASTS	1.69	1.49
* TV WIRE		
42 Mil.		\$ 9.95 M FT.
55 Mil. 300 OHM		11.95 M FT.
72 OHM COAXIAL		35.00 M FT.

* 12 Heavy Slug Spaker.....Special \$3.98

* CHASSIS 630 TECH-MASTER

* Model C-30 with Cascade Tuner.....\$149.50

* OPEN FACE CABINET.....42.00

* WIRE RECORDERS IN STOCK

* Model 9T3C - 2-Speed Tape Recorder.....Write for Price.

* RADIO CRAFTSMAN

* Model C400-Hi-Fi Amplifier.....Net 42.90

* Model C10-AM-FM Tuner.....Net 131.50

* Model C500-Williamson Amplifier.....Net 99.50

* We also carry MASCO-BOGEN-PILOT, etc., Amplifiers, Pre-Amps, FM Tuners and WEBSTER Tape Recorders.

* 6x9 PM Speaker...\$ 3.98

* 7" PM Speaker...3.98

* 77J1 G.E. Flyback...1.98

* 70" Yoke...1.98

* 630 Vert. output upRight...1.98

* 630 Vert. output potted...1.29

* 630 Vert. Blocking OSC. XForm...89

* Cascade Tuners...19.95

* Standard Tuners...17.95

* Dumont 21.25 mc. 14.95

* AUTHORIZED DISTRIBUTORS for General Electric, Kenrad, Tung-Sol, National Union, De Wald, Regal, Automatic and General Motors.

* Automatic Custom-Built Radios for Plymouth, Ford, Chevrolet and many others, always in stock.

* We carry a Complete line of HI-FIDELITY and sound equipment. Send us your requests.

* We also carry a complete line of popular makes of Radio Tubes at 50-10 discount. Also many other special purpose and transmitting types, and all electronic parts and equipment, at lowest prices. Send us a list of your requirements for prompt quotations.

* Terms: 20% with order. Balance C.O.D. All prices F.O.B., NEW YORK Warehouse. Minimum order \$5.00.

* Write for our latest price list and Hi-Fi catalog to Dept. RN-1.

STAN-BURN RADIO and ELECTRONICS CO.

(C.B.S. THEATRE BLDG.)

1697 BROADWAY • NEW YORK 19, N.Y.

may be tested for shorts and intermittent shorts even though in parallel with a resistance as low as 2 ohms.

The new instrument is available in two models, the KT-1 for 115 volts at 60 cycles and the KT-1X for 115-230 volts at 25-60 cycle operation.

Data sheet, M-600, giving full details, is available from the company on request.

C-D CONDENSER KIT

An assortment of 76 of its most popular "Cub" condensers is now being offered by *Cornell-Dubilier Electric Corp.* of South Plainfield, N.J.

The kit is housed in a compartment-type, clear plastic case with a hinged cover, supplied without charge with the condensers.

The "Cub" assortment contains condensers ranging from .001 μ f. to .1 μ f. rated at 600 volts. The company's authorized distributors are handling this new condenser kit.

SINGLE SIDEBAND FILTER

Burnell & Company of Yonkers, New York has announced the availability of an economical sideband filter designed for the amateur market and for manufacturers of low-cost commercial sideband receivers.

The Type S-15000 consists of stabilized toroids and other quality components that will attenuate a 50 kc. carrier 20 db and most of the upper sideband 40 db. Audio response through the filter is 30 cycles to 3300 cycles.

Additional information on this new component is available on request.

COIL CORE

A new high-frequency powdered iron core designed for use with printed circuits has been announced by *Henry L. Crowley & Company, Inc.*, 1 Central Avenue, West Orange, N.J.

The new core lends itself to the dip-soldering process used in many radio and television receivers as well as component printed circuits. The core con-

sists of an upper section of powdered iron available in any of the many types suitable for any frequency application.

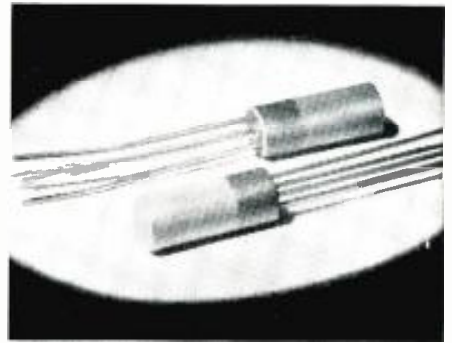

Bonded to the iron core and of the same diameter is the phenolic insulator base. The four wire leads are imbedded in the phenolic section serving as leads for the two coil windings.

CAPACITY DECADE BOX

Precise Development Corporation, 999 Long Beach Road, Oceanside, Long Island, has developed a low-cost capacity decade box which will reach over 1 μ f. at a 1 per-cent accuracy.

Designated as the Model 478, the new unit offers four decades from 100 μ f. to 1.111 μ f. in 100 μ f. steps. The entire unit is pocket-size and measures 3 3/4" x 6 1/4" x 2" in its high-impact Bakelite case. The Model 478 is available in either kit or factory wired form.

UNIVERSAL STANDOFF

Argyle Electronic Co., 8 W. 18th Street, New York 11, N.Y. has designed a new universal standoff that eliminates the metal ring around the transmission line and thus overcomes the problems of standing waves and voltage losses.

The new component permits a close approach to running a transmission line in free space. The grommet is of pure polyethylene of heavy construction, which accommodates all types of

NEW JFD "3-in-one" LIGHTNING ARRESTER



No. AT110 with hardware for wall or window sill mounting, \$1.50, list.

No. AT110S with stainless steel strap for pipe mounting, \$1.75 list.

Both feature the patented JFD strain-relief lips which prevent contact washers from ripping the lead-in wires apart!

one for all... all for one

1. for UHF or VHF tubular twin lead
2. for VHF flat twin lead
3. for VHF or UHF open wire



JFD MANUFACTURING COMPANY, INC.

World's largest manufacturer of tv antennas and accessories; Broun Ln 1, New York

www.americanradiohistory.com

transmission line without the need of threading.

The standoffs are available in wood screw and mast types, singles, duals, and triples.

MAST HOLDER

D. Hale Darnold Company of 914 Kentucky Street, Racine, Wisconsin is now offering a new tower, the SB5.

The SB5 tower stands only three feet high but its all-welded construction enables it to hold a ten-foot mast with sufficient rigidity that no guy wires are necessary, according to the company.

Since in many sections of the country a ten-foot mast is adequate, the new SB5 saves time, material, and labor and simplifies installation. The new towers come with either 1 1/4" or 1 1/2" openings.

PANEL METERS

In order to obtain greater legibility for complex instrument panels. International Instruments, Inc., P. O. Box 2954, New Haven 15, Conn. has devel-

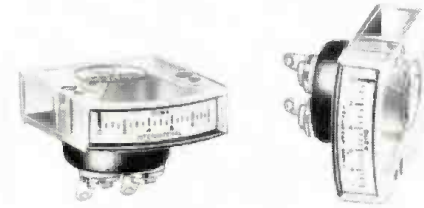

oped a new line of miniature side indicating panel meters.

Available in a wide variety of ranges with flanges for single and back-to-back mounting, these self-contained units can be grouped in both horizontal and vertical arrangements. Two instruments can be placed in the space normally occupied by one large meter.

Ammeters, voltmeters, vu, db, and other meters are available in zero center, left, and right models. Complete information on the Model 1120 meter is available from the company.

SYLVANIA TV TUBE

A new magnetic focus, 90-degree magnetic deflection 21" glass TV picture tube has been announced by the TV picture tube division of Sylvania Electric Products Inc., Seneca Falls, N.Y.

Designed to increase the range of the picture size yet lessen the over-all length of the tube, the new unit has been identified as experimental Type ST-1501 pending an assignment of an RETMA type number. The tube uses a gray, filter-glass, spherical faceplate and a single field ion trap magnet. The over-all length of the new tube is approximately 20 inches. Both aluminized and non-aluminized versions will be available.

TELEX "MONOSET"

Telex, Inc., Telex Park, St. Paul, Minn. has designed a new "Monoset" for professional, business, and technical use.

Made of tough, durable Tenite and

Only 10% Down... 18 Months to Pay!

hallicrafters

I can SAVE you money... Liberal Trade-ins



LEO I. MEYERSON
W6GFQ

S-76 RECEIVER... \$199.95



\$20. Cash Down

\$15.90 per month — 12 months
\$10.90 per month — 18 months

Extra selectivity with double superheterodyne circuit. One RF, two conversion and 3 IF stages. Range 550-1550 Kc, 1.7-34 Mc in four bands. 8 tubes plus voltage regulator and rectifier. Complete with tubes, less speaker.

SX-71 RECEIVER... \$249.95



\$25. Cash Down

\$19.87 per month — 12 months
\$13.63 per month — 18 months

Double Conversion sharp selectivity, plus built-in NBFM at moderate cost. 11 tubes plus voltage regulator and rectifier. Low down payment.

HALLICRAFTERS RECEIVERS AVAILABLE FOR IMMEDIATE SHIPMENT

MODEL NUMBER	DOWN PAYMENT	CASH PRICE	MODEL NUMBER	DOWN PAYMENT	CASH PRICE	MODEL NUMBER	DOWN PAYMENT	CASH PRICE
S-81	\$ 6.00	\$59.95	S-40B	\$13.00	\$129.95	ST-83	\$13.00	\$129.95
S-82	\$ 6.00	\$59.95	S-53A	\$10.00	\$ 99.95	S-78A	\$ 8.95	\$ 89.50
A-84	\$10.00	\$99.50	S-72L	\$12.00	\$119.95	SX-62	\$35.00	\$349.95
S-38C	\$ 6.00	\$59.95	S-77A	\$13.00	\$129.95	S-72 Port	\$11.00	\$109.95
R-46 Speak.	\$ 2.50	\$24.95	HT-20 XMTR	\$44.95	\$449.50	SX-88 Rec.	\$50.00	\$499.95

JUST OFF THE PRESS! Big New WRL 1954 Catalog

Offering the greatest selection of radio & television equipment, parts, and supplies, from "The World's Largest Distributor of Amateur Radio Transmitting Equipment." Order with confidence from "WRL—the world's most personalized radio supply house."

Send for **FREE** Copy

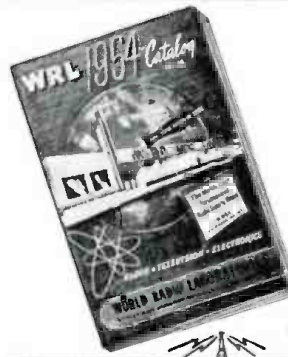

WRITE—WIRE
PHONE 2-0277

WORLD RADIO LABORATORIES R-1
744 West Broadway
Council Bluffs, Iowa

Please send me:

- Radio Map 25¢ WRL XMTR Info
 New Catalog SX-71 Info
 Used Equipment List S-76 Info
 New Log Book

Name

Address

City..... State.....



RU-18 RECEIVER

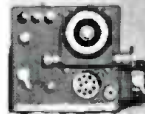

Navy 6-tube aircraft receiver with DF loop and antenna input; complete coverage from 190 KC to 13.9 meg.; in 8-coil sets, less tubes; brand new with any 5-coil sets; you name the freq. you desire; F.O.B. shipping wt., 25 lbs. \$16.95

McCONNELL'S

New Address: BARTO, PA.
Phone: BALLY 5-3623

SKYMASTER Palm Size RADIO

250 MILE DAYTIME RECEPTION
1000 MILES RECEIVED AT NIGHT

Not a toy! This powerful vacuum tube miniature kit covers standard broadcast band 550 to 1600 KC. Hearing aid to 1000 KC. All parts, fit in case. A PERSONAL radio for home, office, camp, etc. Photo diagrams included. ALL PARTS GUARANTEED. Battery plus EXTRA "A" BATTERY, \$1.50. 1500 OHM ALNICO MAGNET powered earphone only \$1.45. C.O.D. orders acceptable with \$1 deposit within U.S. and possessions.



\$6.75 Postpaid
(Factory assembled \$8.95)

PRECISION RADIO ELECTRONICS
Placerville, Calif. DEALERSHIPS AVAILABLE

BARGAIN HUNTING? RADIO SERVICEMEN!
Write for SENSATIONAL CATALOG
HENSHAW RADIO SUPPLY
3619 TROOST KANSAS CITY, MO.

THE
Original
WRENCH
WITH THE
SCREWDRIVER ACTION!



SPINTITE
REG. U. S. PAT. OFFICE

120 STYLES and SIZES

for

- ASSEMBLY WORK
- REPAIR WORK
- RADIO
- TELEVISION
- INDUSTRIAL
- AIRCRAFT



STEVENS WALDEN, Inc.
WORCESTER 4, MASS.

equipped with a volume control for group hearing system applications, the new unit weighs only 1.2 ounces. It has

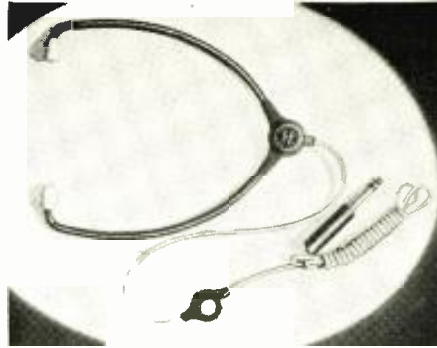

removable plastic ear tips and a miniature plug-in cord attachment. Sensitivity is 88 db above .000204 dynes per square centimeter for 10 microwatts input.

For literature and price information, write Dept. KP of the company, mentioning this publication.

"OCTO-TENNA"

C. R. Derr Co., 1018 Taylor Avenue, Vallejo, California is marketing a new-type television antenna for v.h.f. and u.h.f. reception, the "Octo-Tenna."

The manufacturer claims that this new unit is easy to assemble, convenient to install, and offers little wind resistance. The insulator used with this antenna is made of laminated wood which has been specially-treated to resist weather.

The antenna is sold on a money-back guarantee and the company will supply additional details as required.

VOLTAGE TESTER

Electro Mechanical Instrument Company, 813 Chestnut St., Perkasie, Pa. is now offering a compact voltmeter for testing voltage at the electrical receptacle.

Designed for use by technicians or for resale to customers, the instrument is equipped with prongs that can be plugged into any standard 117 volt receptacle. The prongs have a swivel arc-



angement permitting the meter to be read from any position.

The instrument has a damped meter movement and is mounted in a sturdy metal case. The dial is color-fast and calibrated from 0 to 150 volts. Accuracy is guaranteed to $\pm 5\%$. -30-

New Professional Magnemite*

Battery-Operated Long-Play Spring-Motor Portable Recorder

Specifically designed for maximum professional performance with greatest operating ease. Friction free, ball-bearing drive system enables tape transport mechanism to run 15 minutes on a single wind (at 7 1/2 ips). Dynamically balanced hidden flywheel reduces flutter and wow, equivalent to studio equipment. Incorporates high speed motor rewind (100 seconds). Built-in spring-motor meter continually indicates condition of spring motor. Single knob controls tape and play-record functions. Safety "Record" interlock. 4 Models available in speeds of 3 3/4, 7 1/2 & 15 ips.

Check These Unusual Features:

- ★ High-speed rewind
- ★ 15 Minute play per wind
- ★ Hidden high-speed flywheel
- ★ Ultrasonic bias
- ★ Meets NARTB standards
- ★ 100 Hours battery life
- ★ Size: 7 x 10 x 11 inches
- ★ Weight: 14 lbs.

Write for complete technical literature and direct factory prices to Dept. RT



AMPLIFIER CORP. of AMERICA
398 Broadway, N. Y. 13, N. Y.

*T.M. Reg. U.S. Pat. Off.

QUARTZ CRYSTALS

FT-243-.093" PIN DIA.—.486" PIN SPC FOR HAM AND GENERAL USE

4035 5.303 5850 6.116 7.325 7825	1015 26.015 3985 6.113 1240 8173
4080 5675 5973 6725 7525 7840	1110 2738 6000 6575 7273 8175
4110 5677 5975 6740 7540 7850	1150 2785 6025 6600 7275 8200
4165 5700 6225 6750 7550 7873	1525 2895 6050 6606 7300 8340
4190 5706 6240 6773 7573 7875	1915 2940 6073 6625 7306 8350
4255 5725 6250 6775 7575 7900	1930 3005 6075 6640 7325 8375
4280 5740 6255 6800 7600 7906	1940 3010 6100 6650 7340 8380
4300 5750 6273 6806 7606 7925	1950 3202 6106 7000 7350 8400
4397 5760 6275 6825 7610 7940	2065 3215 6125 7006 7375 8425
4450 5773 6300 6840 7625 7950	2105 3237 6140 7025 7400 8430
4490 5775 6306 6850 7640 7973	2118 3245 6150 7040 7425 8450
4495 5800 6325 6875 7641 7975	2125 3250 6173 7050 7440 8460
4780 5806 6335 6900 7650 8206	2140 3460 6175 7073 8000 8475
4845 5825 6340 6906 7673 8225	2145 3505 6200 7075 8006 8483
4930 5840 6350 6925 7675 8240	2305 3540 6440 7100 8025 8500
5030 5850 6373 6940 7700 8250	2320 3590 6450 7106 8040 8525
5205 5852 6375 6950 7706 8273	2390 3640 6473 7125 8050 8550
5235 5873 6400 6973 7720 8275	2415 3680 6475 7140 8073 8575
5250 5875 6406 6975 7725 8300	2430 3720 6500 7150 8075 8583
5300 5880 6425 7450 7740 8306	2442 3735 6506 7173 8100 8600
5305 5900 6673 7473 7750 8325	2460 3760 6525 7175 8106 8625
5333 5906 6675 7475 7773	2532 3800 6540 7200 8125 8650
5385 5925 6700 7500 7775	2545 3840 6550 7206 8140 8700
5485 5940 7800	2557 3885 7225 8150 8733

49c each—10 for \$4.00

99c each—10 for \$8.00

Low Frequency—FT-241A for SSB, Lattice Filter etc., .093" Pins, .486" SPC, marked in Channel Nos. 0 to 75, 54th Harmonic and 270 to 389, 72nd Harmonic. Listed below by Fundamental Frequencies, fractions omitted.

370 393 414 436 498 520 400 459	5910 2030 2220 2390 3120 3520
372 394 415 437 501 522 440 461	6370 2045 2258 2415 3150 3550
374 395 416 438 502 523 441 462	6450 2052 2260 2435 3155 3570
375 396 418 481 503 525 442 463	6470 2065 2280 2442 3202 3580
376 397 419 483 504 526 444 464	6497 2082 2282 2532 3215 2945
377 398 420 484 505 527 445 465	6522 2105 2290 2545 3232 3955
379 401 422 485 506 529 446 466	6547 2125 2300 2557 3237 3970
380 402 423 486 507 530 447 468	6610 2131 2305 2660 3250 3995
381 403 424 487 508 531 448 469	7350 2145 2320 2940 3322
383 404 425 488 509 533 450 470	7380 2155 2360 3035 3510
384 405 426 490 511 534 451 472	
385 406 427 491 512 536 452 473	
386 407 429 492 513 537 453 474	
387 408 430 493 514 538 454 475	
388 409 431 494 515 455 476	
390 411 433 495 516 456 477	
391 412 434 496 518 457 479	
392 413 435 497 519 458 480	

CR-1A SCR 1/2" P 1/2" S

FT-171B BC-610 2 Banana Plugs 3/4" SPC

Special—200 KCor 500 KC in FT241A Holder, \$1.95 each

add 20c postage for every 10 crystals (or less)

49c each—10 for \$4.00 99c each—10 for \$8.00

BC 746 TUNING UNITS—foundation coils and condenser for 80 meter VFO or exciter—less xtals.....98c

SUN
PARTS DISTRIBUTORS, LTD.

520 TENTH ST. N. W.—WASH. D. C., DEPT. N.

Certified Record Revue
(Continued from page 64)

this principle of as much rigidity as can be built into a given enclosure. Of course, the idea isn't new. Many of you are well aware of such desperate measures as the building of brick or concrete enclosures in the corner of a living room. It goes without saying this is hardly practicable for most people. However, Mr. Briggs, the noted English authority who has long been a proponent of anti-resonant enclosures has come up with what might be some sort of practical solution to the problem. This is to construct the walls of the enclosure of two pieces of plywood say one half or one quarter inch in thickness with a space of an inch or inch and a half or even two inches between the two pieces of plywood. Of course suitable bracing and the gluing and screwing of all joints should be a part of this construction. Then the space between the pieces of plywood should be filled with sand. That's right, sand. This will give you a very heavy and very rigid enclosure which when used with a speaker of proper cone resonance and cone edge treatment will eliminate the boominess we find so objectionable. Of course, the use of sand is practical since whenever the cabinet must be moved it is not too difficult to "drain out" the sand between the retaining walls and you have left a comparatively lightweight enclosure.

That's one answer and, of course, there are variations on this same theme. Whatever they are I feel certain that this will be one of the next improvements in audio and I look forward to a much more sensible and realistic demonstration of sound at the next Audio Fair.

Equipment used this month: *Weathers* pickup and arm, *Fisher* master audio control, *MacIntosh* 30-watt amplifier, and *Jensen* triaxial G610 in *Read* "Fold-a-flex" enclosure.

BEETHOVEN

PIANO CONCERTO #3
Jose Iturbi and the RCA Symphony Orchestra. Victor LM 1759, Orthophonic curve. Price \$5.72.

Mr. Iturbi has not been heard from for a long time, at least on recordings. He is more familiar to us through the medium of motion pictures, etc. A most controversial figure, there are those who state that he has hurt his undoubted talent by his movie work and that his infrequent recordings do nothing to add to his stature. I don't feel one way or the other about this aspect of Mr. Iturbi. To me he has always been one of our better pianists with a particular flair, of course, for music in the Spanish idiom. This recording of Beethoven's third piano concerto is not his particular forte. He plays all the right notes but his tempi is very erratic and as a whole he doesn't project the feeling into the score that some of the other pianists

Best TV Buy You've Ever Seen!

NORTH AMERICAN
PHILIPS
COMPANY, INC.



**235 SQUARE INCH PICTURE
BIGGER·SHARPER·RICHER!**

NEW Norelco TELEVISION

- BIGGER than a 17-inch Tube!
- BIGGER than a 19 or 20-inch!
- ★ Yes—It's Equal to a 22½-inch Tube!

The new NORELCO television receivers give you pictures that are life-like in size and quality, free of glaring whites, rich with velvety blacks and soft grays. Eye-strain free picture.

On NORELCO television receivers you see the whole picture, just as the TV camera sees it. Nothing is cut away. Movie-screen type picture.

With a NORELCO television receiver you enjoy such features as:

TRULY LIFE SIZE PICTURE • AUTOMATIC BEAM SUPPRESSOR • FLAT VIEWING SCREEN • FULL FOCUS • BUILT-IN ANTENNA • HIGH-FIDELITY SOUND SYSTEM • AUTOMATIC GAIN CONTROL • NEW IMPROVED PROTELGRAM (ADVANCED SCHMIDT) BIG-PICTURE SYSTEM DEVELOPED BY PHILIPS WORLD FAMOUS ELECTRONICS LEADER • 23 TUBES PLUS 1 GERMANIUM DIODE • STANDARD TOP QUALITY COMPONENTS, INCLUDING "STANDARD COIL" TUNER • EXCELLENT UHF RECEPTION WITH CONVERTER • FULL SIZE CONSOLE—40½" HIGH, 25" WIDE 21" DEEP • SHIPPING WT.: 124 LBS.

NORELCO'S new, superior TV receivers are engineered for those who demand only the very best!

Write for FREE illustrated, full-color brochure. Send \$1.00 for COMPLETE TECHNICAL MANUAL (Credited against order), or return manual to us and we will refund your dollar. No obligation of course.

SHIPPED IN ORIGINAL FACTORY SEALED CONTAINER

LIMITED QUANTITIES AVAILABLE — ORDER NOW!

TERMS: F.O.B. N.Y.C. Full remittance with order or 25%—Balance C.O.D. Due to this special low price offer, we cannot allow refunds.

ELECTRONIC SPECIALTY SUPPLY CO.
58 Walker Street, New York 13, New York



"The Irvington"—MODEL PT 200—Superb open front, mahogany console cabinet. **GUARANTEED BRAND NEW!**

Interest your friends in this real value and order 3 or more sets for only

\$149.50 EACH

SINGLE SHIPMENTS \$179.50
Original List Price \$399.95
(ATTRACTIVE DEALER DISCOUNTS)



RCA INSTITUTES, INC.

A service of Radio Corporation of America
50 West 4th St., New York 14, N. Y.

OFFERS COURSES IN ALL TECHNICAL PHASES OF RADIO, TELEVISION, ELECTRONICS

Approved for Veterans
Write Dept. RN-54 for Catalog

World's Only Recorder of its Kind
WALKIE-RECORDALL
8-LB SELF-POWERED BATTERY RECORDER

- AUTOMATIC UNDETECTED RECORDING up to 4 hrs.
- PICKS UP WITHIN 60 FT. RADIUS.
- VOICE ACTIVATED "SELF START-STOP"
- NO WIRES OR PLUGS.

Records noiselessly in or out of closed briefcase, containing hidden mike while waiting, riding, typing, conferences, lectures, dictation, 2-way phone. Permanent, unalterable, indexed recording at only 3c per hr.

MILES REPRODUCER CO., INC.
812 Broadway, N. Y. 3, N. Y. Dept. RN-1

POLICE RECEIVERS. Link & Bosch Mobile, 2-3 MC band; satchel control. For marine, ham, C.D., & emergency use. Used but guaranteed good. Complete with 6V dynamotor & chrome case. 1" speaker. ... \$13.50
GROUND PLANE ANTENNAS:
10-20-40 Meters, easily made with our painted-copper-plated WILPIS; threaded tapered sections—16 ft. \$2.45; 32 ft. ... 5.25

NEW SELENIUM RECTIFIERS—Bridge Type

Capacity	1 Amp	2 Amp	5 Amp	10 Amp	20 Amp
2-18 Volts	\$1.35	\$2.20	\$4.50	\$6.75	\$13.25
24-36 Volts	2.15	3.60	8.50	12.75	25.50
90-130 Volts	8.50	10.50	29.75	44.95	87.50

RECTIFIER TRANSFORMER, 115 V./18 V., 2A. \$1.65
METERS, 2" 0-1 MA. \$3.75; 500 MICRO. 5.85
RADIO CONTROL XMITTER & RECEIVER KITS, 27.255 MC: All parts & diagrams (less tubes & crystal) incl. SIGMA 10,000 ohm Relay. 9.95
RELAYS: SIGMA 4F, 8,000 ohm. \$4.50; 3 for. 11.95
MULTIMETER KIT: Basic parts to build 3 MA; 0, 60 600 V. & continuity. 3.15
DYNAMOTORS: 6 V. Input/300 V. @ 165 MA. 9.50
12 24 V. inp. 600 V. 175 MA Output. 9.50
STORAGE BATTERIES: 2 Volts, 3"x4"x5½". 2.75
4 Volts, 68 40-4, 4" x 5½" x 6". 3.95
Miniature 6V. Willard NTB, 2½"x1½"x3½". 2.45
BATTERY CHARGER: 2-0V./75A Ch'ge. Indicator 7.95
CHARGER: For all dry batteries 1½-90 V. 6.50
1/6 HP MOTOR: 12/24 V. DC—OK for 6 V. 5.25
JAN-C-25, Oil Transmuting Mica Condensers. Huge stock. Send us your requirements.

Write for Catalog "N"
FREE: With \$12 order—choice of SENS. RELAY, BC-366, or BALL PEN
GYRO ELECTRONICS CO.
325 CANAL ST., WO. 6-1290 NEW YORK 13, N. Y.

Brand New
Set Mfr's
SURPLUS

TUBES

STANDARD
BRAND
WARRANTY

Bulk Packed in Original Mfr's Nested Cartons or Individually Boxed
Every tube meter and chassis tested for top quality... **BRANDED**

1B3GT54	6AK579	6BQ779	6S0744	12SK749
1L450	6AL537	6BQ6GT79	6T864	12SN7GT49
1R549	6AQ541	6BK771	6V6GT41	12SQ744
1S455	6AG549	6C434	6W4GT41	19B6G61.19
1S541	6AT634	6C544	6W6GT31	19T864
1T449	6AU637	6CB645	6X5GT34	25B06GT82
1U449	6AV634	6CD6G1.11	12AT634	25L6GT41
1U541	6B4G82	6H641	12AT760	35B549
1X2A55	6B555	6H641	12AT760	35B549
3Q5GT58	6BA636	6J5GT37	12AU637	35C549
3S449	6BC549	6J654	12AU749	35L6GT45
3V449	6BE641	6J749	12BA641	35W432
5U4G37	6BG6G1.19	6K6GT37	12BE641	35Z536
5Y3GT34	6BH649	6SA744	12BH756	50B549
6AC771	6BJ649	6SK744	12C849	50C549
6AH664	6BL7GT79	6SN7GT49	12SA749	50L6GT45

More than 400 types in stock. Include all your needs when ordering.

Orders less than \$10.00—add \$1.00 service charge. Terms: 25% with order, balance C. O. D. Please include postage. All prices subject to change without notice. F.O.B. New York City. Mail order division.

TRANSAMERICA ELECTRONICS CORP.

120 LIBERTY ST., NEW YORK 6, N. Y. • COrtlandt 7-4307

MID-WINTER SALE PRICES SLASHED

T.V. TUBES—ROCK BOTTOM PRICES

In lots of 6 each No. only

6B689c	6B657c	1L445c	6X536c
19B689c	39239c	1T449c	6B749c
12AX747c	6CD6\$1.05	6X436c	6AT636c
6CB639c	6S437c	6V6GT38c	6BA638c
6AK563c	6T864c	6W652c	6BE638c

Tube Special—Broken Keys—Electrically Perfect
12A629c; 4 for \$1.00 12X849c; 7 for \$3.00

Tube Sale—2A7-55-27-85-31-56. No Mixed Ass't.
6 of Any Type \$1.75

RCA UV876 Tubes50c

Heavy Duty Shielded P.P. Input Trans. \$1.00

M.D. Silver Contact Trans. Keys 1.00

Insulantite Octal Panel Clamp Sockets 3c ea.

100 Assorted Resistors \$1.95

1 Mfd., 1,000V Oil Filled Cond. 75c

2 Gang Var. Cond. 456 K.C. with Osc. Section, 23 1/2 in. Pulley on 3/8" Shaft 49c

Westinghouse Kudrox Rectifier 0.64 Amp. 28 Volts, Rec. \$11.00 ea. Special \$1.95

BRAND NEW 10" PHONO RECORDS—ASK! \$1.00

Jazz—Popular, Rhythm—Blues, Please specify.
12 for \$1.79 or 24 for \$3.00 or 50 for \$5.75

Single Pole—10 Pos. 2-Gang Switch 29c

Grind your own Crystals—Pure Benzoin Quartz, Various sizes and thicknesses, 1/2 lb. pkg. \$1.00

2-Tube Drilled Chassis, 4 1/2" x 6 1/2" x 1 1/2", 29c each

Signal Corps Phones—2 M. Ohms (8 M. Ohms Imp.) \$1.25

2 Pl. Ext. Cord (ant Plug) 40c

2 3/4" x 4" Bake. Panel Mounting—5 Res.; 6 Mica Cond.; 2 Choke Coils 49c

2 1/2" M.H. R.F. Choke Coil 27c ea.; 4 for \$1.00

7 Ft. Uni. Amp. AC Line Cord 20c

Miniature 7 & 9 Pin Sockets 7c ea.; 60c Dzn.

RCA 4"x6" Oval P.M. Speakers \$1.25

5x7" Oval 1700 Ohm Dyn. Speaker \$1.69

TUBULAR ELECTROLYTICS

20-20 MFD. 150 V. 49c

30-30 MFD. 150 V. 57c

40-40 MFD. 150 V. 59c

80-50 MFD. 150 V. 79c

Low-Loss Short Wave Lock Type Air Trimmer

Variable Condensers

5 Pl.—20 Mmf. 16c

7 Pl.—25-30 Mmf. 18c

8 Pl.—30-35 Mmf. 20c

14 Pl.—56 Mmf. 28c

SWITCH 15c

1,000 OHM WIRE WOUND POTENTIOMETER 15c

30 HY-FILTER CHOKE SHIELDED 3 for \$1.25

PIEZO CRYSTAL HOLDERS, 24 for \$1.25; \$3.50 per C

RCA Band Switches—

3 gang, 3 pos., 3 band, 30c

6 gang, 4 pos., 4-5 band, 40c

Trimmer-Padder Ass't.—all Insulantite—singles, 4c

triples—100 ass't. \$2.25

ATTENTION: Prospectors, Explorers for Hidden Treasures! Construct a U.S. Army Type of Metallic Mine Detector Amplifier, Amplifier unit only (lens tubes and batteries) with cables, headphone cord, and Jack. Army wiring diagram. Type AN/PRN. \$1.95

Pushon push button Rotary Switch Double Pole 35c

8 Gang Push Button Switch Double Pole 49c

DRILLED CHASSIS FOR 5-6 tube 5"x10"x1 1/2" 25c

PHONE JACKS—OPEN & CLOSED AUTO 18c

SALE—PHONO RECORD ALBUMS—12" 3 comp.—19c

10" 5 comp.—15c; 20c; 12 comp.—69c

VULCAN HEAVY DUTY 100 WATT SOLDERING IRON. Built for U.S.N.—Brand New—Equip. sells for \$8.50 OUR PRICE \$3.25

MINIMUM ORDER \$3.00—NO C.O.D.

SHIPMENTS—PLEASE INCLUDE POSTAGE

NEWARK SURPLUS MATERIALS CO.

324 Plane Street, Dept. JA, NEWARK 1, N. J.

AUDELS TV-RADIO SERVICE LIBRARY

HERE IS LATE INFORMATION IN A HANDY FORM FOR RADIO & TELEVISION REPAIRMEN, SERVICEMEN & STUDENTS



2 VOL. \$6 COMPLETE \$1.00 PAY ONLY 1 Mo.

IT PAYS TO KNOW!

AUDELS T.V.-RADIO SERVICE LIBRARY presents the important subjects of Modern Radio, Television, Industrial Electronics, F.M. Public Address Systems, Auto, Marine & Aircraft Radio, Phonograph Pick-Ups, etc. Covers Basic Principles—Construction—Installation—Operation—Repairs—Trouble Shooting. Shows How to get Sharp, Clear T.V. Pictures. Install Aerials—How to Test. Explains Color Systems & Methods of Conversion, 1001 Facts—Over 1260 Pages—625 Illustrations—Parts & Diagrams—Valuable for Quick Ready Reference & Home Study. Tells How to Solve T.V. & Radio Troubles—Answers T.V. & Radio Questions.

Get this information for yourself.

7 DAY TEST—ASK TO SEE IT!

MAIL ORDER

AUDELS Publishers, 49 W. 23 St., N.Y. 10
Mail AUDELS T.V. RADIO SERVICE LIBRARY 2 Vols. \$6 on 7 days free trial. If O.K., I will remit \$1 in 7 days and \$1 monthly until \$6 is paid. Otherwise I will return them.

Name _____
Address _____
Occupation _____
Employed by _____

who have recorded this concerto do. Soundwise this is a puzzling record, because some sections have some really fine, brilliant piano tone quite steady and clean and other sections show noticeable flutter and a distinct percussive hardness of tone. The Orthophonic curve reproduced the disc satisfactorily and surfaces were very quiet. We can't call this the greatest Beethoven's Third Piano Concerto by a long shot; nonetheless if you like Iturbi, it is worth your while.

BACH

ST. MATTHEW PASSION

Amsterdam Concertgebouw Orchestra conducted by Willem Mengelberg, with soloists and chorus. Columbia SL 179, NAB curve. Price \$10.90.

As I've often said before, it's either feast or famine in this LP world. Here is another version of one of Bach's greatest works. What is remarkable is that this is the third recording of this huge opus, a fourth version (Vox) has just been released, and the fifth recording on one of the newer labels is in the offing. Mind you, this music usually requires 4 12" LP sides! Whatever other versions come out, they will have a very tough time competing with this version here reviewed. This recording was made at an actual performance on Palm Sunday way back about 1939. This has always been one work which Mengelberg was acknowledged the greatest interpreter. As many of the older enthusiasts among you know, Mengelberg often was guilty of considerable "free translation," and this liberty-taking of his was much derided. In the St. Matthew, he has chosen to stray very far afield and the result is absolutely magnificent. He manages to keep alive a perfect sense of unity and cohesion, a strong, flowing line, throughout a very long and complex score. His tempi never falters and he maintains an iron discipline over orchestra, chorus, and soloists, no mean feat in this hugely proportioned work. The beauty of this work is indescribable and when it receives the loving, inspirational reading lavished on it by Mengelberg, it becomes one of the great experiences in music. Surprisingly, there is little of the audience or background noises you would expect to hear in a "live performance." The sound itself is remarkably good, considering the age of the recording. It is not up to our present standards, of course, but within its range, a well balanced recording, with good acoustics and only occasional overload distortion to mar its general cleanness. This was not recorded with the NAB curve, in the original; but in transfer to LP has acquired this curve and reproduces well enough from it, with a little cut in bass and treble. Surfaces were quite acceptable. Some of the newer versions undoubtedly will have better sound, but they will have to go a long way to beat this magnificent performance. Listen to all the others; sure. But don't overlook this because of its age.

BEETHOVEN

SYMPHONIES #2 AND #4
 NBC Symphony Orchestra conducted by
 Arturo Toscanini. Victor LM 1723. Price
 \$5.72.

Here are two more examples of Toscanini's survey of all of the Beethoven symphonies. The coupling of the 2nd and the 4th, as two of Beethoven's lesser known symphonies is a good idea musicwise, but it took a lot of courage on Victor's part, since these are probably the least "commercial" of Beethoven's works. The 2nd symphony is the better recording of the two, probably because the 4th was an air check, and these are never wholly satisfactory. Of the many recordings of the 2nd, I have always admired the Walter and the Monteux as the preferred readings. To these I must add this entry of Toscanini's. He brings to the work, his amazing ability to give vitality and life, where others treat the score rather ponderously. I have always considered the 2nd as a somewhat Italianate utterance of Beethoven, which may be the reason I prefer the way Toscanini conducts it. His *tempi* may be considered too fast by some, but I think the work can stand them. I don't know when this recording was made, but whenever it was, the NBC group was certainly at a high peak of perfection. Their playing is a marvel of good balance and precision, coupled with sumptuous tonal qualities. The 4th symphony doesn't come off so well. For some obscure reason, Toscanini chose *tempi* which were entirely out of keeping with this music. Oh, it's played well enough, but it lacks the cohesion and the melodic line, so evident in his reading of the 2nd. Soundwise, the 2nd has it all over the 4th. Restricted frequency response, and compressed dynamic range are typical of the 4th, while the 2nd is a pretty good recording, with clean string tone and sharp, articulate brass and percussion. Acoustically it is a little dry, a common fault of the earlier Toscanini recordings. (However, in all fairness, there are many who prefer this type of sound!) All things considered, I prefer this Toscanini reading of the 2nd, above all others, but when it comes to the 4th, I'll stick by my Weingartner or Walter. I had to experiment with curves a bit, to properly reproduce these recordings. An 800 cycle turnover in the bass with a 10-12 db roll-off in the treble end seemed the most satisfactory. Surfaces were quiet.

FRANCK

SYMPHONY IN D
 Detroit Symphony Orchestra conducted
 by Paul Paray. Mercury MG 50023, AES
 curve. Price \$5.95.

The other day, in the "New York Times," one of the reviewers was commenting rather bitterly about the duplication of repertoire. Of course, he certainly has a point there as a perusal of the LP catalogue shows most of the standard "war horses" have been recorded anywhere from six to

Installing Speakers?

INSIST ON *utah*

Your one complete

SPEAKER SOURCE

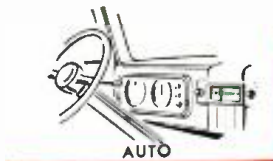

Whether you are making a sound installation in a church, school, tavern, factory or office—or a replacement in an automobile, radio or television set—insist on the tops in the speaker field—insist on Utah Pre-tested speakers.

A Utah speaker is as close to you as your telephone—all leading jobbers handle Utah—because Utah has the widest line of speakers available to the trade—is your one complete speaker source.

The name Utah on a speaker signifies the finest quality in design, engineering, production and performance.

Repeat sales—customer satisfaction—is assured when you insist on and install a Utah Pre-tested speaker.



Radio Products Co., Inc.

Export Dept. Rocke International Corporation—N.Y.C.

A WHOLLY OWNED SUBSIDIARY OF NEWPORT STEEL CORPORATION

When Answering Advertisements Please Say You Saw It in RADIO & TELEVISION NEWS

SCHEMATICS—CONVERSIONS FOR SURPLUS GEAR
 NEW LIST! MANY ADDITIONS!
 Send stamped, self addressed envelope for List C. Add 25c for chart explaining AN nomenclature.
R. E. BOX 1220 GOODHEART BEVERLY HILLS, CAL.

3000 MILES of TELEPHONE WIRE at 1947 PRICES..

7th ANNIVERSARY SALE
 Wire Prices Rolled Back for This Special Sale
ALL PURPOSE—ALL WEATHER

Genuine W110B ARMY FIELD WIRE on original steel-reels insulated, 2-conductor copper-steel strands. Excellent for all types of communication. Used extensively by telephone companies, industry, engineering projects, etc.

GR. 1—Unused, excellent condition, mile reels (5,280 ft.) 160 lbs.	\$16.00
1/2 mile reels (2,640 ft.) 80 lbs.	9.00
GR. 14—Unused, good condition. Mile reels, \$11.50. 1/2 Mile	6.50
W-130 #22 ga. new, 2-cond. plastic insul. 1,560 ft. reels \$34.50. 3,500 ft. reels	16.00
EE-8—ARMY FIELD Phones, factory re-conditioned like new, per pair	42.50
EE-91—FIELD Phones, Factory checked. Dist	34.50

Write for free folder. Send check or M.O. No C.O.D.'s Prices F.O.B. Sacto. California Buyers Add 3% Tax.

LORIS SALES
 P.O. Box 1896 M-1, Sacramento, California

BECOME AN ELECTRICAL ENGINEER



Bachelor of Science Degree in 36 months.

Major in Electronics or Power. Now, prepare for a career in these rapidly expanding fields.

This school will prepare you to become an engineer, technician or service man. Previous military, academic or practical training may be evaluated for advanced credit.

Enter Both Radio and Television

In 12 months you can attain the *Radio-Technician's* certificate. An added 6 months course qualifies you for the *Radio-TV Technician's* certificate and the Degree of "Associate in Applied Science." The Technician's course is the first third of the program leading to a Bachelor of Science Degree in Electrical Engineering with a major in Electronics.

Also offered: 12-month Radio-TV service course; 12-month Electronics or Electro Technician Courses; 6-month Electrical Service Course and 3-month refresher and general preparatory classes.

Terms Open April, July, Sept., Jan.

Famous for its Concentric Curriculum. Faculty of specialists. 50,000 former students. Annual enrolment from 48 states and 23 overseas countries. *Non-profit. 50th year.* Courses approved for Veterans. Residence courses only.



MILWAUKEE SCHOOL OF ENGINEERING

MILWAUKEE SCHOOL OF ENGINEERING
Dept. RN-154 1025 N. Milwaukee
Milwaukee 1, Wisconsin

Send: Free 45-page "Your Career" booklet describing Electrical Engineering Courses;
 Booklet on Careers in Radio-TV.

I am interested in..... name of course

Name..... Age.....

Address.....

City..... Zone... State.....

If veteran, indicate date of discharge.....

even 18 or 19 times in different versions. That this duplication is unfortunate is to put it mildly, but consider the position of recording companies faced with the prospect of spending a lot of money on a comparatively obscure work in the hope that somehow the public will appreciate this effort and make the investment worthwhile. It is a big chance for them to take and most of them just won't do it. Instead they'll draw again and again on the standard repertoire and try to give their offering some new twist or new sound, anything that will make it salable. With such a multitude of recordings on standard works, one can afford to be particularly choosy in matters of interpretation and sound. This Franck symphony by Paray and the Detroit Symphony is the twelfth LP version. Of the 12, I would say that this ranks along with the Monteux version on *Victor*, the Mengelberg on *Capitol*, and Munch on *London*. The rest are either such bad recordings or poor interpretations as to be unimportant. Once more as in the case of Munch and Monteux, we have a French conductor, Mr. Paray. His is a very sonorous and powerful reading, with more clearly delineated tonal masses than the *Victor* or *London* disc. In this somewhat redundant symphony, he manages a *tempo* which keeps you from becoming bored. Interpretively I would say he has definitely the edge on Mengelberg and is on an equal footing with Munch. Soundwise this is far the best version yet recorded. The strings, especially the bass viol, are very rich and vibrant, the woodwinds and percussion cleanly articulate. I feel that this symphony needs the very finest in recording especially in the low end, if it is to come off successfully. This recording meets this challenge and for those of you who are somewhat jaded with Mr. Franck I suggest you try this one. The AES curve reproduces the recording satisfactorily although on some systems it might be necessary to cut the bass control a db or two. Surfaces were quiet in my copy.

SHAKESPEARE MACBETH

Old Vic Repertoire Company. *Victor LM 6010.* NAB curve. Price \$11.44.

It is not often that we review recordings of the spoken word but I feel they are, in their way, just as important as our musical recordings. Certainly they have been vastly improved over the past few years as far as technique is concerned, and none will deny that LP is the ideal medium for the presentation of lengthy plays. Having heard the Old Vic Company while overseas in England, I was hoping that someone would get around to recording some of their best. This *Macbeth* is welcome indeed and if you've got the time to sit yourself down before a roaring fire on one of those long cold winter nights this is quite an experience. The dialogue is crisp and clear and the flow and continuity

CRYSTALS

LARGEST STOCK

IN THE WORLD



In FT 241-A Holders—1/2 in. Pin SFC. These are designated 54th

or 72nd Harmonic MC freq. Listed by fundamental freq. with fractions omitted.

NOTE! HUGE PRICE REDUCTIONS! FREE GIFT OFFER BELOW.

COMPLETE SET—80 CRYSTALS
Ranging from 370-518 Kc. & 455 Kc. crystals. Only... Per set **\$6.95**

COMPLETE SET—120 CRYSTALS
Ranging from 370-540 Kc., 72nd Harmonic, PLUS 500 Kc. & 455 Kc. crystals. Only... Per set **\$9.95**
200 KC. CRYSTAL..... Ea. \$1.75
500 KC. CRYSTAL..... Ea. 2.75
1,000 KC. CRYSTAL..... Ea. 2.75

FREE WRIST COMPASS—on request with every \$15.00 order for crystals.

All crystals sold as is, and sent postpaid. WRITE FOR QUANTITY DISCOUNTS!

MISCELLANEOUS BEST BUYS

ARW-2 Remote Control Receiver
10-channel audio-tone receiver. Ideal for radio control, garage door opener, lawn mower, model boat and many other electronic control devices. Here are some of the parts it contains: ten 10,000-ohm resistors, 13 audio filter sections, 14 standard size tubes, 2 crystals, 24 V. power supply, plus many other useful items. ALL NEW. An unobtainable value at **\$27.50** ONLY

APS-13 TRANSCEIVER: Complete with tubes and dynamotor. Easily converted to 120 MC. Excellent sound. \$14.95

PE-73 DYNAMOTOR. Used. As is... \$3.49
BARBEQUE MOTOR. AC. New... 9.45

SPECIAL COMBINATION!
WILLARD 6 V. plastic storage battery for model control equipment. Uses standard electrolyte. NEW. (Orig. sold for \$2.49) PLUS REVERSIBLE MIDGET MOTOR. Operates on 1 1/2 6 V. at top speed of 10,000 RPM. (Orig. price \$1.95). NEW. BOTH units now only **\$2.75**

Prices net F.O.B. Los Angeles. All items subject to prior sale.

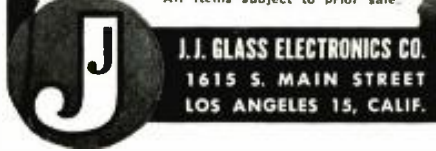

J. I. GLASS ELECTRONICS CO.
1615 S. MAIN STREET
LOS ANGELES 15, CALIF.

Don't Miss a One of the Exciting New Developments in Electronics. Keep Up Your Subscription to **RADIO & TELEVISION NEWS**

Circulation Dept.,
64 East Lake Street,
Chicago 1, Ill.

of the action is well maintained. The excellent cast knows its Shakespeare and the whole effect is a very intimate and compelling picture of this grisly tale. Super quiet surfaces lend themselves in maintaining the illusion of an "on the stage" performance. Definitely recommended for those of you who enjoy the English language as put together by Old Will Shakespeare.

HINDEMITH
SYMPHONIC METAMORPHOSIS ON THEMES OF CARL MARIA VON WEBER
SCHONBERG
FIVE PIECES FOR ORCHESTRA
 Chicago Symphony Orchestra conducted by Rafael Kubelik. Mercury MG 50024, AES curve. Price \$5.95.

With these Hindemith and Schonberg pieces and with the Mozart symphonies numbers 38 and 34, Rafael Kubelik ends his recording with the Chicago Symphony Orchestra. This is to me a very sad thing, for Mr. Kubelik has been a favorite of mine ever since his sensational debut in "Pictures At An Exhibition." He has shown constant improvement in everything he has done since then, and I feel he could have gone on to become one of the most highly gifted recording conductors we have ever had in this country. In this recording Mr. Kubelik gives further evidence of his considerable attainments. The Hindemith is most welcome, as the only other recording on LP (that by George Szell and the Cleveland Orchestra) is showing its age. The Szell, considering the time when it was recorded, was a very satisfactory recording but one can not say truthfully that it was the last word on the work. This new version is a delight to hear with all of Hindemith's jazzy orchestrations being given beautifully clean, distortionless recording. The second movement, which is the famous fugue based on Chinese themes, has never "swung" so much, and sounds almost like "Birdland" on a Saturday night. There is much here that hi-fi addicts will appreciate. Wonderful percussive effects with tympany and assorted gongs and bells. If you want a real thrill and also an appreciation of the tremendous dynamic range of this disc, play about the last quarter inch of the first movement and some of the heavy climactic brass and bass drum scoring will knock you off your feet. Mr. Kubelik's reading of this complex work is a model of good taste and orchestral balance. He may often have been thought of as a conductor primarily concerned with works of Czechoslovakian or Bohemian origin. Those who know the man, know that he is very much at home with the moderns, as this splendid and vigorous reading will testify. The Schonberg is a first recording on LP. The five pieces for orchestra are some of the most atonal and dissonant works he ever wrote and among the most interesting. Here is true mastery of orchestration. These pieces run the

January, 1954

NEW—LOW—LOW PRICES

COMMAND RECEIVERS AND TRANSMITTERS:

BC-454—RECEIVER—3 to 6 MC.	Used: \$10.95
BC-455—RECEIVER—7 to 9 MC.	Used: 9.95
FT-220—Three RECEIVER RACK.	New: 2.50
FT-221—Three RECEIVER SHOCK MOUNTING.	New: .95
BC-450—3 REC. CONTROL BOX.	New: \$2.00 Used: 1.50
DM-32—DYNAMOTOR.	New: \$6.95 Used: 2.95
BC-459—TRANSMITTER—7 to 9 MC.	Used: 14.95
BC-457—TRANSMITTER—4 to 5.3 MC.	Used: \$12.95
T-20 ARC-5—TRANSMITTER—1 to 5.3 MC.	New: 18.95
BC-458—TRANSMITTER—5.3 to 7 MC.	Used: 9.95
BC-459—TRANSMITTER—7 to 9 MC.	Used: 14.95
T-22 ARC-5—TRANSMITTER—7 to 9 MC.	Used: 16.95
T-23 ARC-5—TRANSMITTER—100 to 156 MC.	Used: 34.95
BC-456—MODULATOR.	Used: 2.95
BC-451—CONTROL BOX.	New: \$1.50 Used: 1.00

BC-375 TRANSMITTER AND ACCESSORIES

BC-375—TRANSMITTER—100 Watts. w/ Tubes.	Used: \$37.95
TUNING UNITS—BC-306.	\$3.95;
TU-7-8-9 or 10.	Ea. \$2.95
CABLES—with PL-61, PL-64 or PL-59 ea. end.	Ea. \$2.50
MOUNTING FT-151.	\$2.50
Extra Set of Tubes.	\$2.50
DYNAMOTOR PE-73 28 V. U.	\$8.95
BD-77/14 V.	Used: \$22.50

COAXIAL CABLES:

RG-8/U (SPECIAL) 51.5 ohms. Same size as RG-8/U. Prices: 1 to 100 ft. @ 3c per ft.—100 to 500 ft. @ 7½c per ft.—500 to 1000 ft. @ 7c per ft.—1000 ft. Roll @ 6½c per ft.	
RG-34/U—71 ohms. 145 ft. length.	\$15.00

CRYSTALS:

CRYSTALS—DC-34-35 for BC-669 Transmitter—¾" Spacing. Frequencies: 1746—2340—2665—2725—2980—3000—3280—3830 and 4255. \$1.95 Each

ANTENNA EQUIPMENT

MAST BASES—INSULATED:

MP-132 BASE—Illustrated at left—1" heavy coil spring, 2" insulator. Overall length: 1½". Weight: 2¼ lbs. Price:	\$3.05
MP-S-33 BASE—Insulated type with heavy coil spring and 5" dia. insulator. Requires 2" hole for mounting. Weight: 9 lbs.	\$5.95
MP-48 BASE—Insulated type base with heavy coil spring. Requires 1¾" mounting hole. Weight: 11 lbs.	\$6.95
MP-37 BASE—Insulated type with heavy coil spring: 7" dia. insulator; requires 1¾" hole for mounting. Weight: approx. 10 lbs.	\$8.95

MAST SECTIONS FOR ABOVE BASES:
 Tubular steel, copper coated, painted in 3 ft. sections, screw-in type. MS-53 can be used to make any length with MS-52-51-50-49 for taper. Any section. @ 50c each. Larger Diameter Section: MS-54. \$1.25

TRANSFORMERS

110 V. 60 Cycle Primaries

5 Volt CT-25A—10,000 V. Ins. OPEN FRAME—6" x 5" x 4½".	\$7.95
6.3 V. 1 Amp.	1.25
24 V. ½ Amp.	1.50
6—24—or 30 Volt 8 Amp.	5.95
24 V. 1 Amp.	1.95
24 V. 6.5 Amp.	5.95

FAIR RADIO SALES 132 SOUTH MAIN ST. LIMA, OHIO

*****HEATHKIT*****
 ★ INSTRUMENTS ASSEMBLED & TESTED ★
 ★ Take advantage of Heathkit's engineering skill and our construction ability, at far less than ready-made instruments of equal calibre or quality. ★
 ★ A T-1 Transmitter (16 lbs.) \$44.50 ★
 ★ A R-2 Communications Receiver (12 lbs.) 38.95 ★
 ★ V 6 V.T. Voltmeter (6 lbs.) 35.50 ★
 ★ Please include postage. (We refund overpayments.) ★
 ★ Any of the 40 other Heathkit instruments at comparable prices. Workmanship fully guaranteed. ★
 ★ Write for full details. ★
 ★ R. A. MOOG CO. 51-09 PARSONS BLVD. FLUSHING, NEW YORK ★
 ★*****

CODE SENDING SPEED

Be a "key" man. Learn how to send and receive messages in code by telegraph and radio. Commerce needs thousands of men for jobs. Good pay, adventure, interesting work. Learn at home quickly through famous Candler System. Quality for Amateur or Commercial License. Write for FREE BOOK.

CANDLER SYSTEM CO.
 Dept. 2-A, Box 928, Denver 1, Colo., U.S.A.

FREE CATALOG

JUST OFF THE PRESS—OUR NEW SURPLUS CATALOG! SEND FOR YOUR COPY!

SOUND POWERED HEAD AND CHEST SET

Navy Type—No Batteries Required—Ideal for TV Antenna Installations and many other uses. 20 Ft. Cord. Used Tested: **\$5.95 EA.**



TELEPHONE WIRE FOR THE ABOVE

COMBAT TYPE—2 Cond. Twisted. Rubber Covered. Medium Weight, W-130. @ .01c per Ft.
 FIELD WIRE—2 Cond. Twisted. Weatherproof. Heavy Duty, W-110—525 Ft. Roll. **\$4.75**
 COPPER WELD WIRE—Weatherproofed, 2 Cond. Solid. 1200 Ft. Roll. \$10.00. Per Ft. @ .01c per Ft.

BLOWERS—115 VAC 60 CYCLE

SINGLE TYPE: (Illustrated at left) 100 CFM. 2¼" intake; 2" outlet. Complete size: 5" x 6". Order No. 1C939.	\$8.95
DUAL TYPE: 100 CFM. 4" intake; 2" Dis. Each Side. Complete Size: 8" x 6". Order No. 1C880.	\$13.95
COMPACT TYPE: 108 CFM. Motor built inside squirrel cage. 4½" intake; 3¾" x 3" Dis. Complete size: 4¼" W x 8¾" H x 8¾" D. Order No. 2C067.	\$14.50
FLANGE TYPE: 140 CFM. 3½" intake; 2½" Dis. Complete size: 7½" W x 7¼" H x 6¼" D. Order No. 1C870.	\$13.95
FLANGE TWIN: 275 CFM. 4½" intake; 3½" x 3" Dis. Complete size: 11¾" W x 8¾" H x 8-1/16" D. Order No. 2C069.	\$21.95

AERIAL WIRE—Phosphorus Bronze #16 Strand—200 lb. test. Weatherproof, 150 Feet on Reel. RL-3 with Clips **\$1.50**

DYNAMOTORS:

INPUT: 14 V.D.C. 12 V.D.C. 12 or 24 V.D.C.	OUTPUT: 330 V. 135 MA. 50 V. 50 MA. 500 V. 50 MA.	STOCK No.: DM-330 DM-25 USA/0515	PRICE: 8.95 7.95 4.95
DYNAMOTOR UNIT—PE-133—12 Volt input; output 230 VDC 90 MA. Filtered. Dyn. 5½" x 3½". Filt. Base: 3" x 4" x 5". NEW: \$7.95			
PE-103 DYNAMOTOR —Used: \$24.95			
DYNAMOTOR—PE-101—6 or 12 Volt. (Reprints of original CQ conversion articles—Oct. & Dec. '52 issues, furnished.) This is the Dynamotor the Hams have been talking about! Easily adapted to supply 625 V. @ 150 MA. and 325 V. 125 MA. @ 12 Volts—or 300 V. 90 MA. and 160 V. 110 MA. @ 6 Volts. NEW: \$4.95			

BATTERY SWITCHING UNIT and METER

Used to switch load from one battery to another—or 5 to 12 Volts. Contains 2" Meter —0-15 Volt. DC Scale for reading battery voltage. 20 Amp DPDT Switch and indicator. Case size: 4" x 6¼" x 2¼". NEW: \$2.95

Address Dept. RN • Minimum Order \$5.00 • Prices F.O.B. Lima, O. • 25% Deposit on C.O.D. Orders

CORONA RADIO KITS

• Easy Assembly • Excellent Reception

SINGLE BAND SUPER
 Rocket 115K—Latest superhet circuit for ultimate in sensitive reception and tonal quality. Kit includes all necessary parts—punched chassis, attractive bakelite mahogany cabinet, built-in loop antenna, iron core IFA, bias-treble tone control, 5" Alnico PM Spkr., phone jack. Handsome bakelite mahogany cabinet. 1½"x8"x6½". Tubes: 12SK7, 12SA7, 12SQ7, 50L6, 3Z5Z. Automatic vol. control, beam power output. Tunes 540 to 1700 Kc. Simple step-by-step instructions included. **\$14.75**

2 BAND AC-DC SUPER
 Plaza 812K—Excellent sensitivity. Tunes standard Broadcast 535 to 1800 Kc. foreign short-wave 6 to 18 Mc (16.6 to 50 meters). Features iron core IFA, bias-treble tone control, 5" Alnico PM Spkr., phone jack. Handsome bakelite mahogany cabinet. 1½"x8"x6½". Tubes: 12SK7, 12SA7, 12SQ7, 50L6, 3Z5Z. All parts, punched chassis, easy step-by-step instructions included. **\$20.75**

3 BAND SUPER Globemaster 814K Complete Kit **Net \$24.75**

All kits supplied less wire and solder. Please include 25% deposit with C.O.D. Orders. Dept. N-1

CORONA RADIO & TV CO.
 136 LIBERTY ST., NEW YORK 6, N. Y.

STAY ON THE AIR WHEN POWER FAILS...with an ONAN Electric Plant



**AUTOMATIC
START & STOP**

Model 10EL, 10KW A.C.

When storms, floods, or fires interrupt electricity and force you off the air, you lose listeners and income. Guard against loss, assure vital public service during emergencies by installing an Onan Electric Plant. Onan Standby Electric plants serve many network and private stations. Gasoline driven automatic models to 50,000 watts.

PORTABLE ELECTRIC PLANTS FOR MOBILE RADIO USES



Supply A.C. power for broadcasting at scene of events. Light in weight. Can be carried by hand or in trunk of car. A.C. models: 400 to 3,500 watts.

Write for **FREE Folder**



D. W. ONAN & SONS INC.
7900 University Avenue
Minneapolis 14, Minnesota

SPECIAL VALUES

783 Outlat Power Meter General Radio. Like New	\$225.00
LR-1 Signal Generator 100-30,000 KC. 115VAC, 60 cy. with xtal calibration. Exc.	1,200.00
Model 225X Hickok Universal crystal controlled Signal Generator. Like New	125.00
Model 200C Hewlett Packard Audio Generator	100.00
Model 210AR Hewlett-Packard Square Wave Signal Generator	100.00
T67/ARC-3 Transmitter, Receiver, Mounts, and Modulator with Dynamotor	PUR*
R65/APN9 Receiver-Indicator	PUR*
Du Mont 208B Oscilloscope	125.00
RTA-1H Bendix Transmitter	PUR*
Model 230 Clough Brendle AC Cap. & Res. Turns Ratio Bridge	45.00
Type 726A General Radio Vacuum Tube Voltmeter	125.00
S94 Federal or General Radio Signal Gen. 8-330 mc.	300.00
RC-221 or LM Freq. Meter	99.50
RC-221AK with modulation	150.00
General Electric Dual Regulated Power Supply Type ST9A	New 300.00
Type T243 Precision Wavemeter General Radio, 16 KC. to 50 mc.	175.00
A LARGE STOCK OF ARC-1, ARC-3, ART-13, APN-4, APN-4B, APR-4, ARB, BC-312, BC-342, BC-348, BC-433G, BC-611, BC-1306, CRT-3, 196A, 1222, 1E-19A, 1E-35A, 1E-36A, SCR-284, SCR-522, SCR-578, SCR-625, TCS, T19/APQ5, TS-34/AP, TS-100/AP, TS-184/AP, 14C, Plugs and Selsync	PUR*

WANTED

All types of radio and electronic surplus. We especially need: 6AP10, 6AP9, 6AP4, 6AK4, 6AR1, 6AR3, 6AR13, 6ATC, 6C221, 6C342, 6C348, 6C611, 6C721, 6Y12, 6Y17, 1140, 1M10 to 1M18, 6G149F, 6G149H, 6U14, 6S/ARN7, 6SA 6RN7, 6SR718C, TCS, TNL, TS17, TS19, TS54, TS5, TS12/AP, TS33, TS35, TS43, TS73, TS76, TS102, TS147 UP, TS148/UP, TS173, TS174, TS175, TS250, TS251, TS223, (1CF, 1E, 1G, 5CT, 5PG, 5P, 5G, 6PG, 6G, 115V, 60 c.p.s. Selsync), and all types of Hewlett Packard, General Radio Co., Measurements Corp., Bounton Radio, Ferris, Leeds & Northrup, and other test equipment. Please state accurate description, condition, and your lowest price. Explain modification, if any. We pay freight charges.

NEW CATALOG NOW AVAILABLE

PHOTOCON SALES

417 N. Foothill Blvd. Sycamore 2-4131
Pasadena 8, Calif. RYan 1-6751
CABLE: Photocon, Pasadena.

gamut from the most subtle and delicate of orchestral effects to some of the most dynamic and dramatic performances ever written for full orchestra. Again this disc is noteworthy for its unusually wide dramatic range. This is extremely intricate music and Mr. Kubelik is to be congratulated for maintaining such rigid discipline in the different sections of the orchestra, and the orchestra in turn should come in for its share of the plaudits for its magnificent playing. This is not the kind of music your wife will take kindly to on first listening, but if you can disassociate your mind from the prejudices many people consciously or unconsciously have about modern music, you will find this piece most interesting and intriguing. With the bass and treble controls set at flat positions the disc reproduced well from the AES curve, surfaces were very quiet. All in all, an "off the trail" composition that is well worth your attention.

International Short-Wave

(Continued from page 83)

Mozambique — Lourenco Marques, 4.916A, noted 2300-0200. (Dodge, Mass.) Heard on 3.480 at 2300 with identification, then popular music; on 4.916A at same time but at weaker level. (Cox, Dela.) Noted with Portuguese on *new* 4.875 channel around 1300. (Catch, England)

New Caledonia — Noumea is now scheduled 1400-1500, 1900-2100, 0200-0530 on *new* 3.375, 500 watts, and *new* 6.028, 1 kw. (Scheiner, N. J.)

Norway — LKQ, 11.735, Oslo, noted at fine level 2000-2100 to North America. (Dodge, Mass., others) *Winter* schedule to Eastern North America is 2000-2100 (Sun. to 2120 when has "Norway This Week" in *English*), and to West Coast North America 2300-2400 (and Mon. 0000-0020 with "Norway This Week") over 7.210, 9.610, 6.130, 1578 kc. (Halvorsen, Norway)

Okinawa — VOA, 7.16, noted signing on 0500 at fair level. (Balbi, Calif.) Is scheduled 0500-0945 to China-Korea.

Pakistan — Karachi, 17.71, signs on 0200 with news for East Bengal; heard with *English* 0515 on 17.77; news 1015-1030 on 9.484; now uses 6.235 and 7.010 to Turkey and United Kingdom 1530-1615; heard with news 0730-0740 over 15.620, good level; signs on to Indonesia 0630 on 17.77, 15.335. (Pearce, England) Heard on 15.335 at 1930 with news; on 11.914 at 2020 with *English* program of news, music. (Sanderson, Australia) Heard on 7.095A with news 0730-0740, then in native to *past* 0800. (Stark, Texas)

Panama — HP5J, 9.607, noted at fair level 1225 announcing "La Voz de Panama;" heavy QRM. (Ferguson, N. C.) HOFA, *Onda Popular*, is *new* s.w. outlet for HOF, heard signing on 0630 on 9.687; also heard around 2100. (West, Va.)

Philippines — DZB2, 3.340, noted 0500

Spot TV trouble symptoms at a glance

... fix them twice as fast!

Now! HANDLE UP TO 90% OF TV SERVICING BY PICTURE ANALYSIS

New short cut way of handling television service can save you hundreds of dollars worth of time



PIX-O-FIX TV TROUBLE FINDING GUIDE

By Ghirardi & Middleton

- 24 COMMON television troubles identified by actual TV screen photos.
- 190 POSSIBLE causes of these troubles identified and localized to the particular stage of the receiver where they are most likely to occur.
- 253 DEFINITE, easily understood remedies for these troubles.
- 4,500 WORDS in CAUSE and REMEDY section to explain exactly what to do.

FAST! EASY TO USE!

Hours of tedious, time-consuming troubleshooting can be cut to minutes. Repairs can be made twice as fast! Just "dial" the new Ghirardi PIX-O-FIX TV TROUBLEFINDER GUIDE until the actual TV screen photo appearing in its "window" matches the screen picture on the defective set you are repairing. The proper Trouble Key Number also appears on the guide. This directs you to the tabulation giving all possible causes of this particular trouble and the stage or section of the receiver in which it is most likely to occur.

But this only the beginning! The Pix-O-Fix Guide not only helps you locate the trouble quickly but then also shows you exactly how to fix it. Step-by-step repair instructions follow in most cases; the particular component most likely to be faulty is specified. Quick tests to apply to it are explained. If part substitution is likely to be more effective than an instrument test, this is recommended.

COVERS ALL MODELS!

PIX-O-FIX is applicable to all television receivers. Operation is clear and simple. Money-back guarantee if you're not more than satisfied!

NOTE! Ghirardi's PIX-O-FIX is designed and sold as a professional TV service device for servicemen—NOT as a "fix-it-yourself" gadget for use by consumers.

Only \$1. 10 DAY Money back Guarantee

Dept. RN-14, Rinehart Books, Inc., Technical Div.
232 Madison Ave., New York 16, N. Y.

Enclosed is \$1 for which please rush a PIX-O-FIX TROUBLE FINDER GUIDE. If not satisfactory, I will return it postpaid within 10 days and you guarantee to refund my \$1.

Name
Street
City, Zone, State
PRICE OUTSIDE U.S.A. \$1.25 cash—same return privilege.

with religious program; DUH2, 6.17, heard 0545 in Home Service with news, music; DZH2, 6.000, noted 0445 with news, music. (Sanderson, Australia) Far Eastern Broadcasting Co., 9.73A, Manila, noted 0700-1100 with music, news, religious programs; also plays requests; strong around 1000. (Demattei, Calif.) This organization will have a low-powered transmitter in service in March on 21.475, which will make a transmitter in each of the international s.w. bands, the tropical band, and on m.w. (Radio Australia)

Poland—Radio Warsaw, 7.105A, noted with news in Spanish for Spain 1530-1600; English at 1430, 1730, 1800; at 0130 in English on 9.555. (Pearce, England) Heard signing on 0600 in English on 11.74. (Golden, Mass.)

Portuguese India—Radio Goa, 9.61, is noted Sun. 0845-1015. (Persson, Sweden)

Roumania—Bucharest signs on English 1430, audible in Britain on 9.252, 9.57, 6.21. (Pearce) Noted on 9.57 with English for North America 2200-2225, then interval signal to 2230. (Niblack, Ind.) Heard on this channel 1415 in French. (Bellington, N. Y.)

Saudi-Arabia—Djeddah, 7.095A, noted with native chanting 2307, weak level. (Cox, Dela.)

South Africa—Cape Town, 5.892, noted 1300 with Afrikaans session, fair level. (Catch, England)

South Korea—HLKB, 7.935A, Pusan, noted 0430 with Western music, then commentary in English. (Sanderson, Australia)

Spain—Radio Juventud de Murcia, 7.104A, noted closing with two anthems 1800; relays news in Spanish from Madrid. Radio Nacional de España en Malaga, 6.18, heard closing with Spanish National Anthem 1835A. (Pearce, England) Radio Falange, Alicante, has dropped its s.w. outlet.

Surinam—The 15.408A channel is good level around 1800. (Gay, Calif.) The 5.752 outlet noted 2015 in heavy CWQRM. (Briem, Iceland)

Syria—Damascus, 11.913, noted with English 1630-1730 closedown. (Zerosh, Pa., others) Is scheduled to Latin America 1900-2100 in Arabic, Spanish, Portuguese over 11.695, 11.915. (Scheiner, N. J.)

Switzerland—Winter schedule to North America is 2030-2300 over HER3, 6.165; HE13, 7.210, and HER4, 9.535; Pawlik, Mass., finds 7.210 at good level from 2030.

Taiwan—Heard on 7.334 at 0700 with Western music, Chinese news; BED26, 10.080A, noted 0615 with Western music, Chinese news; BED6, 11.735, noted 0030 with news, commentary, music; BED3, 15.235, heard 2315 with news, music; BED32, 9.778A, heard 0400 with Western music, Chinese news. (Sanderson, Australia) Taipeh's BEC25, 6.095, noted on Sun. with "Bible Hour" at 0530, fair level, some QRM. (Balbi, Calif.) Taipeh still invariably verifies BED as 11.800 but all reports say is actually heard on 11.920. (Japanese Short Wave Club)

Tangier—Radio International has

Exciting New Performance . . . Superb Cabinet Craftsmanship

THE PERMOFLUX

Fortissimo

2-Way Speaker System with "DUAL DRIVING POINT" Horn Design

Now Brings You

FULL RANGE HIGH FIDELITY
At Either Low or High Volume Level

Perfection
in Cabinetry
by
Contemporary
American
Furniture
in
Mahogany or
Korina Blonde.

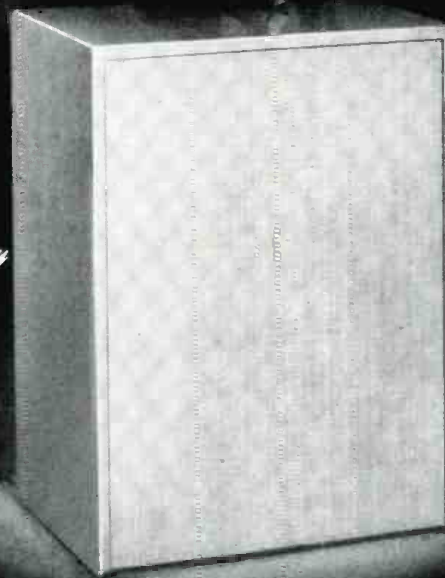

Unique "New Dual Driving Point" Enclosure Design, employing Dual Eight inch woofer system, surpasses bass and mid-range performance of finest conventional 12 and 15 inch systems. Satin smooth highs are added by specially designed Super Tweeter.

Beautiful modern cabinet styling . . . precision constructed of carefully selected veneers . . . hand rubbed to a lustrous enduring finish . . .

New . . . Diminutive 2-Way Speaker System

THE PERMOFLUX

Diminuette

Exclusive New Design . . . combines full high fidelity performance with minimum cabinet size and low cost. Angled speaker mounting assures correct distribution of sound regardless of placement. Perfect for Binaural when used in pairs.



Two Royal 6 inch
Speakers and Super Tweeter
housed in choice of Mahogany or
Blonde enclosure.

See your Hi-Fi dealer for demonstration; also hear the
New Super Royal Speaker (8, 12 and 15 inch sizes).

For complete descriptive literature write to . . .

Permoflux CORPORATION

4918 West Grand Avenue • Chicago 39, Illinois

West Coast Plant

4101 San Fernando Road • Glendale 4, California



QUIETROLE
 TRADE MARK REG. U.S. PAT. OFF.
ELIMINATES NOISE
THE SAFE-CLEAN WAY!

**"The ORIGINAL
 NON-INFLAMMABLE
 NON-CONDUCTIVE
 LUBRICANT CLEANER"**

Available in
 2 oz., 4 oz., 8 oz.



QUIETROLE . . . the original and most reliable lubricant cleaner quiets noisy television and radio controls, switches* and other moving parts. Why take less . . . avoid imitations . . . order QUIETROLE, developed after years of research.

**NO GUM! NO GOO!
 NO GRIME!**

Carried by recognized jobbers . . . everywhere!

*Unequaled for TV front end switches. Contains no "thinner".



manufactured by
**QUIETROLE
 COMPANY**
 Spartanburg, South Carolina

moved from 6.110 to 6.209 where is heard at fair strength with French to 1700, then in Arabic to 1900 closedown. (Mercier, France)

Thailand—HSK9, 11.6752, measured noted in native 0800-0900 (sometimes to 0920). In letter, lists General Overseas Service 0500-0715, Home Service 0800-0900, and North American Service 2315-0015, all over HSK9, 11.670; wants reports from overseas listeners with suggestions or comments, and says each correct report will be promptly verified by QSL card; return postage is not required; QRA is The Overseas Broadcasting Division, Public Relations Department, Bangkok, Thailand. (Ferguson, N. C.) Noted closing 0715 with announcements in Thai, *English*. (Bishop, Ohio, others)

Uruguay—*El Espectador*, 11.835, Montevideo, is usually heard 1800-2000 at fair to good level but with QRN. (Gay, Calif.) SODRE, Montevideo, is scheduled 0700-1630 on 6.125, 9.620, 11.900; 1630-1915 m.w. only, CX26, 1058 kc.; 1915-2200, 6.125, 11.900. (WRH) CXA10, 11.900, noted at excellent level 1830-1900. (Jensen, Wisc.) CXA13, 6.156, Montevideo, *Radio Carve*, has news in Spanish 2000. (Catch, England)

USI (Indonesia)—Two new transmitters are YDR2, Ternate, Moluccas, 2.446, which relays YDR 0330-0930, and YDN2, Koteradja, Sumatra, 4.985, 1 kw., scheduled 0525-1130. (Cushen, N. Z.) Djakarta's YDF6, 9.71, has been poor lately when opens *English* session 0930 but is good by end of *English* 1030, when continues in Hindi. (Gay, Calif.) Djakarta has *English* 0600-0700, 0930-1030 over YDB2, 4.910, YDF6, 9.710; French 1030-1130, 7.270; Arabic 1115, French 1200, Dutch 1300, *English* 1400-1500, on YDF2, 11.785, YDF6, 9.710. (ISWC, London) If not found on 11.785, try 11.770, which may be used instead.

USSR—*Radio Tashkent*, 6.825, now has *English* 0700-0730, 1000-1030; asks for reports. (Wada, Japan) Moscow is now using a new channel of 6.07 to West Coast with *English* 0100-0200 sign-off, strong level. Is noted to China on new channel of 5.96, strong; 6.07 strong, 6.055 fair, 9.545 good, 7.26 fair, signing off 1000; the Home Service on 9.38, 9.56, 7.15, 6.11, 5.94, 5.02, 7.15 is best around 0500. (Balbi, Calif.) Moscow noted opening *English* session to North America 1820 on announced 15.33, 15.23, 15.11, 11.91, 11.84, 11.81, 11.76, 11.74, 11.71, 9.83, 9.67, 9.62, 9.61, 9.59, 9.55, 9.48 (some of these are actually satellite country relays). (Parsons, Va.) Tiflis, 5.040, Georgia, noted 1315 with orchestral music and vocals, fair level but poorly modulated. (Catch, England)

Vatican—HVJ, 11.74, noted with *English* 1315-1330. (Golden, Mass.; Parsons, Pa.) Noted on 9.645 at 1500 with interval signal, with Paris on same channel; when Paris left air a few moments later, HVJ was fairly in the clear with Portuguese session. (Bellington, N. Y.) Heard with news 1000 over 11.686A. (Roberts, Conn.)

Yugoslavia—Belgrade has been moving back and forth between 9.505 and 9.618A for news 0115-0130 parallel 6.100; noted with news 1645-1700 on 7.200, 6.100. (Pearce, England) Fair on 6.100 with news 1645. (Thompson, Mass.; Hill, Fla.)

* * *

Press Time Flashes

TFJ, 15.175, Reykjavik, Iceland, is noted again Sun. 1115-1130 with news in Icelandic by man. (Cox, Dela.)

When this was compiled, Kol-Zion Lagolah, "The Voice of Zion," P.O. Box 754, Jerusalem, Israel, was starting a series of tests over a period of several weeks, first on 7.190 and later on 9.745, in parallel with 9.009A, from Tel Aviv; it is presumed the tests were to be over the long-projected 50 kw. transmitter; reception reports, including comparison with the 9.009A outlet, are desired. By this time may be on regular schedule over 7.190 and/or 9.745.

Radio Athens, Greece, is scheduled on 9.607, 0215-0800; 7.300, 0830-0915, 1000-1100, 1130-1145; 11.718, 1200-1300, 1330-1415. (Radio Sweden) However, at press time, Mercier, France, flashed that Athens is back on 9.607 with news in French 1230, in *English* 1245.

Mercier, France, says *Radio Cayenne*, French Guiana, has shifted to 6.205 from 6.198A and is heard regularly at poor level 1745-1830 closedown; woman who reads news in French at 1800 is station manager.

Radio Belize, British Honduras, 3.300, is now on winter schedule of 1130-1330, 1830-2130; news in *English* 1930, in Spanish 1940; for last period uses also 4.950. (West, Va.) Revised winter schedule for *Radio Japan* is to West Coast of North America 0000-0100, JOA3, 9.695, JOB2, 7.180; to Hawaii 0200-0300, JOA3, 9.695, JOB6, 11.725; to North and Central China 0600-0800, JOA3, 9.695, JOB2, 7.180; to Philippines-Indonesia 0830-0930, JOA3, 9.695, JOB6, 11.725; to Indo-China, Thailand, Burma 0945-1045, JOA3, 9.695, JOB2, 7.180; to India-Pakistan 1100-1200, JOA3, 9.695, JOB6, 11.725; to Europe 1400-1500, JOA, 6.069, JOB2, 7.180; to South America 1700-1800, JOA3, 9.695, JOB6, 11.725. (Gay, Calif.; Wada, Japan)

New QRA for the American agent for *World Radio Handbook* is Ben E. Wilbur, 47 Mounthaven Drive, Livingston, N. J.; by this time, the 1954 Edition should be available direct from Mr. Wilbur. The European transmissions of "Australian DX-ers Calling" on Sun. is now at 0300 over 9.58, 11.76, 15.32. (Pearce, England) Damascus, Syria, will soon have transmissions to North America and Germany. (Scheiner, N. J.)

Radio Brazil Central, Goiania, Brazil, is on the air over 4.995 at 0600-1730, 1800-2100; Sun. 2100-2130 has "World at Your Home" (news in *English*, Spanish, Portuguese). "Brazil Calling" (*English*) session from Recife, 9.565, Brazil, should now be 1905-1925. (WRH) *Radio Sofia*, Bulgaria, now uses 7.255 in parallel with 7.671

RADIO & TELEVISION NEWS

NEWARK

VALUES • SPECIAL BUYS
for '54

- RCA WV-97A. Senior Voltohmmyst. 62F000. Shpg. wt., 10 lbs. 67.50
- RCA WV-77A. Junior Voltohmmyst. 62F010. Shpg. wt., 6 lbs. 47.50
- Triplett 666-HH. Volt-ohm-milliammeter. 62F208. Shpg. wt., 3 lbs. 24.01
- Triplett 630. Volt-ohm-milliammeter. 62F212. Shpg. wt., 4 1/2 lbs. 38.71
- Simpson 260. Set Tester (Roll Top). 62F303. Shpg. wt., 9 lbs. 45.96
- Simpson 260. Set Tester (Open Face). 62F300. Shpg. wt., 5 lbs. 38.17
- Millen 90651. Popular Grid Dip Meter. 97F208. Shpg. wt., 3 1/2 lbs. 61.50
- Hallcrafters S38C. All-wave Receiver. 98F005. Shpg. wt., 14 lbs. 59.95
- Hallcrafters S40B. Communications Receiver. Covers 540 kc to 43 mc. 98F003. Shpg. wt., 33 lbs. 129.95
- National SW-54. Superhet Communications Receiver. Covers 540 kc to 30 mc. 98F318. Shpg. wt., 10 lbs. 59.95
- National NC-88. New Communications Receiver. Covers 540 kc to 40 mc. 98F312. Shpg. wt., 30 lbs. 129.95
- Newark Portable 3-Spd Record Changer. 73F910. Shpg. wt., 47.50
- Newark Portable 3-Speed Phonograph. 73F903. Shpg. wt., 9 lbs. 22.50
- Dorset. High Fidelity Portable 3-Spd Record Changer with Garrard RC-80. 73F605. Shpg. wt., 30 lbs. 129.50
- Garrard RC-80. 3-Speed Record Changer. 73F510. Shpg. wt., 18 lbs. 45.08
- Wilcox Gay 3A10. 2-Spd Tape Recorder. 75F003. Shpg. wt., 26 lbs. 119.97
- Pentron 9T3C. 2-Track, 2-Spd Recorder. 74F908. Shpg. wt., 27 lbs. 139.50
- Eicor 230. Two-Speed Tape Recorder. 74F940. Shpg. wt., 30 lbs. 127.46
- Espey 512C. FM-AM Tuner Chassis. 96F031. Shpg. wt., 16 lbs. 69.50
- Brush Mike. Hi-Z. At Special Price. 54G350. Shpg. wt., 1 1/2 lbs. 5.95
- Wireless Mike. With built-in midget transmitter. Plays thru any radio within 50 feet. No wiring required. 27F576. Shpg. wt., 3 lbs. 6.50
- Drake 905. Popular Soldering Gun. 33F056. Shpg. wt., 4 lbs. 11.02
- Weller S-500. Heavy Duty Solder Gun. 33F128. Shpg. wt., 3 3/4 lbs. 9.75
- P.E.T. 625L. "Zephyr" Electric Hand Saw. 33F521. Shpg. wt., 11 1/2 lbs. 31.97
- P.E.T. 77DK. Deluxe Electric Drill Kit. 33F503. Shpg. wt., 10 lbs. 18.40
- Casco G-25. "Electromatic" Drill Kit. 33F530. Shpg. wt., 3 1/2 lbs. 12.97

Order from Dept. R-1
FOB Chicago,

Include Insurance and Shipping Charges

For Complete Description
on These and Thousands of
Other Items

Send for
NEWARK'S NEW
CATALOG NO. 56



NEWARK

ELECTRIC COMPANY

223 W. MADISON STREET
CHICAGO 6, ILLINOIS

for "evening" beam to Europe, with French 1545-1615, English 1615-1645. (Mercier, France)

Acknowledgement

Thanks for the fine cooperation during 1953, and may 1954 bring you much SWBC DX. Sorry that space does not permit the use of all reports received, but please continue to send your best items to Kenneth R. Boord, 948 Stewartstown Road, Morgantown, West Virginia, USA.

K. R. B.

"THIS IS W4SKE . . ."

HAMS in New England and the Atlantic states who have heard this call since last September 23rd are probably unaware that it comes from Room 136 of the Institute of Physical Medicine and Rehabilitation of New York University-Bellevue Medical Center where Dick Phillips, 18-year-old bulbar polio quadriplegic, carries on his QSO's from a special motorized hospital bed.

Dick, who was stricken in September, 1952, has learned to "frog breathe" by forcing air into his lungs with his tongue and throat and neck muscles. This results in hardly noticeable interruption in his speaking pattern while QSO-ing.

Today, Dick operates a Hallcrafters HT-20 transmitter and a S-40 receiver from his bed. Hams in "W4 land," civic leaders, and newspapers in his home state of Kentucky raised the necessary funds to buy transmitting equipment for him. Dr. F. E. Hunt, a fellow ham at the Institute, rigged a 135-foot doublet on the hospital roof.

Dick operates mostly on the 75-meter band and has QSO'd not only with hams in the New York area but also talks to his parents weekly through a ham in Louisville with a phone-patch attachment. Atmospherics and interference from the electrical equipment in the hospital slowed him down at first but he hopes to whip this problem.

He is already planning a career in the radio-communications field and with the treatment and training he is receiving with March of Dimes funds, it is a pretty safe bet that Dick will make it 100 percent!

Dick operates his Hallcrafters HT-20 transmitter and S-40 receiver while Dr. F. E. Hunt, a fellow ham, shows the log of W4SKE to Jack Halligan of Hallcrafters.



BIG TALK about small rotary switches

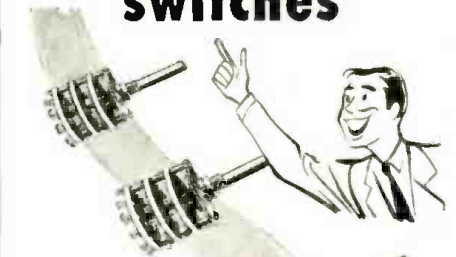

And why not?

These Centralab miniature switches give you new, small size . . . new flexibility . . . new protection. They carry the same ratings as the larger 2500 series switches plus excellent r.f. characteristics.

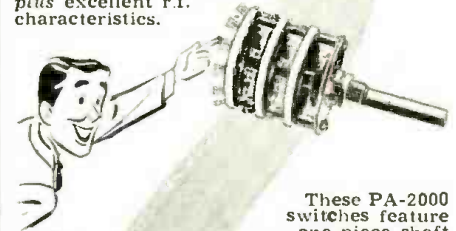

These PA-2000 switches feature one piece shaft construction for more accurate indexing. You can buy them with one to six sections per shaft—12 active positions per section. Sections are famous Centralab Steatite, in either shorting or non-shorting arrangements. Tests prove they can't be beat for dependability!

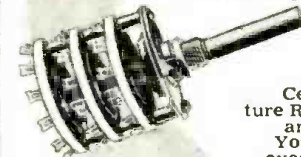
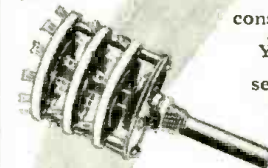

See your Centralab distributor and insist on Centralab Miniature Rotary Switches and Switch Kits. You'll always get exact replacement you want for guaranteed servicing.



BUY 'EM AS COMPLETE SWITCHES OR SEPARATE ASSEMBLIES. STEATITE SECTIONS, INDEXES, HARDWARE AND ACCESSORIES ALWAYS AVAILABLE.

Centralab

CENTRALAB,
A Division of Globe-Union Inc.
910-A E. Keefe Ave., Milwaukee 1, Wis.
Please send me technical data on Centralab Miniature Rotary Switches and Kits.

Name.....
Firm.....
Address.....
City.....Zone.....State.....

These outstanding
SHURE
PICKUP CARTRIDGES
provide maximum fidelity
of RCA 45 r.p.m.
records

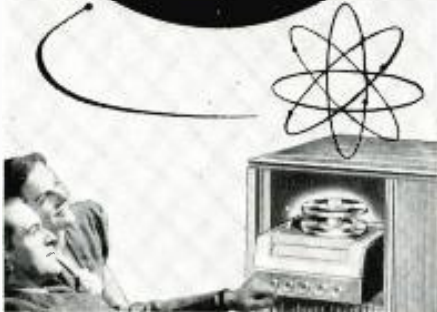

"DIRECT DRIVE" CRYSTAL (W31AR)
High output (2.1 volts!) "Direct Drive" cartridge specifically designed for use with all fine-groove records. Universal mounting bracket provides quick, easy installation in RCA-type 45 r.p.m. changers. (Fits 1/2" and 3/8" mounting centers.) Has easy-to-replace needle. For maximum quality, highest output, and low cost, specify Model W31AR at the low list price of only \$6.50.



"DIRECT DRIVE" CERAMIC (WC31AR)
Same as Model W31AR, except for ceramic element and .65 volts output. Highly recommended in areas where heat and humidity make use of conventional crystal cartridges impractical. List price.....\$6.50



"VERTICAL DRIVE" (W21F)* High-fidelity cartridge. Provides superlative reproduction for 33 1/3 and 45 r.p.m. records. Extended frequency response (50 to 10,000 c.p.s.). Low tracking pressure (only 6 grams) and high needle compliance guarantee faithful tracking and longer record life. Uses quiet tracking Shure "Muted Stylus" needle, scientifically designed for maximum performance and long life. List price.....\$7.75



*Cartridge with .453 Mount for Oak Changer

SHURE BROTHERS, Inc.

Microphones and Acoustic Devices
225 W. HURON ST. • CHICAGO 10, ILLINOIS
Cable Address: SHUREMICRO

Spot Radio News
(Continued from page 18)

clared that . . . "one or more stations in fifty-seven cities have already placed orders . . . for color broadcast equipment." Items ordered include cameras for live broadcasts, slide and film equipment, and color monitors and terminal apparatus.

AN INTERESTING ESTIMATE of the number of sets that might be made during the next three years appeared in a review of the color situation by a manufacturer of metal parts for picture tubes. He felt that the original prediction of 50,000 for '54 was sound, but that in '55, there would be 800,000 color sets made, and in '56 this would be doubled, while in '57, close to 3,500,000 compatible-color sets would come off the production line.

THE FEAR that the proposed color systems of Otto Luther, and Marshall Soghoian and S. L. Cooke, Jr., would disturb the present NTSC picture evaporated when the Commission declared that at present these systems are merely blueprint items, and therefore the proponents have not met the requirements set forth; representative receivers were not delivered to the Commission's lab, nor has a signal employing the proposed transmission specs been put on the air either in Washington or any other locality.

Irked by the Commission's statement, Soghoian sent a letter to several hundred newspapers throughout the country, charging that adoption of the compatible color system would give one company a monopoly, since most of the engineers on the NTSC panels were working for companies who were licensees of that company, and in addition, only this company had developed workable tricolor tubes and receivers. In addition, it was charged that the new standards do not permit practical conversion of present sets to color, and this it was said would . . . "saddle the public with an unnecessarily high cost television system." Letters were also sent to members of Congress, specifically those on the Senate Interstate Commerce Committee.

At this moment, it does not appear as if there will be any Congressional action on this objection, in view of the deadline statement made by the Commission, the costly tests held and extensive plans made by industry, plus the general consensus among Congressmen and the Commission, too, that the NTSC system is the answer.

Pressure to hold up color approval until Christmas appeared in the form of a bold letter from the chairman of NARDA's government relation committee, Mort Farr, to Rosel Hyde. Said Farr: "The day your decision is made and published by newspapers, we can expect a marked decline for black and white sets in many, if not

ATLAS PROJECTORS

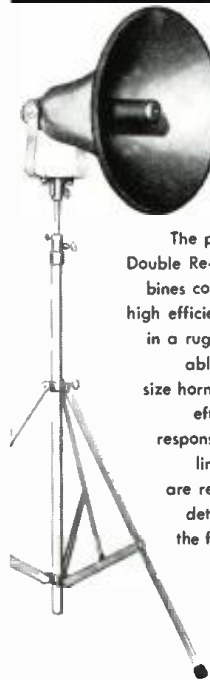

9 models to choose from for EVERY application

The performance-proved ATLAS Double Re-enlrant ("DR") design combines compactness with unequalled high efficiency and uniform response in a rugged, stormproof, demountable construction. The larger size horns are excellent for greatest efficiency and low-frequency response. Where space and cost limits exist, the smaller horns are recommended. For complete details on "DR" Projectors and the famous ATLAS line of Public Address and Microphone Stand equipment . . .

WRITE NOW for FREE Catalog 553

ATLAS SOUND CORP.
1446 39th St., Brooklyn 18, N. Y.
In Canada: Atlas Radio Corp., Ltd., Toronto, Ont.

New Guaranteed **TUBES** Standard Brands

0A2	\$0.90	4E27	14.50	804	10.95
0A3	1.10	4-125A	22.50	805	3.75
0A4	1.00	4X150A	27.50	807	1.85
0B2	1.10	58P1	4.50	811A	2.90
0C1/VR105	.95	6X22	37.50	812	3.50
0D1/VR150	.85	6FP7	1.95	813	10.95
1A3	1.00	5R4GY	1.25	814	2.95
1B22	2.00	6AK5	1.95	829	5.95
1B23	1.45	6AL5W	1.75	818	2.75
1B24	2.50	6AN5	2.95	812A	9.50
1B27	12.50	6AS7G	3.50	813A	29.50
1N21B	2.40	6K4	3.50	835	3.50
1N22	1.25	15E	1.75	837	1.45
1N23	1.25	15E7	14.95	868	1.40
1N24	3.25	16K50/1641	2.25	868A	1.40
1N34A	.75	VT 127A	2.95	872A	2.75
1N38	1.50	1007H	1.50	874	1.10
1N48A	3.25	250TH	16.90	884	1.40
1N43	2.15	304TL	7.95	811A	8.50
1N69	2.65	307A	8.95	955	3.3
1N78	2.50	6X4	3.95	954	1.40
2C39	12.50	94A	3.95	955	1.40
2C40	8.50	417A	8.50	957	1.40
2D1	4.25	448A	8.50	957A	1.40
2D21	1.25	450TL	44.00	959	1.95
2E22	2.75			991	1.30
2E23	2.25			1005	1.30
2E25A	4.50			CK1006	2.75
2K22	22.50			1615	1.40
2K23	28.50	80-18	57.80	1616	1.30
2K24	28.50	80-22	12.50	1626	1.30
2K41	125.00	12-32	10.00	2091	1.10
2L10	21.00	100-20	14.50	8879	3.50
2K48	99.50			2702	2.75
3A4	7.75	703A	4.50	2703	2.95
3A5	1.25	705A	1.50	2704	2.25
3B2A	3.50	707B	13.95	2704A	2.25
3C22	72.50	715H	14.50	2706	2.00
3C24	24.00	715C	2.75	2706A	1.75
3C33	12.50	717A	.90	2844	4.50
3C45	12.50	723A	18.95	2844	4.50
3E21	11.95	724B	2.75	8012	1.95
3FP7	1.95	726A	12.00	8020	1.25
3GP1	3.95	726H	35.00	8029A	1.25
3HP7	1.95	726C	59.80	9001	1.25
4C27	12.50	802	2.95	9002	.98
4C35	19.50	803	3.95	9003	1.50

Complete line of Receiving Tubes. Thousands of other types of Transmitting Tubes. If you don't see it, WRITE. Prices subject to change without notice. Californians add sales tax. Add postage to order. Minimum order—\$3.00.

VEEDER ROOT COUNTER

5 figure. Adds ten for each revolution of shaft in one direction; subtracts ten for each revolution in opposite direction. Size 3/4"x3/4"x1" dovetail mounting; lever arm removable.



ONLY 1.25 ea.
Quantity Discounts

jsh SALES CO.
ELECTRONICS
Dept. R-28
7552 Melrose Ave.
Los Angeles 46, California

most, of our principal markets; no matter how ably we present facts about higher cost, smaller images, limited availability, and few programs. The effect could mean a sharp decline in employment and serious economic problems. Traditionally, we sell 36 per-cent of the year's volume during the fourth quarter of the year. . . . If your decision were announced December 24, unemployment in our industry based on the advent of color would be minimized, the economic penalty of the announcement from (probably) the manufacturers' and distributors', and certainly from the dealers' viewpoint would be minimized, and the start of color would in no way be delayed. . . . On behalf of the membership of the National Appliance and Radio-TV Dealers' Association, I urge you to release the announcement of your approval of the National Television Systems Committee color television system as close to Christmas, 1953, as circumstances permit."

As this column was being written, it seems as if NARDA's plea will bear fruit, for it is generally believed that the OK for compatible color will be announced around the Yuletide.

AS INDUSTRY set up its pilot model benches for color, broadcasters began experimenting with local and trans-continental colorcasts. For the first time in TV history, a group of local advertisers were able to see a demonstration of their own products on color TV, when WPTZ, Philadelphia, held a special demonstration. The video portion of the program originated from the research lab of Philco, four miles away, with the distance spanned by a microwave relay.

In Los Angeles, hundreds saw a coast-to-coast color show, presented by NBC and RCA, featuring a live-film half-hour program from the Colonial Theatre, similar in part to that shown to the Commission in New York City. A 4000-mile closed radio-relay circuit brought the color signals to the Pacific coast. Highlight of the test was the filmcast using a 16 mm fast pulldown projector with a flying-spot scanner tube. During a special demonstration of the projector before a group of consultants in Camden, it was pointed out that the term *fast* was used to describe the projector, since the scanner moves the film from a standstill position to a speed of some 22 miles-per-hour and stops it again, all in a bit more than one one-thousandth of a second. Actually, in operation, each frame of the film remains stationary in a projector gate while the beam on the flying spot tube scans a complete raster. This method of scanning is very satisfactory, it was said, because the three signals obtained from the photocells, which correspond to the three primary colors, are automatically in register. It was noted, though, that the system has a drawback; the force necessary to start and stop the film so quickly does place a severe strain on the film. Thus only

FOR THOSE WHO SEEK THE ULTIMATE IN HIGH FIDELITY CABINETS

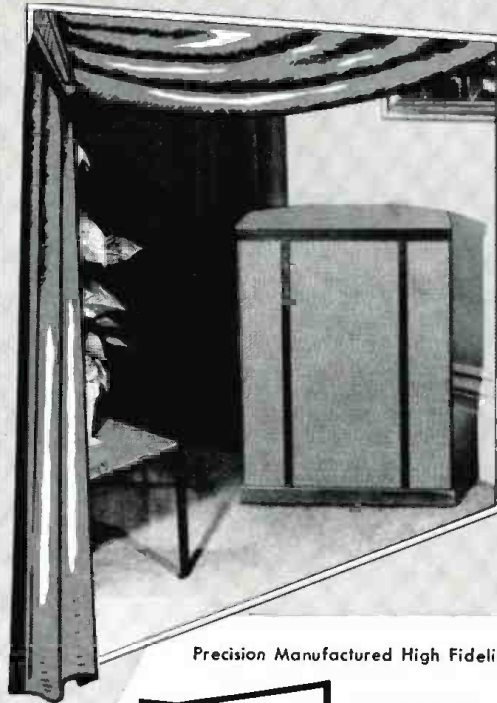

Klipsch REBEL IV by Cabinart

A Klipsch Corner Horn Enclosure designed especially for manufacture by Cabinart.

- Two-way system performance. So flexible in design so as to provide you wide latitude in determining your listening requirements. Removable panel allows for a variety of speaker combinations. For example, in the 12" Klipsch you can install a single 12", two 12" speakers or a tweeter-woofer combination.

- Attractively styled to blend with any interior decor, the Klipsch Rebel IV by Cabinart comes in Lined Oak, Honey Walnut, French Mahogany and Black Lacquer.

"Popularly Priced"

*\$69.00 Net for 12" model

*\$87.00 Net for 15" model

**Net prices, slightly higher West and South.*

Precision Manufactured High Fidelity Cabinets of Character



G & H WOOD PRODUCTS CO.

75 NORTH 11th STREET, BROOKLYN 11, N. Y.

Pioneers in radio furniture for high fidelity equipment

Concord Catalog



It's Got **EVERYTHING**

- STANDARD Lines.
- Special Buys

FREE!

FREE!



Sensational SELF POWERED 2 WAY PHONE SYSTEM

\$4.87 per Set

A MUST FOR EVERY SERVICEMAN or MECHANIC

Extremely sensitive 2 way phone system will operate with telephone like clarity over distances of up to one mile. Phones made of rugged, shockproof Dow Styron with self-contained 1½ Volt flashlight battery. Battery life approx. one year. Has full size carbon mike and Alnico 5 earphone magnet. All metal parts 24 carat gold plated. Complete with push to talk switch, spring clip-leads and wall brackets. Uses regular two-conductor twisted pair. Without a doubt, one of the most sensational service, office or home items ever offered. Complete with batteries.

Two conductor twisted pair weatherproof wire for above . . . 2¢ per ft. 100 ft. \$1.50

CONCORD RADIO, 53 Vesey St., N. Y. 7 Dept. N41

- Please send . . . sets of phones at \$4.87 ea.
- Enclosed find \$. . . in complete payment. Minimum 20% deposit with C.O.D.
- Send new 1954 CONCORD CATALOG!

NAME _____

ADDRESS _____

CITY _____ ZONE _____ STATE _____

Concord Radio

55 Vesey Street, New York 7, N. Y.

Phone DLgby 9-1132

WESTON METERS

Model 301, RECTIFIER TYPE
0-150 Volts AC, 1000 ohms per volt AC, \$9.95 Ea.
Round bakelite case 10 for \$89.95
NEW! BOXED 10 for \$89.95

OTHER WESTON MODEL 301—

0-200 Microamps DC \$9.95
0-10 Volts DC (1000 ohms/v) 7.95
0-1Ma (KV Scale) 7.95
0-50 Ma DC 7.95
0-15 Volts AC 7.95
0-1 Amp DC 7.95
0-1.5 Mills DC 7.95

MODEL 731

0-200 Microamps (Spec. Scale) 9.95
0-1 Ma (0-100 Scale) 8.95

MODEL 506

0-200 Microamps 7.95
0-1 KV with Mult. 7.95

WESTERN ELECTRIC METERS

3 1/2 inch round

100-0-100 Microamps DC 8.95
0-1.5 Ma DC 5.95

WESTINGHOUSE METERS—Model NX35

0-500 Microamps (0-100 Scale) 6.95

GENERAL ELECTRIC

0-150 Volt AC—Model AO 22 7.95
0-3 Amp RF w/Thermo—Model D044 7.95
0-5 Amp RF AC Thermo—Model D044 7.95
Running Time, 99,999 Hours, 115 V., 60 cy. 10.95

UTC COMMERCIAL GRADE TRANSFORMERS

Type CG, Fully cased, Hermetically sealed, Primary 115 V, 60 Cy, Tapped from 105 Volts in 6 steps, Secondary 750-0-750V., 325 MA Continuous duty rating. BRAND NEW \$9.95 Ea.
Type CG Choke to match, 12 Henry, 325 MA. BRAND NEW. \$4.95 Ea.

G. E. RELAY CONTROL

(Ideal for Model Controls, Etc.)

Contains a sigma midgot 8,000 ohm relay (trips at less than 2 MA), High impedance choke, bi-metal strip, neon pilot and many useful parts. The sensitive relay alone is worth much more than the total low price of . . . \$1.25 Each 10 for \$9.90

Panel Meters

NEW GOVT SURPLUS STANDARD BRANDS 2" METERS
DB meter—10 to +20 \$3.49
0-500 ma DC 3.49
3" METERS
0-200 Microamps \$8.95
0-400 Microamps 5.95
0-500 Microamps 5.95
0-200 Millilamp 4.50
0-1000 Millilamp 4.50
0-1.5 Volts AC 4.95
0-3 Volts AC 4.95
4" METERS
0-200 Microamps \$8.95

OIL CONDENSERS

4 MFD-600 VDC \$0.95
10 MFD-600 VDC 1.75
12 MFD-1000 VDC .95
6 MFD-1500 VDC 2.95
8 MFD-1500 VDC 3.50
2 MFD-2000 VDC 2.50
4 MFD-2000 VDC 3.50
10 MFD-2000 VDC 5.50
2 MFD-2500 VDC 3.95
2 MFD-4000 VDC 3.50
3 MFD-4000 VDC 5.95
1 MFD-5000 VDC 3.95
2 MFD-5000 VDC 5.95
50 MFD-350 VAC 6.95
.1 mfd 7500VDC . . 1.75
1 12KVDC 2.95
15 MFD 2 KVDC 49.95
5 mfd 660 VAC 2.95

NON-INDUCTIVE RESISTORS

Ohmite, 250 Ohm, 100 Watt. \$59¢
Special, 5 for \$2.50

ACME PLATE TRANSFORMER

Pri. 220V, 50/60 Cy, 3 Phase, Delta Connected. Secondary 3 phase, Y connected, 2622 Volts @ 7.5 KVA \$99.50

RAYTHEON PLATE TRANSFORMER

Pri. 220V single phase, tapped, 80 cycle. Secondary. 6000 Volts to 8000 Volts @ 1 Amp in 400 Volt steps \$99.50

SOLA CONSTANT VOLT TRANSFORMERS

Input 95-125 V 60 Cy Output Regulated 115V
250 VA \$33.85
500 VA 48.65
1 KVA 79.95

MOBILE DYNAMOTORS

6 Volts input, 425 Volts at 375 MA Output. 6 3/4" Long. 4" Diameter. Weight 10 lbs. List Price Ap. prof. \$70.00
BRAND NEW ONLY \$24.95

CARTER SUPER DYNAMOTOR

12V Input, 400V Output @ 200 MA \$24.95
CONTINENTAL DYNAMOTOR
11V Input, 475V @ 210 MA Output \$19.95

WIRE WOUND RESISTORS

Stock too long to list. We can supply most sizes, so order what you need.
10 Watts, From 1 Ohm to 70K Ohms. Ea. \$.13
20 Watts, From 4 Ohms to 50K Ohms. Ea. .20
25 Watts, From 1 Ohm to 100K Ohms. Ea. .30
50 Watts, From 5 Ohms to 100K Ohms. Ea. .40
100 Watts, From 50 Ohms to 100K Ohms. Ea. .50
ADJUSTABLE SLIDER, WIRE WOUND
10 Watts from 1 Ohm to 10K \$.25
25 Watts from 20 Ohms to 2.5K35

EIMAC VACUUM CONDENSERS

6 MMF 32 KVDC (VC 6-32) \$ 9.95
12 MMF 32 KVDC (VC 12-32) 10.95
25 MMF 32 KVDC (VC 25-32) 11.95
50 MMF 32 KVDC (VC 50-32) 12.95
100 MMF 20 KVDC Jennings 12.95
100 MMF 5 KVDC G.E. 4.95

Min. Order \$3.00—25% with Order

PEAK ELECTRONICS CO.
66 West Broadway, New York 7, N. Y.
Phone WOrth 2-5439

16 mm film can be used. One solution to the problem lies in the use of three Vidicon camera tubes, which can simultaneously scan the film as it is run through a separate projector; in this instance the film can be 16 or 35 mm. Under this scheme, the colors can be separated via dichroic mirrors, which deliver the correct color to the proper tube.

FM once again is losing its fight for a firm position in broadcasting, and unless something is done, the 88-108 mc. band may find itself in jeopardy. Thus warned Commissioner E. M. Webster during a talk before broadcasters in Sun Valley, Idaho and in a letter to Ben Strouse, chairman of the FM committee of the National Association of Radio and Television Broadcasters.

Unless the broadcasters increase the use of the FM channels, the Commissioner added, he would have . . . "difficulty in finding it in the public interest to retain all of the . . . band . . . for FM broadcasting . . . in the event the Commission is petitioned to re-allocate a portion of that band to

accommodate new or existing services." In his opinion, the weakness of FM lies . . . "in its lack of nationwide coverage by FM stations rendering programs which are not a duplication of their respective AM affiliates."

Addressing Strouse, Commissioner Webster said that he felt that both the Commission and industry were at fault for the retarded progress of FM, since both have allowed AM to expand its coverage to a point where FM could not compete. A partial remedy does exist, he added, in the relaxation of rules governing FM broadcast service, reducing the minimum hours of operation, permitting low-power stations, and such services as functional music and multiplexing.

The gradual decline of FM is quite evident in the station listings. On June 30 of last year, there were 582 licensed FM stations on the air; on June 30 of this year, there were only 551. In contrast, there has been no reduction in the number of AM stations, but a steady gain. A year ago there were 2420 authorized stations. Last June, the records showed that 2584 were broadcasting on AM, and

NEW TV GRANTS SINCE FREEZE LIFT

Continuing the listing of construction permits granted by FCC since lifting of freeze. Additional stations will be carried next month.

STATE	CITY	CALL**	CHANNEL	FREQUENCY (mc)	POWER* (Video)
California	Corona	KOWL	52	698-704	38
"	Merced	KMER	34	590-596	17.8
Connecticut	Hartford		18	494-500	210
Delaware	Wilmington	WILM-TV	83	884-890	13.2
Florida	Orlando	WDBO-TV	6	82-88	100
Georgia	Augusta	WRDW-TV	12	204-210	102
"	Augusta	WJBF-TV	6	82-88	23.4
Indiana	Terre Haute	WTHI-TV	10	192-198	316
Iowa	Mason City	KGLO-TV	3	60-66	100
Kentucky	Paducah		43	644-650	17.4
Louisiana	Lafayette	KVOL-TV	10	192-198	55
"	Lafayette	KLFY-TV	10	192-198	55
"	Shreveport	KSLA	12	204-210	30.9
Missouri	Cape Girardeau	KFVS-TV	12	204-210	316
North Carolina	Saldsboro		34	590-596	17.8
Oregon	Golds	KSLM†	3	60-66	5.5
Pennsylvania	Erie		35	596-612	66
"	Philadelphia	WIBG-TV	23	524-530	1000
South Carolina	Aiken	WAKN-TV	54	710-716	17.4
"	Anderson	WAIM-TV	40	626-632	135
Washington	Vancouver	KVAN-TV	21	512-518	107
Wisconsin	LaCrosse	WKBH†	8	180-186	100
"	Superior	WDSM-TV	6	82-88	100

NEW CALL LETTER ASSIGNMENTS

California	Fresno	KCAF	53	704-710
"	Sacramento	KCCC-TV	40	626-632
Illinois	Evanson	WTLE	32	578-584
"	Joliet	WJOL-TV	48	674-680
Iowa	Cedar Rapids	KEYC	20	506-512
Massachusetts	Boston	WJDW	44	650-656
"	Brockton	WHEE-TV	62	758-764
"	Worcester	WAAB-TV	20	506-512
Michigan	Bay City	WNEM-TV	5	76-82
Mississippi	Jackson	WJDT	3	60-66
"	Meridian	WTKR-TV	11	198-204
New Jersey	Trenton	WTTM-TV	41	632-638
Pennsylvania	Allentown	WFMZ-TV	67	788-794
Tennessee	Knoxville	WROL-TV	6	82-88
West Virginia	Wheeling	WTRF-TV	7	174-180

*ERP = (effective radiated power, kw.) . . . = Call letters to be announced
† = Temporary call letters.

COMMUNICATIONS RECEIVERS



Contains All Components

- FEATURES**
- 6SL7 Phase Inverter
 - P.P. 25LGGT Audio
 - VR-75 Voltage Regulator
 - Full Vision Calibrated Dial
 - Cabinet 19 1/2" long x 10 1/2" high x 12 1/2" deep
 - Finished in fine grain black wrinkle
 - Front panel silk screened to identify each control

Crystal Phasing selectivity and Change switch

complete into the and marked. and you appear 4 times Diagram supplied.

59⁵⁰ KIT PRICE EACH F.O.B. without notice.

component units, 100 ohms connected to **\$1.50**

20 high-impedance. Com-rubber cord. and **\$3.95** each

Y! der. Balance C.O.D.

TRONICS, INC.
Chicago 7, Illinois
TELEVISION SUPPLIES

ING?

BE SURE
O & TELEVISION NEWS
FOLLOWS YOU. PLEASE
SEND YOUR CHANGE
OF ADDRESS TO

Circulation Department
64 E. LAKE ST. CHICAGO 1, ILL.

250 applications for AM grants were still in the file at that time. Only eight FM applications were pending then.

A real spurt in public interest in FM soon was predicted by Strouse in a reply to the Commissioner. He felt that the upswing will be due to the mounting interest in high fidelity and the promotion of hi-fi sets by receiver manufacturers. The possible use of multiplexing, as demonstrated by Major Armstrong recently, permitting simultaneous transmission of two programs within a standard FM band of 200 kc. was also cited as a factor which could spark FM. According to the Major, the system is based on new modulation techniques, in which . . . "one channel is protected from the cross-modulation effects of another . . . and noise effects originating in one channel are prevented from straying across into and adding to the noise level of the other channel." A subcarrier frequency of 27.5 kc. is used and this is frequency modulated by the program of the second channel. Currently, an 8000-cycle modulation range is used on this channel.

Where the two channels are available, the famous inventor explained, binaural recordings could be broadcast from a single control room, offering a much desired type of wide-range broadcasting for the growing family of hi-fi enthusiasts.

TV STATION grants, which it was assumed would become a rush project in the fall, are still moving along slowly. Application withdrawals, competitive arguments, and operational protests have jammed the calendar and made it impossible to speed up authorizations. At present the very-high approvals continue to just about balance those issued for the higher bands, as the table on page 148 illustrates.

AN INTERESTING report on the prospects for fire and police radio services in the future was outlined recently by Edwin L. White, FCC chief of the safety and special radio services bureau, in a talk before the International Municipal Signal Association. He pointed out that at the end of the war, there were 2643 licenses outstanding in the police service. As of the end of last June, this figure had grown to 8005. And as of July 1, there was a total of 1134 fire installations. At present, he added, there are approximately 15,000 fire-fighting organizations which are eligible for fire frequencies. These figures reveal, he noted, that the prospects in radio communications service in the police and fire departments is for greater growth, and a greater number of stations on the available frequencies. This will be true, White emphasized, whether or not the depression, that is always predicted by the gloom merchants, ever hits. Truly, a welcomed forecast by one who really knows. . . .

Engineering

WRITERS

ENGINEERS, E. E. or PHYSICS GRADUATES, for preparation of technical manuals . . .

HUGHES RESEARCH AND DEVELOPMENT LABORATORIES' expanding program for production of radar, electronic digital computers, guided missiles and other military advanced electronic systems and devices requires the following:

- 1 ELECTRICAL ENGINEERING AND PHYSICS GRADUATES** to prepare operating, servicing and overhauling instructions for complex electronic equipment. Those with previous maintenance experience on military equipment preferred. Writers will participate in a three-month training school to become familiar with the latest Hughes equipment prior to writing assignments.
- 2 ENGINEERS EXPERIENCED** in the writing and preparation of maintenance manuals for electronic equipment or guided missiles. These specialists will work step-by-step with the people designing, developing and manufacturing the products involved. Experience in the writing of engineering reports is of value.

HOW TO APPLY

Write full details of your qualifications to

HUGHES

Research and Development Laboratories

SCIENTIFIC AND ENGINEERING STAFF
Culver City, Los Angeles County California

Assurance is required that relocation of the applicant will not cause disruption of an urgent military project.

TRANSVISION FIELD STRENGTH METER

Finest
at
Any Price



For 110V AC,
and BATTERY
OPERATION

**SAVES 50% OF
INSTALLATION COST**

Works from antenna
(no TV set needed)

\$69
NET*

FINEST because: Each Meter is individually calibrated in microvolts on every channel. Widest range—10-50,000 microvolts. 12 channel selector. Multiplier switch for weak signal areas.

Pays for itself on 3 or 4 jobs. Measures relative picture signal strengths directly from antenna. Determines best antenna system and orientation. Checks receiver re-radiation (local oscillator.) Identifies signals—TV, FM, TVI. Easy to operate, light, rugged. Many other exclusive features.

*Model FSM-4, for 110V AC only. Complete with tubes. Wt. 13 lbs. net \$69.

Model FSM-4B, for 110VAC and Battery Operation (case and cables included, batteries extra). Wt. 22 lbs. net \$89.

TRANSVISION, INC.
NEW ROCHELLE, N. Y.

A MUST IN
FRINGE AREAS

**UHF
or
VHF**

10 DAY TRIAL:
Try these fine instruments for 10 DAYS. Then, if you return them, your cost less 10% (our cost of re-packaging) will be refunded.

Test & Repair CRTs

Make BIG PROFITS this EASY way:

Every Service Shop needs these Transvision instruments. Can be used white picture tubes are in sets or cartons. Choice of 4 types:

TESTER-REACTIVATOR-SPARKER: 3 instruments in 1. Measures cathode emission; locates shorts between elements; locates high resistance shorts (leakage) as high as 3 megohms. Gives rapid check of gas condition of tube.

Reactivates dim tubes—removes brightness and detail. Sparks out electrical leakage. . . . net \$34.95

TESTER-REACTIVATOR: 2 instruments in 1. Similar to the above but without the sparking function. . . . net \$19.95

TESTER-SPARKER: 2 instruments in 1. Sparks out electrical leakage between elements—saves many picture tubes and small tubes. Provides a variable 8,000V. hard-to-cure deflection problems. net \$25.95

SPARKER: Eliminates leakage between elements in picture tubes and small tubes. . . . net \$18.95



Transvision, Inc., New Rochelle, N. Y., Dept. N1

- Send me _____
- Enclosed find \$_____ deposit. Balance C.O.D.
- My JOBBER is _____
I accept your 10 Day Trial terms.

Name _____
Address _____
City _____ State _____

JOBBER INQUIRY INVITED

Novice Transmitter (Continued from page 53)

made from light aluminum 11/4" x 3". The edge of a discarded aluminum chassis may be used for this if one is available. Aluminum right angle brackets are secured to the two ends of the sub-chassis so that after assembling the sub-chassis it may be attached inside the transmitter case.

A center line is drawn on the long dimension of the sub-chassis and the crystal socket, two octal tube sockets, and the 5-prong coil socket laid out. Socket holes are now punched for the coil and tubes, while the crystal socket is mounted by reaming 1/4-inch holes large enough to accommodate the crystal socket body.

Turning to the main chassis, the male power connector can be mounted by drawing a center line on the long dimension of the end of the chassis, drilling the required hole to accommodate the socket punch 1 1/2 inches from the bottom and punching the hole out. The coaxial connector or insulated antenna terminal is next mounted on the opposite end of the chassis. A 5/8 inch hole is made 1 1/2 inches from the bottom on the center line of this end. The two variable condensers are mounted on the front of the transmitter case 1 1/2 inches from the bottom of the chassis. The first (C₁) is mounted 1 1/2 inches from the corner of the chassis and the second (C₂) is mounted 4 1/2 inches from the right hand corner. The jacks for the key and the meter are mounted in 3/4 inch holes, 1 1/2 inch from the bottom of the chassis. The first (J₁) is mounted 1 1/2 inches from the left-hand corner and the second (J₂) is mounted 4 1/2 inches from the same corner. As J₂ is in series with the cathode circuit it must be insulated from the chassis with fiber washers.

We are now ready to wire the sub-chassis. Referring to the circuit diagram, Fig. 4, we can find where each component goes in the circuit while Fig. 3 indicates where each part is mounted in physical relation to the others. First, all the resistors are soldered into place, then all the condensers, and finally the r.f. chokes. Although the photograph (Fig. 3) shows the jacks connected into the circuit the jacks should be mounted on the chassis as stated previously and the wires soldered on after the sub-chassis is mounted. When the sub-chassis is completely wired, checked for errors and rechecked for errors, it may be mounted in the transmitter case and the connections to the power plug, antenna terminal, variable condensers, and, as mentioned before, the key and meter jacks, completed.

As the power supply is not critical as to parts layout no specific instructions are necessary. The parts are laid out, locations marked, parts mounted, and the various connections made. A suitable length power cable with fe-



MIDGETS

that
do

a
Gial

Grayburne FERRIS

World's most sensitive small radio antenna

Grayburne VARI

Same as Ferri-Loopable micrometer adjustment

Over 50,000,000 small radio Loopsticks. Replaces inefficient pulls in stations strong formers rave over performance over profits.

CARRY several Loopsticks today from your distributor

SupereX 23 Atherton

Editors and En

RADIO & ELECTRONICS

RADIO HANDBOOK. GIANT 13TH one-volume library of radio information, extensive, simplified theory. Detailed build-it data on dozens of items of radio equipment. Book No. E&E-RH

BETTER TV RECEPTION (in fringe and rural areas). NEW SECOND EDITION. A guide for installation technicians. Text for TV enthusiasts. Book No. E&E-TR2

WORLD'S RADIO TUBES (Brans' Vade 9TH EDITION. Lists over 15,000 tube every tube making country. Printed in languages. Book No. E&E-VM9

WORLD'S EQUIVALENT TUBES (Equip Vade Mecum) NEW 10TH EDITION. A guide to substitutions of radio tubes, indicating or near equivalents. Book No. E&E-VM10

RADIOTELEPHONE LICENSE MANUAL. Typ study questions with concise answers for commercial U.S.A. radiotelephone operators. Book No. E&E-RL1

ANTENNA MANUAL. A practical, comprehensive book on antennas, for everyone interested in transmission and reception. Over 300 pages. Book No. E&E-AM1

SURPLUS RADIO CONVERSION MANUAL. VOL. 1. Practical conversions. Write for list of contents. Book No. E&E-SM1

SURPLUS RADIO CONVERSION MANUAL. VOL. 2. Companion to Volume 1. Book No. E&E-SM2

*Plus any tax.

Send three cent stamp for circular with detailed contents of books listed.

BUY FROM YOUR DISTRIBUTOR
ADD 10% ON DIRECT MAIL ORDERS TO
EDITORS AND ENGINEERS, LTD.
BOX 609A SANTA BARBARA, CALIF.
Bookstore order from PARKS & TAYLOR, Millido, N. J.

RADIO & TELEVISION NEWS

male plug at the end is used to carry the various voltages to the transmitter power connector.

Tuning Operations

We are now ready to tune the transmitter up and put it on the air. For the initial tests a 50 watt incandescent light bulb should be used as a dummy antenna so no unnecessary interference is transmitted. The lamp should be connected between the antenna terminal and ground.

An appropriate crystal is placed in the crystal socket, the tubes and coil placed in their respective sockets, and the power cable connected. The main switch (S_1) on the power supply is turned on, making certain the plate voltage switch (S_2) is in the "off" position. The voltage reducing switch (S_3) is placed in the low voltage position thereby taking C_{12} out of the circuit. The key and meter are plugged into J_1 and J_2 respectively.

After the tubes of the transmitter have warmed up for a half minute or so, turn on the plate voltage switch (S_3). Depress the key and tune C_{10} for a minimum reading on the meter. Then tune C_{11} , which loads the antenna, for maximum reading on the meter. Retune C_{10} for a minimum dip once more.

In order to make certain that the amplifier is tuned to the proper amateur band the output circuit L_1 should be checked with a wavemeter or a grid-dip meter. If an indication is not obtainable in the 80 meter band, C_{10} and C_{11} should be retuned to a different part of the condenser until the proper frequency reading is obtained.

Now connect the antenna terminal, J_3 , to the outdoor antenna (with the plate voltage off, of course). Repeat the tuning procedure as outlined until the maximum current reading is obtained. However, the current should not exceed 215 ma. which is the maximum power input permitted for Novice operation. The final amplifier constitutes 175 ma. of this and the remaining 40 ma. consists of the screen and grid currents which are indicated on the meter, as the meter is in the cathode circuit of the stage. If it is not possible to tune to a dip or obtain 150 ma. or more loaded plate current when using an antenna of more than 40 feet, it may be necessary to short out two or more turns of L_1 until proper loading is obtained.

One small point should be mentioned regarding the antenna with which this transmitter may be operated. Although it will be found possible to load up this transmitter satisfactorily with any length wire from five feet upward, the longer the antenna the better the results. A 50 or 60 ft. antenna gives excellent results.

Although this little transmitter will no doubt be merely a stepping stone for the average Novice as he acquires more technical knowledge and operating skill, if it is carefully constructed it will be available as the extra or emergency rig in the shack.

-30-

January, 1954

Check! these N.J.R.T. TUBE prices 70% to 90% off list . . .

Type	Price	Type	Price	Type	Price
1A7CT	.45	6AG5	.37	6SN7GT	.39
1B3GT	.42	6AG6	.35	6SL7GT	.46
1H5GT	.38	6AT6	.35	6SN7GT	.50
1L4	.44	6AU4GT	.69	6SQ7GT	.35
1L6	.41	6AU6	.36	6T8	.54
1LC5	.49	6AV6	.35	6U8	.59
1LN5	.49	6AX4GT	.57	6V6GT	.37
1N5GT	.40	6B6	.42	6W4GT	.42
1R5	.43	6BA7	.57	6W6GT	.45
1S5	.37	6BC5	.42	6X4	.35
1T4	.43	6BD6	.45	6X5GT	.35
1U4	.43	6BE6	.37	7F8	.63
1U5	.37	6BG6G	.92	12AL5	.40
1A2	.52	6BH6	.44	12AT6	.35
3A2	.43	6BJ6	.41	12AT7	.54
3Q4	.46	6BK7	.65	12AUG	.38
3Q5GT	.47	6BL7GT	.60	12AU7	.41
354	.44	6BQ6GT	.57	12AV6	.50
3V4	.45	6BQ7	.80	12AV7	.57
5AZ4	.50	6BZ7	.89	12AX4GT	.46
5U4G	.45	6C4	.39	12AX7	.49
5V3GT	.30	6CB6	.42	12BA6	.36
5V4G	.33	6CD6G	1.09	12BA7	.44
5Z3	.37	6FG6	.37	12BE6	.37
6A3	.57	6FGT	.35	12BM7	.65
6A6	.49	6J5GT	.40	12SA7GT	.42
6AB4	.42	6J6	.50	12SK7GT	.46
6AF4	1.06	6KG6T	.35	12SN7GT	.50
6AF6	.75	6L6	.62	12SQ7GT	.42
6AG5	.41	6L5	.37	12SR7MET	.47
6AJ5	.88	6S8GT	.51	12V6GT	.60
6AK5	.73	6SA7GT	.41	19BG6G	.96
6AL5	.36	6SD7GT	.39	19T8	.77

Guarantee

ALL NJRT TUBES ARE BRAND NEW AND FULLY GUARANTEED FOR 1 YEAR

Type	Price
25BQ6GT	.60
25L6GT	.37
25W4GT	.45
25Z6GT	.35
35A5	.50
35B5	.38
35C5	.37
35L6GT	.40
35W4	.35
35Z3	.43
35Z5GT	.35
42	.40
43	.53
45	.53
50B5	.37
50C5	.37
50L6GT	.39
70L7GT	1.07
76	.42
117Z3	.35
807	.97

T.V. PIX TUBE BRIGHTNER \$1.59
LOTS OF 10 \$1.49

Free 50

assorted condensers with every tube order of \$25.00 or more.

For T.V. sets where voltage supply is low AC LINE BOOSTER with safety fuse and switch \$5.95



Many 7 volt types not listed. All tubes individually boxed. Minimum order \$10.00. Tubes offered subject to prior sale. Prices subject to change. Orders shipped prepaid if check is enclosed. 25% deposit required on c.o.d. shipments.

SEND FOR FREE TUBE LISTING

NEW JERSEY TELEVISION SUPPLY CO.

906B WESTFIELD AVE., ELIZABETH, N. J. EL 3-6166

Only STEVE-EL can make an offer like this!

Famous make 21" TV CONSOLE



Complete ready to play \$169.95

STEVE-EL brings you the TV buy of the year. This is not a kit but a factory wired and aligned chassis. The price is far below wholesale so the famous manufacturer does not want his name mentioned. The chassis can be bought with tubes or without or complete in beautiful mahogany cabinet all 3/4" wood. Complete sets come in 17" or 21". Here is truly exceptional quality TV which will outperform most receivers on the market today. Employs the finest of modern engineering innovations assuring the clearest, sharpest picture ever.

Just a few of the many features:

- * K.F. Amplifier on all inputs. * Stage I. F. system. * Peak A.C. C. * Kinoscope cathode fed with DC restoration. * Balanced AFC system. * High Voltage using 2-1N2A. * Frequency Modulation Sound. * Range 44-88Mc (71-116 Mc. * 12 Channels of VHF. * Separate power supply with voltage regulator. * Plug in yoke assembly. * Vertical integrator system. * AC interlock. * Filtered heater wiring for I.F. amplifier. * Wide range of adjustment controls. * 100 Ohm yoke. * Precision matched components assuring efficient maximum performance. * Heavy duty Alnico V 19" PM Speaker. * Complete circuit diagram. * Tubes: 1-2U1, 1-6BQ6, 2-1N2A, 1-6V6, 1-6AX4, 1-6SQ7, 1-6R6, 1-6AL5, 1-6AG7, 1-6AU6, 3-12BH7, 1-6J6, 1-6BR6

Chassis 14 1/2" wide, 19" deep (controls included). Power supply 141/4" wide, 9" deep.	\$49.95
Complete Chassis Less Tubes	\$4.95
Complete Chassis with Tubes (less Picture Tube)	\$4.95
Complete Chassis with Tubes and 17" Picture Tube	\$6.95
Complete Chassis with Tubes and 21" Picture Tube	\$9.95
Complete Chassis with Tubes and 17" Picture Tube in cabinet as illustrated, with Safety Mask and Back.	\$159.90
Complete Chassis with Tubes and 21" Picture Tube in cabinet as illustrated, with Safety Mask and Back.	\$169.90

We have only a limited quantity of cabinets. First Come, First Served. Cabinet 10" High x 33" Wide x 22" Deep.

At Our 2 Stores: 61 Reade St., New York 7, N. Y. 166 Washington St., New York, N. Y.

Order by Phone: COrtlandt 7-0086
Order by Mail: Dept. RN-1, 61 Reade St., New York 7, N. Y.

STEVE-EL ELECTRONICS CORP.
Dept. RN-1 61 Reade St., New York 7, N. Y. COrtlandt 7-0086

BC-640 TRANSMITTERS



FREQUENCY
100-158 Mcs.

POWER
110-125 V or
220-250 V
60 cy. Sing. Ph.

OUTPUT
75 Watt push-
pull HK 24G

MODULATION
Class B - AM

An efficient crystal controlled ground station complete with power amplifier, oscillator driver, modulator, control panel, dual power supplies, and power control.

Although originally designed for communications from ground to plane, it is currently used by police, taxi, ambulance and other special installations operating within these frequencies.

BC-639 RECEIVERS

Designed to work in conjunction with the BC-640 Transmitter at 100-158 Mcs. Supplied with RA-42, 115V 60 cy power supply. One RF and three IF stages AM or CW.

Technical Manuals

We recently purchased, from the government, a large quantity of technical and operating manuals on **RADIO, RADAR and AIRCRAFT** equipment. Send for our listings.

AN/ARN-6 ADF

We believe this is the ...
FIRST U. S. GOVT. RELEASE
... of a quantity of ARN-6 Radio Compass Equipment. All sets are complete with receiver, indicators, control boxes, racks, plugs, cables, and loop antenna. Spare AS 313 antennae and other components are available.

SCR-274N Comm'nd

Complete Installation or Components

BC-453-A Rad. Rec.	DM-32-A Dyn.
BC-454-A Rad. Rec.	DM-33-A Dyn.
BC-457-A Rad. Trans.	BC-456-A Mod.
BC-596-A Rad. Trans.	FT-277-A Rack
BC-496-A Rad. Con. Box	FT-226-A Rack

Plugs, couplings, adapters and tuning shafts

RADAR EQUIPMENT

Complete Installation or Components
SCR-291, APS-3, APS-4, APS-6, APS-15,
APO-13, Mark 16, Mark 28.

Certified - Guaranteed

All equipment is sold with our certified, unconditional guarantee, checked and tested in our own shop. We are a recognized and approved supplier for Foreign and U. S. Govt. Agencies. We invite your inquiries for supply or technical data.

A DIVISION OF
Arnold A. Semler, Inc.
6855 TUNJUNGA AVENUE
NORTH HOLLYWOOD, CALIF.

NEW EQUIPMENT FOR THE AUDIO TECHNICIAN

MATCHED CABINETS

G & H Wood Products Co., 75 North 11th St., Brooklyn 11, N. Y. has introduced a pair of matched cabinets which have been designed to house all of the equipment necessary for a complete high-fidelity system.

The equipment housing handles a record changer, tuner, and amplifier



in its frame which measures 35" high, 23½" wide, and 17½" deep. The companion speaker cabinet has the same over-all dimensions. Its baffle volume is 6½ cubic feet; 22" wide, 31" high, and 16" deep. An individual speaker cutout is made available.

The Models 21 and 22 are available in hand rubbed wood in the following finishes: French mahogany, limed oak, honey walnut, and black lacquer.

BINAURAL AMPLIFIER

Bell Sound Systems, Inc., Columbus 7, Ohio has announced a binaural amplifier which is complete with a self-contained power supply, preamps, and controls.

The Model 3-D includes three dual sets of inputs. Dual flat inputs for radio and tape and a pair of dual inputs for phonograph records are provided. Two sets of phono inputs provide for use of either high- or low-impedance magnetic pickups and are equalized for all existing binaural records.

The unit is designed so it may be

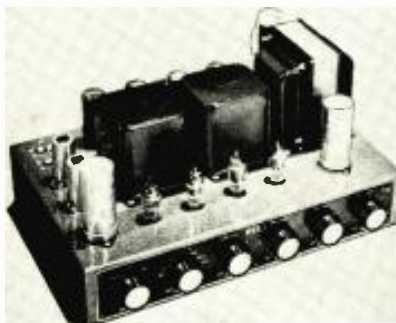

used for monaural reproduction of conventional broadcasts, records, or tapes

through one or both channels. In addition to a three-station input selector, the unit has a six-position function switch to select binaural, monaural, or reverse binaural either with or without loudness control.

Specifications on the amplifier are available from the company.

BINAURAL RECORDER

Electronic Teaching Laboratories, 1818 M Street, N.W., Washington 6, D. C. is now offering the "Electro-Dual" binaural tape recorder equipped with Brush "Red Heads."

The unit provides two parallel tracks which may be used separately or together with the assurance that they will be in exact time relationship with one another.

Although specifically designed for classroom use, the new recorder may be used for commercial applications. All components, which are mounted on a heavy aluminum plate, can be removed in one piece for simplified maintenance.

AM-FM TUNER

Approved Electronic Instrument Corporation, 928 Broadway, New York 10, N. Y. has added a 12-tube AM-FM



tuner to its line of audio equipment.

The V12 uses a stage of r.f. on both the FM and AM bands. It has a 456 kc. i.f. and crystal detector on AM and a two-stage 10.7 mc. i.f., two limiter stages, and a discriminator combination on FM.

The set uses printed circuit type condensers, temperature compensated where needed. It also features common slide rule tuning with separate r.f. and i.f. channels on AM and FM.

The tuning range is 530-1650 kc. for AM and 88-108 mc. for FM. The tuner measures 8" x 8" x 5½".

PREAMP-EQUALIZER

Fisher Radio Corporation, 39 E. 47th Street, New York 17, N. Y. is now in production on a new preamplifier-equalizer, the Model 50-PR.

The new unit is self-powered and features separate equalization settings for high-frequency roll-off and low

D. C. RELAYS



CR2792B116A3

SPST—50 Amp. Contacts. Operates from 22-30 VDC. Coil Res. 200 Ohms. Completely enclosed in transparent plastic case, which may be removed for adjustments.....\$1.59

GE #CR2791B116W3

Same as above, except additional terminal brought out from contact arm.....\$1.74

GE #CR2791F100D3

Differential: DPST. Norm. open. Dual coil, 1500 ohms per coil—25 Ma. Operating Current. Contacts: 20 Amp.\$2.25

GE #CR2791F100G3

Same as above, except has extra 1A contact. Rated 5 Amp.\$2.35

GE #CR2791D101F3

All Ceramic Insulation. DPDT. Coil—12VDC. 100 Ohms DCR. Contacts designed for fast operation. Rated at 5 Amps.\$1.25

GE #CR2791B104J3

3PDT. 5 Amp. contacts. Coil rated 22-30VDC. 150 Ohms DCR. Contacts are designed for fast operation, and enclosed by clear plastic cover.....\$1.35

GE #CR2791B104C3

SPDT. Dual Contacts will handle 20 Amps. Coil: 18-28VDC. 125 Ohms DCR.....\$1.25

MOBILES! C. D. MEN! CAP!!

IDEAL DYNAMOTOR — CONVERTS EASILY TO SUPPLY UNIT DELIVERING

12 Volt Input 6 Volt Input
610 V @ 150 MA OR 300 V @ 90 MA
325 V @ 125 MA OR 160 V @ 110 MA
Brand New with Conversion Data.....\$3.75

DYNAMOTORS

TYPE	INPUT VOLTS	AMPS	OUTPUT VOLTS	AMPS	PRICE
DM 416	14	6.2	540	.250	\$4.75
OM 33A	28	7	540	.250	3.95
BD AR 93	28	3.25	375	.150	7.50
23350	27	1.75	285	.075	3.95
D-19 Pack	12	9.4	275	.110	6.95
DA-3A*	28	10	500	.950	6.95
			150	.010	
5053	28	14	250	.060	3.95
PE 73 CM	28	19	1000	.350	22.50
BD 69†	14	2.8	220	.08	12.95
D-402†	13.5	12.2	300	.200	12.50
SP 175	18	3.2	450	.06	4.49
DM 25†	12	2.3	250	.05	6.95

* Replacement for PE 94.
† Used, Excellent

INVERTERS

PE-218-H: Input: 25/28 vdc. 92 amp. Output: 115v. 350/500 cy 1500 volt-amperes. NEW.....\$37.50
PE-206: Input: 28 vdc. 36 amps. Output: 80 v 800 cy. 500 volt-amps. Dim: 13"x5½"x10½".
New.....\$22.50
NAVY COR-211095: Input 22-30 VDC/75-60A.
OUTPUT: 115V/400 CY. 1 KVA/8.7A. RPM: 4800.
With coupling provision for motor. Brand New.
Original packing.....\$150.00

SELENIUM RECTIFIERS*

Current (Continuous)	18/14 Volts	36/28 Volts	54/42 Volts	130/100 Volts
1 Amp.	\$1.35	\$2.15	\$3.70	\$8.50
2 Amps.	2.20	3.60	5.40	10.50
2½ Amps.	4.20	7.00	8.00	13.00
4 Amps.	7.00	12.00	12.95	23.25
6 Amps.	4.75	9.00	13.50	33.00
10 Amps.	6.75	12.75	20.00	44.95
12 Amps.	8.50	16.50	25.00	59.00
20 Amps.	13.25	25.50	38.00	79.50
24 Amps.	16.25	32.50	45.00	90.00
30 Amps.	25.00	48.50		
36 Amps.				

* F. W. Bridge

INTERPHONE AMPLIFIER



Easily converted to an ideal Inter-Communications set for office, home or factory. Original. New w/conversion diagram.....\$4.75

INTERPHONE TRANSFORMER SET

Rig your own interphone. Kit consists of 1-Input Transformer (Matches 4 or 6 OHM SPKR to Grid) and 1-Output Transformer (Matches 50L6, 35L6, 25L6, etc., to 4 or 6 OHM Speaker Set) \$1.00 of 2 XMRS. ONLY.....\$1.00

RECTIFIER TRANSFORMERS

Pri: 115V, 60 Cy. Sec: 28V/3.1A, 26V/8.4A
7.3V/14A.....\$12.95
Pri: 210/215/220/225/230/235/240V, 60 Cy., 1 Phase
Sec: 11/10/7.5/5VCT @ 35A.....\$19.50
Pri: 115V 60 Cy. Sec: 8.1V @ 1.5A.....\$1.39
Pri: 115V 60 Cy. Sec: 18.5V @ 5A.....\$4.25

12-14V SUPPLY KIT

Delivers 12-14VDC at 3.5A from 115V, 60 cy. Kit contains 1—Transformer Rated 18.5V, 4A, 1—Selenium Rectifier, F. W. Bridge.....\$6.95

Send M.O. or Check. Shipping Chgs. C.O.D.
COMMUNICATIONS EQUIPMENT CO.
181 Liberty St. Dept. N-1 New York City 7, N. Y.

frequency turnover. There are sixteen possible combinations of equalization settings.

The Model 50-PR can be used with low-level magnetic pickups of any make. It is housed in a plastic cabinet

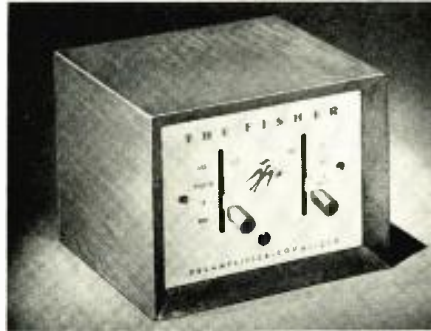

with an etched brass control panel. A special circuit design permits the use of an output cable of any length up to fifty feet. The unit measures 47/16" high, 5 3/8" wide, and 5" deep.

The company has a data sheet on this unit which will be forwarded upon request.

RCA INTERCOM

The Engineering Products Department of Radio Corporation of America, Camden, N. J. has introduced a new low-cost telephone-type intercom system which has been tradenamed "Duo-Com."

The new system is designed for use in homes, professional offices, farms, schools, business, and industry. This simplified system provides instant voice communication and will operate more than a year on a single six-volt battery. Contact between phones is made simply by lifting the receiver and depressing a button, eliminating dialing, switchboard, press-to-talk keys, and similar delays found in other intercoms.

The company's electronic parts distributors and sound system distributors are handling the "Duo-Com."

LOW-PRICED RECORDER

Telectrosonic Corporation, 35-18 37th Street, Long Island City, N. Y. has recently introduced a low-priced tape recorder, the "Telectrotape."

The unit features dual-track recording, fast forward and rewind, a tape



speed of 3 3/4" per second, high-impedance input for microphone, radio, record player, etc. and one hour recording time from a 5" reel of tape.

The recorder includes a recording

Do as TV manufacturers do... use Hi-Vo-Kaps®



Centralab TV Hi-Vo-Kaps are the accepted standard of television manufacturers. That's why they're the recognized service leader too!

They will withstand continuous overload, up to TWICE rated working voltage — and come back for more! Capacitors are complete, ready to install.



Hi-Vo-Kaps are 100% tested at rated test voltage. You get a factory-guaranteed exact replacement every time.

Use Hi-Vo-Kaps for filter and by-pass in TV high-voltage power supply... and pulse filter for cathode ray tubes. You'll find them the fastest... safest for guaranteed servicing capacitors you've ever used. Ten different combinations available — individually packaged for instant use. See your Centralab distributor for stocks NOW.



Centralab

CENTRALAB,
A Division of Globe-Union Inc.
910-A E. Keefe Ave., Milwaukee 1, Wis.

Please send me latest technical data on Centralab's Ceramic TV Hi-Vo-Kaps.

Name.....

Firm.....

Address.....

City.....Zone.....State.....



Prescribed by top mfrs.*

For operating and testing DC equipment from AC lines

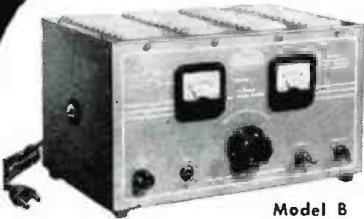

Model B



FILTERED DC POWER SUPPLY

Pat. 2399748

They say: "It's the only one that can withstand continuous high overloads!"

Cooler Operation—Selenium rectifier application and conduction cooling dissipate over 3 times the heat.

Twice the Rectifier Power Rating with EPL Patented Design. Lowest Cost Per Ampere Output.

Output 6v., 1-20 amps. (35 at peak). 2 units in parallel supply 6v. at 40 amps.

Tests 2 Auto Radios with push-button solenoids at same time; also motors, instruments, relays, other low voltage devices.

NEW MODEL C-12 services both 12v. and 6v. auto radios.

* Names on request

ELECTRO PRODUCTS LABORATORIES

4501-Nb Ravenswood Avenue, Chicago 40, Ill.

Canada: Atlas Radio Corp., Ltd., Toronto, Ont.

FREE! New Detailed Literature on America's Only Complete Line!

South River
★★ NEWS ★★
CHIMNEY CORNER GUARD



Box of Six 49¢

An exclusive South River device for protecting, strengthening, and safeguarding chimney and strapping. Prevents chipping of chimney. Permits uniform tightening of banding. Safeguards mounting equipment. South River Antenna Mounting Accessories are carried by every leading TV Parts Jabber from coast to coast.

Write for your copy of our new 1953 catalog

In Canada A. T. R. Armstrong Co., Toronto

SOUTH RIVER METAL PRODUCTS CO., INC.
SOUTH RIVER, N. J.

PIONEER AND OUTSTANDING PRODUCER OF FINEST LINE OF ANTENNA MOUNTS



THE Case WITH A 1,000 APPLICATIONS

This all-purpose case is ideal for housing meters, controls and switches of all types.

Made of heavy molded black plastic with matching phenolic panel.

Easy to drill and saw.

Available in two sizes:
5-1/4" x 6-7/8" x 2-5/16"
3-3/4" x 6-1/4" x 2"

Ask your Distributor for Waldom's Plastic Case.

WALDOM ELECTRONICS INC.
911 Larrabee St., Chicago 10, Ill.

level indicator and a single control for record, play, and idle. It operates from 117 volts, 60-cycles. It comes complete with microphone, 5" reel of pre-recorded tape, an extra reel, and power cord.

It measures 7" x 10" x 11 1/2" and weighs just 14 pounds.

MITCHELL PHONOGRAPH

Mitchell Manufacturing Company, 2525 Clybourn Ave., Chicago, Ill. has added a "3-D" record player to its line of audio equipment.

According to the company, the new unit transmits a full range of musical tones without custom building. The player will cover the frequency spectrum to 20,000 cps. It comes completely enclosed in a 3/4" wood cabinet measuring approximately 17" wide, 25" deep, and 13" high. Its wrought-iron legs may be removed to transform it into a table model.

The player will handle 7", 10", and

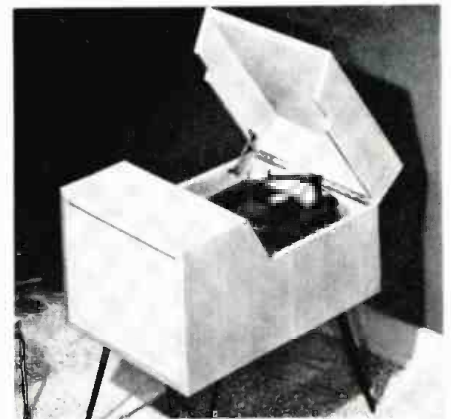

12" records at 33 1/3, 45, and 78 rpm. Its record changer permits continuous play for four hours.

CRAFTSMEN FM TUNER

The Radio Craftsmen, Inc., 4401 N. Ravenswood, Chicago 40, Ill. has recently introduced a new FM tuner, the Model C900.

The tuner is designed for extreme sensitivity, minimum distortion, and maximum stability. The circuit incorporates a cascode double-triode r.f. amplifier which gives sensitivity of 1 µv. for 20 db quieting, photoetched high-capacity i.f. coils, a 20.6 mc. i.f. channel, low regeneration and easily-aligned transitionally-coupled i.f. stages resulting in less than .05 per-cent intermodulation distortion, amplified a.f.c., and continuously variable a.f.c. for easy tuning of weak stations.

The company will supply full details on request.

BROCINER UNIT

Brociner Electronics Laboratory, 344 E. 32nd Street, New York 16, N. Y. has announced the availability of a new preamp-equalizer, the Model A100PV.

The new unit features adjustable record compensation, separate controls for turnover and roll-off, and universal pickup compensation. This latter

feature provides a simple and convenient means of matching the pre-amp input to all leading makes and

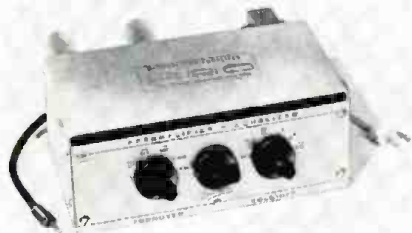

types of pickups. This is accomplished without the addition of any resistors, condensers, or the use of any tools.

The Model A100PV is self-powered and is equipped with a panel-mounted volume control, "on-off" switch and pilot light in addition to the turn-over and roll-off switches.

BINAURAL TAPES

Concertapes, 224 S. Michigan Ave., Chicago 4, Ill. has announced the issue of the first of a series of pre-recorded monaural and binaural tapes by the Fine Arts Quartet.

Issued under the new "Concertapes" label of the Chamber Music Society of Chicago, the first offerings will consist of Debussy's "Quartet in G Minor" and Dvorak's "Quartet in F Major."

Additional releases will be made periodically and will include works drawn from the classical, romantic, and contemporary masterpieces of the chamber music literature.

The Fine Arts Quartet is comprised of Leonard Sorkin, first violin; Joseph Stepanky, second violin; Irving Ilmer, viola, and George Sopkin, cello.

NEW TURNTABLE

Weathers Industries, Barrington, N. J. is now offering a smooth, satin-finish turntable that is easy to clean and never touches the record's playing surface.

Tradenamed the "Debonnaire," the new turntable permits the record to ride high on a cushioned float which is



just the size of the record label. The new unit is designed to be used with the company's FM pickup which is light enough to operate properly on the new turntable.

Write the company direct for full details on either of these units.

PHONO CARTRIDGE

Astatic Corporation of Conneaut, Ohio is now marketing a new turnover needle cartridge, the Model GCD.

The new unit features a revolution-

GONSET'S NEW DE LUXE

TV Remote Control

FOR USE WITH ANY TELEVISION RECEIVER



The Gonset De Luxe Remote is a complete TV front-end: Cascade RF, Mixer-oscillator, (Standard Coil Tuner), I.F. booster stage and integral power supply.

No loss in picture quality or brightness. Actually improves many of the older sets.

May also be used as UHF converter as turret tuner has provision for snap-in coil strips.

Has earphone provisions! Ideal for sick-rooms, hospitals, "Night owl" listening

Connects to I.F. of existing receiver. Two models cover standard TV I.F. frequencies. Doesn't require major set alterations

SERVICE DEALERS

You'll want full technical and dealer price information on this highly popular item. Write today. (Business letterhead, please.)

Now . . . you can sit back and relax in that comfortable chair and really enjoy your TV viewing. There will be no need to jump up to change to another program . . . or to make adjustments in contrast . . . or in audio volume level. Now . . . all this can be done right from where you sit with the new Gonset De Luxe Remote Control!

This compact unit, housed in a smartly styled Blonde or Mahogany cabinet sits on a small end table or on the floor beside your chair . . . takes over all TV panel controls . . . places them directly at your fingertips. An unobtrusive cable, colored to blend into the background of walls or carpeting, makes complete connections to your TV set. Here is a really simple, troublefree arrangement that may be used with any make or model TV set, old or new.

There's no loss of picture or sound quality . . . can actually effect a decided improvement in many older model sets. No danger of obsolescence either . . . your Gonset unit can be shifted to any new set you may subsequently purchase.

There's also provision for earphones. Now . . . personalized TV listening and viewing at any hour without objection by family or neighbors.

Write today!



801 South Main St., Burbank, Calif.

REALLY ENJOY YOUR TV
Sit back and relax with a Gonset De Luxe TV Remote at your elbow.

GONSET CO. DEPT. RT-2
801 South Main St., Burbank, Calif.
Please send further details and price information on your new De Luxe TV Remote Control Unit.

NAME _____

ADDRESS _____

DEALER _____

GET YOUR COMMERCIAL TICKET EASIER WITH . . .

RADIO OPERATOR'S LICENSE Q AND A MANUAL
(4th Edition)
by Milton Kaufman
Covers Elements 1 through 8. Complete discussion of answers to every technical question in the F.C.C. Study Guide! Used by over 50 leading schools. Only \$6.60 at jobbers, bookstores or direct from—



JOHN F. RUDER Publisher, Inc.
480 Canal Street, New York 13, N. Y.

WANTED

WE NEED YOUR SURPLUS ELECTRONIC EQUIPMENT

WE PAY TOP \$\$\$ FOR:

- ★ RADIO RECEIVERS
- ★ TRANSmitters
- ★ ARC-1
- ★ ARC-3
- ★ ART-13
- ★ CONTROL BOXES
- ★ INDICATORS
- ★ CLAMPS
- ★ PLUGS
- ★ CORES
- ★ RELAYS
- ★ TELEPHONE MATERIALS
- ★ AN CONNECTORS
- ★ WE BUY ANYTHING!

Write, write today! Tell us what you have.
TALLEN CO., Inc., Dept. RN
159 Carlton Ave., Brooklyn 5, N. Y.

BASIC NEW HIGH FIDELITY DISCOVERY

**Revolutionary
acoustics principle
for enclosures!**

The Karlson Ultra-Fidelity Enclosure is **NEW!** It embodies an original sound principle—the first such basic invention in years. The Karlson, using the Exponential Coupler, creates a profound sound improvement over all other makes, regardless of price or size.

MODEL 15M



Blond and Mahogany
\$117.60

The Karlson Ultra-Fidelity Enclosure is only 34½ inches high, but outperforms horns thirty feet long. Its dimensions are less than 6 cubic feet yet it outdoes a 2700 cubic foot infinite baffle! See and hear the Karlson—unmatched in performance, craftsmanship and beauty.

SPECIAL KIT!

MODEL 15PK

The Karlson Ultra-Fidelity Rough Plywood Kit. 34 precision cut pieces, exactly routed sides, no special tools required for quick assembly.

NOTE: Buy kit intact—making parts at home extremely difficult.



¾" Plywood Kit
\$45.

SPECIFICATIONS OF ENCLOSURES

Size: 34½ x 22½ x 18. Specially designed internal chamber with front and back speaker loading. Fundamental coupling below 25 cycles. Designed for co-axial speakers.

If not yet available at your Hi-Fi dealer, order direct. For further information, write to:

KARLSON ASSOCIATES

INCORPORATED
Receiving Dept.

1379 EAST 15 ST. • B'KLYN 30, N. Y.

ary design in which the cartridge remains stationary in the pickup arm. Only its double-tipped needle rotates in switching back and forth to play both narrow- and wide-groove records.

According to the company, increased output and new stability of response are the major improvements attributable to the new design.

Output is listed as one volt and the frequency range is from 50 to 10,000 cps. Minimum needle pressure requirement is six grams.

Unusually high sensitivity and compliance, low needle talk, ease of installation, and the elimination of preamps or equalizers are other features of this unit.

TAPE RECORDER

Lion Manufacturing Corp., 2640 W. Belmont Ave., Chicago, Ill. has recently introduced a compact tape recorder which incorporates several novel features.

The recorder will operate without being opened up—a small control panel

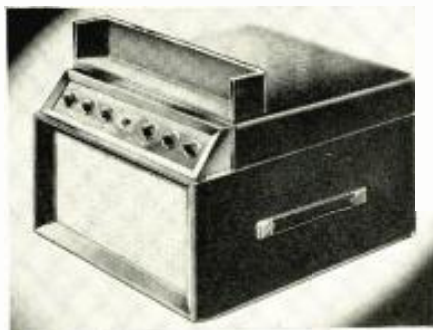

is lifted in order to put the recorder in operation. It will play for 16 consecutive hours.

Current plans call for the manufacture of three models—for home, commercial, and military use.

ONE-INCH MICROPHONE

Shure Brothers, Inc., 225 W. Huron St., Chicago 10, Ill. has announced the availability of the MC series of magnetic microphones which are only 1-inch in diameter.

These controlled reluctance units were designed to be immune to varying conditions of heat and humidity. They may be used with transistor circuits but are equally applicable to other devices.

Detailed technical information is available from the manufacturer.

WALL HORN

Brociner Electronics Laboratory, 344 E. 32nd St., New York 16, N. Y. is now offering its Model 4W wall horn which features, in effect, a "built-in" corner.

The 4W is powered by a twin-cone driver unit designed especially for horn loading over the entire audible range. The middle range and treble frequencies are dispersed uniformly by a reflector horn of unique design. For the bass range, the back of the horn is coupled to the air by means of two folded horns.

My Start in TV Servicing

(Continued from page 67)

My neighbor was so happy with the first one that he picked up another for a friend of his, paying \$5.00 extra to get one in working order. But it would only work for about 15 minutes—10 minutes longer than he had tried it out in the store.

Obviously this was another case for the now beloved v.t.v.m. First effort was to signal trace each stage, starting with the r.f. probe on the second video i.f. (signal not strong enough on the first i.f.), leaving the probe hooked on, and watching for a change. It was soon apparent that this procedure would take all winter. So careful readings were made of the signal at each grid from second i.f. to picture tube, and the readings jotted down. (The peak-to-peak scale was used, of course, for the stages past the video detector, in this case a crystal.)

Fifteen minutes later the trouble was cornered. The signal dropped drastically at the grid of the video amplifier. Sound changed but little, but the picture was wiped out. Yes, the trouble was the crystal detector, a cantankerous device which has the quality of changing characteristics sufficiently to foul up the picture without upsetting the sound.

Case 12—No horizontal or vertical sync, sound OK: Picture could be locked momentarily with the vertical hold control. So, the contrast was turned down, and brilliance turned up, to see if picture showed the vertical sync signal OK. It did, which meant that things were probably cooking that far along in the set, and the trouble was probably a sync separator tube. That it was!

Case 13—Set would work OK for a couple of hours, then would lose horizontal sync: The set was the first which the writer tackled which used the pulse-width frequency control circuit (see Fig. 2). The first guess was that the synchronization could be restored by carefully following the alignment sequence in the service notes for the receiver.

After half an hour of adjusting the screw on the horizontal frequency coil and the horizontal lock range trimmer, it was apparent that something more than a living-room-floor repair job had turned up. Since the writer's service scope, to be built up from a kit, was still just a miscellaneous collection of parts, the first effort was to make voltage and resistance checks of the various components. Everything was perfect. So the horizontal transformer was replaced. But that didn't help a bit.

Obviously, something more than a v.t.v.m. was needed, so a scope was borrowed from a long suffering friend. Sure enough, the double hump waveform supposed to be on the horizontal lock range coil was way out of whack. Adjusting the horizontal lock range

Terrific Transmitter-Receiver Buy!
FAMOUS BC-645 450 Mc.—15 Tubes



BRAND NEW, in original carton! Easy to convert for phone or CW 2-way communication, covering these bands: 420-450 Mc Ham Band, 450-460 Mc fixed or mobile, 460-470 Citizens Band, 470-500 Mc TV experimental. Contains 15 tubes: 4-7F7, 4-7H7, 2-7E6, 2-6F6, 2-955, 1-WE-316A. Size 10 1/2 x 13 1/2 x 4 3/4". Wt. 25 lbs.

BRAND NEW
\$3950
 each

CONVERSION DIAGRAM INCLUDED!

PE-101C DYNAMOTOR for above BC-645. **\$4.85**
 UHF ANTENNA ASSY. for above BC-645. **\$2.45**

Sensational Buy!
MODULATED BC-221-AK FREQUENCY METER



BRAND NEW! Limited quantity, first come, first served! Range 125 to 30,000 Mc, with crystal check points in all ranges. Complete with tubes, crystal, calibration charts. Your cost, BRAND NEW. **\$210.00**

NEW Used, Excel. Cond. with tubes & crystal. **\$129.50**
SCR-522 BARGAIN OFFER!
 SCR-522 Xmitter less tubes \$22.50 with tubes. **\$32.50**
 SCR-522 Recvr less tubes \$19.50 with tubes. **\$24.50**

DYNAMOTORS

Type	Input	Output	Excellent Used	BRAND NEW
DM-32A	28V 1.1A.	250V .05A.	\$4.90	\$7.50
DM-33A	28V 5 A.	575V .16A.	2.25	3.95
	28V 7 A.	540V .25A.		
DM-34D	12V 7.8A.	220V .080A.	14.50	
DM-37	25.5V 9.2A.	625V .225A.	14.75	
DM-40	14V 3.4A.	172V .138A.	7.40	9.50
DM-28	28V	224V .07A.	3.95	6.95
DM-21	14V	235V .09A.	6.85	16.50
PE-73	28V 20 A.	1000V .350A.	9.50	12.50
PE-86	28V 1.25A.	250V .060A.	2.95	5.50
PE-94A	28V 10 A.	300V .200A.	7.50	11.50
		150V .101A.		
PE-94B	28V 10 A.	300V .200A.	8.50	11.75
		150V .101A.		
PE-94C	28V 10 A.	300V .200A.	19.00	12.75
		150V .101A.		
PE-98	14V 21 A.	300V .200A.	22.50	37.50
		150V .101A.		
PE-101	13V 12.6A.	400V .135A.	3.75	4.85
	26V 6.3A.	9V AC. 1.12A.		
PE-103	6V 12V	500V .160A.	27.50	44.50
		500V .160A.		
PE-104 (Vibrator)	6V 1A.	84V .09A.	12.50	14.50
	12V 5 A.	51V .03A.		
DM-414 (with filter)	14V 2.8A.	220V .080A.		12.50
PS-225 (with filter)	28V 3.2A.	375V .150A.		10.50
ETCOR Dynamotor	27V 6.05A.	300V .200A.		9.95
		18V AC 2.2A.		
PE-135AX (with filter)	24V 12 A.	500V .200A.		34.50
GENERATOR				
GN-39-F	14.6V 25 A.	1000V .350A.		39.50
	(16" L. 8" dia. 50 lbs.)			
INVERTERS				
PE-206 Inverter—Leland	In: 28V DC—38A.			
	Out: 500V 800 cyc. 80VA. 1 Ph.		9.75	12.50
PE-218 Inverter—Leland-Wincharger—GE.	In: 28V DC—92A.			
	Out: 115V 380/500 Cyc. 1500VA. 1 Ph.		16.50	24.50

HEADSETS

	Excellent Used	BRAND NEW
HS-23 high impedance	2.95	4.75
HS-33 low impedance	2.45	5.75
HS-30 low imp (weatherwt)	1.49	2.45
HS-15 U. high imp (2 units)		4.95
CO-307A cords, with PL55 plug and JK26 jack, 8' long		1.19



CARBON HANDMIKE

Sig Corps, 200 ohm single button. Press to talk switch, 4' cable, plug. BRAND NEW. **\$5.95**

T-45 Lip Mike, navy type. **USED \$1.45 NEW \$4.75**
T-30 Throat Mike **USED \$1.49 NEW \$4.85**
Willard 6-Volt Midget Storage Battery
 3-amp hr. BRAND NEW. 3 1/2" x 1 1/2" x 1 1/2" x 2 3/8". Uses standard electrolyte. **\$2.65**
Willard 2-Volt Storage Battery
 20 AMP. HR. BRAND NEW. **\$2.69**
1-QUART ELECTROLYTE FOR ABOVE
 ENOUGH FOR TWO CELLS. **\$1.45**
7-PRONG 2-VOLT VIBRATOR. FOR PORTABLE AND FARM SETS (GE L8530). **\$1.49**

Please include 25¢ deposit with order—Balance C.O.D. MINIMUM ORDER \$3.00. ALL Shipments F.O.B. Our Warehouse N. Y. C.

FREE CATALOG Supplement

Marvelous values in Brand New Surplus Equipment. Send TODAY for your FREE COPY. Dept. N-1.

G & G Radio Supply Co.

51 Vesey St., New York 7, N. Y., CO 7-4605
 Branch: 16 W. Kinzie St., Chicago, Ill.

slug until the waveform was right, restored horizontal sync, and when last seen about six months later, the set was still performing beautifully.

Moral: You can do a lot of TV servicing without a scope, but when you need one, you need it. (A service manager friend claims that he has bailed out a lot of such sets simply by adjusting the horizontal lock slug until the horizontal control will hold over most of the range. But the method is tricky at best, to be resorted to only when there is no chance to use a scope.)

Case 14—OK on channel 9, but on channel 2, the set might or might not work: Seemed like the trouble had to be in the tuner. So the chassis was pulled out, and the channel 2 coil in the turret tuner taken out and inspected. It looked OK, but for luck, the contact points were wiped clean. When the coils were put back the set was OK.

For the next couple of hours the channels were switched every now and then and eventually the trouble came back. This time I really looked things over and finally noticed that grease, in a clear film, was moving from the bearings on the end of the tuner down onto the contact points. Everything was wiped up; the excess grease around the bearing was sopped up with a piece of cleansing tissue. That did it, and I had learned another one: servicing consists of other things than electronics. You must have a good eye for physical symptoms of trouble.

Case 15—Dark picture tube, sound OK: This one turned out to be a little gem, and is a beautiful example of the service technician creating his own grief.

The usual tube substitutions didn't do a thing, so the chassis was pulled, and the horizontal oscillator tube voltages checked. The peak-to-peak scale on the v.t.v.m. showed drive to the grid of the horizontal output tube. A voltage measurement across the grid resistor indicated that the tube was being driven OK. Bias on the cathode resistor was low, screen voltage was high. A check on the low end of the output transformer showed that boost voltage was normal.

These symptoms should have started me down the straight and narrow. But for some reason they didn't, and I laboriously checked out every part in the high voltage and horizontal sweep circuits. Everything was fine. I'd better sleep on this one.

Next day I tackled it again. Meanwhile, I had talked the job over with a friend who insisted that it must be a horizontal output tube. More to give me something to talk to him about than anything else, I stuck in another one. The set took off immediately.

I couldn't understand it, I had tried a tube before, and had checked all of the tubes in my tube kit by actual substitution in working sets. I looked the 6BQ6GT from the set (the one I had put in it) over for luck. The plate cap came off in my hand. Some-

There's GOOD PAY in this uncrowded field!



LEARN Electric Motor Repair

Learn to service practically any motor in common use—from the smallest to the largest



ELECTRIC MOTOR REPAIR

A complete training course in low-cost book form. 560-pages over 500 special illustrations. Price only \$6.00

It pays to train for something different! Every day, more and more electric motors and control systems are being used in industry and home appliances. The average home has at least 11 motors. Industrial plants use motors by the hundreds. The expert who can keep them working properly is a valuable, well paid man in this Electrical Age!

This big 560-page ELECTRIC MOTOR REPAIR book with over 900 how-to-do-it pictures teaches you fast, easy and right! Every detail is clearly covered—from installing, servicing, repairing to complete rewinding. Thousands of copies are already used in schools, shops and for home study by men who want to get ahead in this fast-growing, well-paid modern profession. And it's an ideal guide if you only want to fix motors at home for yourself and friends.

SHOWS YOU HOW . . . EVERY STEP OF THE WAY

You not only read what to do, you actually see HOW to do it. Unique Duo-Spiral Binding divides ELECTRIC MOTOR REPAIR book into two big sections so that you see both the text and related pictures together. An instructor at your side could hardly make learning any easier!

Covers the entire motor field including AC and DC motors and generators PLUS mechanical, electrical and electronic motor control systems. Right down the line it explains things in a way you can easily understand.

Send no money. Practice from Electric Motor Repair for 10 days and see for yourself before you decide whether or not to buy it!



PRACTICE FROM IT FOR 10 DAYS FREE!

Dept. RN-14, Rinehart Books, Inc., Technical Division, 232 Madison Ave., New York 16, N. Y.

Send me the 560-page ELECTRIC MOTOR REPAIR home-training book for 10-day FREE TRIAL. I will then either return book to you postpaid or send you \$6.00 if I decide to keep it.

Name.....

Address.....

City, Zone, State.....

OUTSIDE U. S. A.—Price \$6.50, cash only—same 10 day return privilege with money refunded.

Trav-Electric

DC to AC

CURRENT CONVERTERS
for Land... Sea... Air

JUST PLUG INTO CIGAR LIGHTER ON DASH

Change 6 or 12 Volt D. C.
to 110 Volt A. C. - 60 cycle



Operates Test Equipment,
All Electric Shavers

SIZE: 2"x2"x3 1/2"

Trav-Electric MIDGET

Model 6-11160, 60 Cycle, 10-15 Watts

\$11⁹⁵
List



- OPERATES
- Test Equipment
 - Turntables
 - Lights
 - Short, Long Wave Radios
 - Portable Phonographs
 - Electric Shavers, etc.

SIZE: 2 1/2"x2 1/2"x4 1/2"

Trav-Electric SENIOR

Model 6-1160, 60 Cycle, 35-40 Watts

\$15⁹⁵
List



- OPERATES
- Curling Irons
 - Radios
 - Turntables
 - Small Dictating Machines
 - Test Equipment,
 - Electric Shaver
 - Portable Phonographs

SIZE: 4"x5"x6"

Trav-Electric MASTER

Model 6-51160, 60 Cycle, 40-50 Watts

\$24⁹⁵
List



- OPERATES
- Wire Recorders
 - Amplifiers
 - Soldering Iron
 - Radios
 - Dictating Machines
 - Turntables
 - Small Electric Drill
 - Electric Shaver

SIZE: 4"x5"x6"

Trav-Electric SUPER

Model 6-71160, 60 Cycle, 60-75 Watts

\$37⁹⁵
List

FULLY GUARANTEED
See your Jobber or Dealer

Terado COMPANY
ST. PAUL 14, MINNESOTA

In Canada Write: Atlas Radio Corp., Ltd.
560 King St. West, Toronto 28, Ont.
Export Sales Division: Scheel International, Inc.
4237 N. Lincoln Ave., Chicago 18, Ill. U.S.A.
Cable Address—Harsheel

how it had burned loose inside of the cap, opening up the plate circuit, a fact which the symptoms should have led me to find in jig time.

Case 16—Dark picture tube, sound OK: A new 6SN7GT horizontal oscillator tube put the show on the road. At long last I was beginning to encounter the same trouble twice in a row!

At that point I stopped keeping my service diary. Partly because I am shiftless by nature and partly because I was beginning to feel quite chesty about the whole thing.

Needless to say, I've since had my come-uppance many times. Apparently it takes years before you can call 'em right every time—if you ever can.

In fact, at least once a week I'm not at all positive that the first 16 sets are the hardest! —30—

Transistor Metronome

(Continued from page 51)

curately calibrated. The "Transistor Metronome" is adjusted until it is in step with known settings of the other instrument, and the settings of R₂ so marked.

Finally, for higher repetition rates, the output of the "Transistor Metronome" and that of an audio signal generator may be connected to an oscilloscope and the calibration points obtained by means of Lissajous figures. The figures obtained will be distorted, since a pulse is obtained from the metronome, but the operator should have little or no difficulty in distinguishing 1:1 ratios.

Applications

Although the "obvious" use of the "Transistor Metronome" is in music, there are numerous other applications, depending on the individual needs and requirements of the operator, and upon his ingenuity in adapting the instrument to his use.

One application, for example, is in the photographic darkroom, where the metronome may be used to audibly "tick" off seconds for timing printers, enlargers, and chemical processes. In this application, a "switch" type unit adjusted to deliver either 1-second or 5-second "ticks" would be valuable.

Still another application is in timing mechanical processes or work movements where the eye cannot be transferred to a stop watch or, similarly, in timing chemical or biological processes. Since the unit is battery operated, it is especially valuable in these applications, and can be easily carried to the job—even outdoors.

Battery operation of transistors also offers the advantage of virtually zero "warm-up" time. Simply turn the unit "on," and it starts working.

Another application is in marking time for physical exercises. Here again, the ease of obtaining extremely slow beats (one for every several seconds) gives advantages over other units. —30—



17" Table
\$119⁹⁵

Pl. 10% Fed. Excise Tax

20" Table
\$129⁹⁵

Pl. 10% Fed. Excise Tax

20" Console
\$139⁹⁵

Pl. 10% Fed. Excise Tax

21" Console
\$149⁹⁵

Pl. 10% Fed. Excise Tax

Check these luxury features: Ultra sensitivity, dynamic range control, UHF adaptability, Duo power supply, Acoustical Sound system... all in a beautiful Mahogany finish cabinet.

Better Prices on quantity lots

ALSO AVAILABLE TV CHASSIS

All sets have full 1-yr. factory picture tube warranty, and standard 90-day RTMA parts warranty. Mail and Phone Orders Filled. \$25 deposit, balance C.O.D.. Shipping Charges Additional.

STEPHEN SALES CORP.

45 Crosby St., N.Y. 12, N.Y. Phone: WO 1-8233

Dealer Inquiries Invited

\$

WE PAY CASH

for all types of
MILITARY ELECTRONIC EQUIPMENT

Top Dollar for:

- BC-348 RCVRs (Bonus on Q & R Models)
- ART-13 & any accessories
- BC-788 (Bonus on C Model)
- I-152 (Bonus on C Model)
- RADAR EQUIPMENT (Specify full name plate info)
- DIRECTION FINDING EQUIP. (Specify full name plate info)
- TEST EQUIPMENT (Specify full name plate info)

Plus anything you have not listed here. Send complete description of your equipment to:

V & H RADIO & ELECTRONICS
2033 W. Venice Blvd., Los Angeles 6, Calif.
Phone: REpublic 3-1127

THEREMIN Coils & Kits

Pretested coil assemblies: Pitch Control Coil \$2.95, Volume Control Coil \$2.95, Fixed Oscillator Coil \$2.50, R.F. Transformer (T1) \$1.50, or all 4 for **ONLY \$8.95.** (Plus 1 lb. postage. We refund overpayments.)

Kit containing all parts for construction of the Therman described in this magazine. Chassis comes completely punched. Complete step-by-step wiring instructions and large, easy-to-read diagrams are included. Shipping wt. 15 lbs. **OUR PRICE \$59.95 plus postage.**

Completely assembled and tested Therman housed in a beautiful hand polished mahogany cabinet. 16 lbs. **OUR PRICE \$87.95. ONE YEAR UNCONDITIONAL GUARANTEE.**

R. A. MOOG CO. 51-09 Parsons Blvd., FLUSHING, NEW YORK

URGENT! URGENT! ELECTRONIC TUBES

We Pay Spot Cash for:

Radio, TV—all types—small and large quantities. State types, condition of merchandise, quantities and prices.

TELEVISION MATERIALS CORP.
120 Liberty St., New York 6, N.Y.
CO 7-4307

1954 Motorola TV Sets
(Continued from page 49)

lector switch is connected in the grid input of V_{15} , the 6CS6 sync separator and noise gate. In the local position, the switch has no effect on sync separator action. In the suburban position, R_{7c} is switched into the circuit in series with the control grid of V_{15} . The grid leak current, which supplies the self-bias for the sync separator action, must now flow through R_{7c} . This causes a small voltage drop across R_{7c} , resulting in the top or most positive part of the sync signal being limited. Since in weak-signal areas this top position is primarily thermal noise, it is desirable that this limiting should take place.

In the fringe position, an additional resistor, R_{25} , is switched in series with R_{7c} to still further limit thermal noise and short impulse noises.

U.H.F. Tuner TT-37

Tuner TT-37 is a continuously-tuned single superheterodyne, u.h.f. type tuner designed to convert the u.h.f. television channels in the 470 to 890-mc. range to an intermediate frequency band of 40 to 46 mc. This tuner is designed for installation in *Motorola* v.h.f. TV receivers using the TS-402, TS-502, and TS-602 series chassis. This unit may be installed in the field (through use of a suitable kit), or may be factory installed ("Y" series TV chassis).

This tuner is driven by means of a bead chain operated by a sprocket on the rear of the v.h.f. tuner fine-tuning shaft (see Fig. 4). A sprocket on the front end of the u.h.f. tuner, in turn, operates the u.h.f. dial through another bead chain. The u.h.f. dial scale is located behind the v.h.f. channel selector knob, and is visible through a window only when the v.h.f. channel selector dial is set to the u.h.f. position. In this position, the v.h.f. tuner is converted to a 2-stage 40 mc. i.f. amplifier, which amplifies the output of the TT-37 u.h.f. tuner.

The antenna (300 ohm) is coupled to the input tuning element of the double-tuned transformer by means of a rectangular coil (L_1 , Fig. 6), center-tapped and balanced to ground. The tuning elements consist of two shorted quarter-wavelength transmission lines modified by end capacity loading such that the frequency *versus* length of the inner conductor provides a straight-line relationship. The end capacity loading is so constructed that a total of three adjustments are available for antenna tracking. The two tuning elements are coupled together by means of a small printed circuit coupling loop (L_2). This coupling loop is made up of two elements or sections. The large section provides the forward coupling, and the small section is so connected to the large that it provides a bucking action that is somewhat frequency selective because of physical location. The coupling loop

NOW EICO® brings you
A LABORATORY SCOPE AT
A PRICE YOU CAN AFFORD!

Now you can enjoy all the tremendous advantages of troubleshooting with the greater speed, precision and visual meaning which only an oscilloscope gives you. With the EICO 5" Scope you can:

- Visually align TV, FM and AM sets
 - Visually signal trace and trouble-shoot every stage of any electronic device
 - Visually analyze complex waveforms
- All without disturbing circuits

425K 5" Push-Pull Scope KIT \$44.95. Wired \$79.95.



NEW 3 PROBES make 3 INSTRUMENTS of your EICO Scope

DEMODULATOR PROBE KIT \$3.75. Wired \$5.75 — For signal tracing every stage of TV, FM and AM sets.
 LOW CAPACITY PROBE KIT \$3.75. Wired \$5.75 — For broad bandwidth and high impedance circuits.
 DIRECT PROBE KIT \$2.75. Wired \$3.95 — For voltage and current measurements and general analysis.

Special introductory price, set of three PROBE KITS \$9.95. Wired \$14.95

Compare these specifications with scopes selling at many times the EICO economy price!

- Push-pull Vert. & Hor. amplifiers
- Full-screen V & H centering controls
- Intensity (Z-axis) mod.
- 6.3 volt AC, 60 cps test signal output
- Direct connections to deflection plates
- V & H Freq. Resp: 5 cps — 500 kc; usable to 2.5 mc.
- V Sens: .05 to .1 volts rms/inch
- V & H input imp: 1 megohm
- Multivibrator Sweep Generator Range: 15 cps — 75 kc
- Tubes: 2-5Y3, 2-6J5, 3-6SN7, 1-5" CRT.



See this amazing Scope value at your jobber today. Write NOW for FREE Catalog SR-1 describing the complete EICO line. Turn to our full-page ad on page 33 of this magazine.

ELECTRONIC INSTRUMENT CO., INC.
84 Withers Street, Brooklyn 11, N. Y.

A CREDIT TO YOUR HIGH FIDELITY SYSTEM

Collaro

for 7, 10, and 12 INCH RECORDS Fully Automatic

3-SPEED RECORD CHANGERS



Model 3/532
Intermixes 10 and 12 inch records.
List Price \$65.00

Model 3/531
Non-intermix.
List Price \$54.50

Model 3/534
Single record player.
List Price \$33.60

WOOD BASE
Mahogany Finish.
Specify Changer or Player.
List Price \$9.50

Available at Radio Parts Jobbers, Distributors, and Hi-Fi Dealers

Write for complete details to:

ROCKBAR CORPORATION • 215 East 37th Street, New York 16, N. Y.

FOR BEST TV RECEPTION IN ANY AREA...



use these practical aids

Mandl's Television Servicing

This famous service guide shows you, in the clearest, most practical way, how to locate and correct flaws in TV receivers and how to improve reception in fringe areas or difficult locations. You'll see how each unit in the receiver works, how it is set up by the different manufacturers, what flaws may occur in it, how these show up on the TV screen, and how to correct them. A master trouble index makes it easy to spot the cause of trouble and turn directly to the instructions for correcting it. The latest improvements, the hard-to-find troubles, and every other detail that can help you get the most out of a TV set at any location are included.



Fischer's Radio & TV Mathematics

This book makes it EASY to use the formulas and work the calculations essential for the best results in radio and TV servicing or construction. Conveniently arranged under topics such as focus and centering, antenna power, and 400 others, are the formulas to use, the numerical values to substitute and step-by-step solutions to all common problems involving math. A quick, accurate calculation is the shortest and best route to the results you want in TV. This book shows you how to make such calculations.



Noll's TV for Radiomen

One of the most widely used of all books on TV theory and construction, this book tells you in simple, non-mathematical terms the function of every TV element, and gives practical instruction on installation, alignment, and adjustment. Here is THE BASIC knowledge you need for any work on TV.

SEE THEM ON APPROVAL

The Macmillan Company, 60 Fifth Ave., N. Y. 11

Please send me the books checked below. I will either remit the full price plus small delivery charge, or return the books in ten days. (SAVE: Send check or money order and we pay delivery charge.)

- T Mandl's TV Servicing, \$5.50
 Radio & TV Mathematics \$6.75
 TV for Radiomen \$8.00

Signed _____

Address _____

This offer good only within continental limits of U.S.A.

maintains the coupling between the two tuning elements at approximately critical coupling throughout the tuning range.

The mixer crystal (CR_1) in this unit is of the plug-in type. The crystal is coupled to the double-tuned transformer by means of a tap on the center conductor of the output tuning element. The other end of the crystal returns to ground through a 56-ohm resistor (R_3) and a 10 μ fd. feedthrough-type condenser (C_3), connected in series. A 93-ohm i.f. output cable is connected across the 10- μ fd. feedthrough condenser C_3 through a 470- μ fd. coupling condenser (C_1).

A positive bias is obtained by means of a voltage divider, consisting of a 56,000-ohm resistor (R_3) and a 220-ohm resistor (R_4) to ground, and is d.c. coupled to the crystal through a 1-microhenry r.f. choke (L_1) connected from the 220-ohm resistor to the 10- μ fd. feedthrough condenser. This provides the crystal with a d.c. return path and a positive bias of approximately 0.25 volt.

The local oscillator for this tuner is a modified Colpitts type using a 6AF4 tube (V_1). Straight-line frequency-versus-travel tuning of the oscillator is obtained by a series LC type of printed circuit (L_1) on a glass cylinder. All moving elements of the circuit are capacity-coupled to stationary elements to avoid wiping contacts. The variable condenser portion of the tuning element is connected in the grid circuit and incorporates a small disc type 27 μ fd. NTC series condenser (C_6) for drift compensation. The variable inductance portion of the tuning element is connected in the plate circuit of the tube, and is so arranged as to provide its own d.c. path from plate to "B+" for "B+" feed. The moving element of the oscillator circuit consists of a core whose function is to provide a variable condenser and a variable tap on the inductance portion of the circuit and, at the same time, provide an electrical connection between the variable condenser and the variable inductance. There is only one adjustment of this core.

In order to maintain a feedback path as nearly as possible determined by the internal capacities of the oscillator tube itself, the cathode and heater of the tube are maintained off ground to r.f. potential by means of small r.f. chokes (L_2 , L_6 , and L_7), whose resonances are held at a frequency somewhat below the u.h.f. band.

The oscillator is coupled to the crystal mixer circuit by means of a small piece of braided shielded wire serving as a high-loss type of transmission line. The length of line is approximately a quarter-wavelength at the high end of the band. One end of the line is capacity-coupled to the low impedance end of the oscillator-tuned circuit by means of a small unshielded but insulated section of the inner conductor. Moving this wire, with respect to the oscillator coil, provides

RCA MI-2475 SOUND POWERED PHONES

NEW EXPORT PACKED
Shipping weight 5 lbs.

complete with 22' rubber covered cable and talk switch are light in weight, the mic is on a swivel boom that can be moved to any position in front of face. Cost \$62 ea.

Price \$13⁹⁵ Ea.



AC-METER 0-150VAC Weston or \$3.25

MOTOR 4 pole shaded pole induction 1700 RPM
G.I. 1/70 HP running torque 12 inches 1181
\$12.00 F/Tape wire or disc recording... \$3.50
HEADSET TELEX monoset Mod. 2570 reg. 14.00 4.95
MICROPHONE SHURE 707A & 534B desk stand. 4.95
RECTIFIERS Fed. Sel. 403D2787 150 MIL 130V .75
CIRCUIT BREAKERS Helmeccann Cat. 0711 5
amp 115VAC curve D. 1.00
833A tubes RCA fully guaranteed. each 16.00
SCOPE TUBES 5CP1 \$4.95, 5BP4 \$4.00, 5FP7
\$1.00, 3AP1 \$3.95, RCA 602P1 3.95
TV PICTURE TUBES 14CP4 \$16.00, 16RP4
16KP4 16TP4 Raytheon Syl. & Sheldon brand
new. Guaranteed. 18.95
WIRE HOOKUP #18 solid grey W.E. 1200 ft. roll 3.50
TA-12B trans. osc. section 4 channel new spec. 4.95
L&S Navy Waterproof speakers brand new each. 9.95
RM-29A REMOTE TEL. new W/canvas case &
ringer. 6.95
TEST SET #236 for AC DC and Ohm with prods. 3.95
MN-26C OF RECEIVER 150 to 1500 KC with 12
tubes dyn. and tuning motor in like new condi-
tion spec. 23.50
CURRENT RELAY West. 250 Ohm DC type M
with glass cover Reg. \$28.00 brand new spec. 4.95
SPRAGUE 2X2 MPD 600 VDC oil filled round ea. .75
SPRAGUE D-430 2MPD 750 VDC oil filled ea. .85
CD PC1599 1MPD 600 VAC 1250 VDC oil filled 1.25
CD T16010 1 MPD 600 VDC oil filled.75
CD TYPE 86 MICA .01 3500 VDC. 1.75
AEROVOX & CD Dykanol A 1 MFD 5000 VDC
special. KC standards CR-2B/U special. 2.95
XTALS 100 KC standards CR-2B/U special. 1.00
Include postage with order. Min. order \$3.00

McCONNELL'S New Address: BARTO, PA. Phone: BALLY 5-3621

ONLY \$495 THE NEW TV DYNATRACER

ONLY \$495
T. Ppd.
or C.O.D.
+ Chgs.

- TRACES TV SIGNALS AND VOLTAGES
- LOCATES DEFECTIVE COMPONENTS
- REQUIRES NO ADDITIONAL EQUIPMENT



This sensational new piece of test equipment is ideal for trouble-shooting television sets in the home or in the shop. The "DYNATRACER" will out-perform more expensive testers and should pay for itself on the very first repair.

A Must for Every TV Technician
SPECIFICATIONS: The "DYNATRACER" is a self-powered quality test instrument designed to trace TV signals through any Video, Sound, Sync, AFC, Horizontal or Vertical Sweep circuit—will isolate trouble to a stage or component.

ADDED FEATURE: The "DYNATRACER" will also trace voltages (50/500 V. AC/DC) and instantly locate open, shorted, intermittent or leaky (up to 20 MEGOHMS) condensers, resistors, coils, XFormers, etc.
Instruction and Trouble-Shooting Book Enclosed

10 DAY MONEY-BACK GUARANTEE
Cut out advertisement . . . attach name and address with \$5.00 bill, check or money order and mail to

Century ELECTRONICS CO.

8509-21st Ave., Dept. 209, Brooklyn 14, N. Y.

BUILD your own TV Set

YES, actually build a valuable TV Set right at home. At the same time learn all about installing, repairing, servicing—and get ready for a Big-Pay Job in America's fastest-growing, most exciting industry. The CIT TV Train-at-Home Plan is preparing hundreds for bigger pay TODAY—and a brighter Future TOMORROW. No experience needed. We supply easy-to-understand instructions—made clear with hundreds of charts, diagrams, Photos—plus TWENTY KITS of Parts, Professional Equipment and Tools. Get a TV Set to ENJOY. Get set to ENJOY a TV Future. Make money in spare time while taking Course. THOUSANDS SUCCESSING! So can You. Send today for his FREE Book, "You Can Succeed in Television."

COMMERCIAL TRADES INSTITUTE
Dept. T19-1, 1400 Greenleaf Ave., Chicago 26, Ill.

SAY YOU SAW IT IN RADIO & TELEVISION NEWS

RADIO & TELEVISION NEWS

some degree of variation in the coupling to oscillator signal. The shield of the line is grounded at several points along its length. The injection current in this tuner varies from approximately 0.7 ma. to 2 ma.

Servicing Procedure

The horizontal oscillator and its efficient operation on the correct frequency of 15,750 cps have always presented a problem to the service technician. It has caused needless time to be spent in checking the various circuit constants that determine the frequency operation of the circuit. The phase detector, which compensates for voltage changes, noise, and constant drifts that tend to throw the horizontal oscillator off frequency, has also been the center of many time-consuming operations. These include measuring the peak-to-peak voltage of the incoming sync signal and the amplitude of the saw-tooth voltage to find out if either is the cause of faulty operation. Much time is spent with a v.t.v.m. and scope trying to find out what condition *does* exist. The following simple operation on the bench can cover the circuit constants of the horizontal oscillator and the phase detector performance at the same time.

With the receiver in operation, place a jumper from the junction of the two phase detector load resistors (R_{90} and R_{91}) to the chassis. This prevents any correcting voltage from being fed to the oscillator circuit. Next, place a .1 or .25 μ f. condenser across the jack J_5 provided in the rear of the chassis. This kills the sine wave in the tank circuit. All that is left is the tube, resistor R_{106} , feedback condenser C_{95} , and the common cathode resistor R_{101} . The horizontal hold control should lock the picture in sync momentarily. Locking should occur near the center of the control range. However, noise or line change will soon cause the picture to slip. Then remove the condenser from the jack and horizontal sync should return. If not, the receiver needs phasing, which, at this stage, consists of merely adjusting the slug of L_{91} in the tank circuit.

If the hold control fails to stop the picture momentarily, one of the remaining constants are off or the 6SN7 is a poor oscillator. The tube can be checked by measuring the voltage on pin 1 with a v.t.v.m. The correct reading is 9 volts negative. If the measured voltage is more than ten per-cent below this, change tubes. R_{106} (5600 ohms) is critical in value and should be measured. Only rarely will C_{95} or R_{101} be at fault.

After finding and replacing the faulty component, the picture should again be stopped momentarily with the hold control. While the picture is stopped, remove the jumper from the junction of R_{90} and R_{91} , putting the phase detector back in operation. The picture should remain locked in; if not, change the 6SN7 phase detector tube. If the new tube does not correct the trouble,

MONEY MAKERS!

FOR MOBILE-RADIO SERVICE ENGINEERS!

Provide for future expansion in this profitable field, with Lampkin frequency- and modulation-measuring equipment.



For Any Number of Frequencies, AM or FM. The Type 105-B MFM.

The Type 105-B Micrometer Frequency Meter, or MFM, measures center-frequency on any number of nearby transmitters, AM or FM, 0.1 MC. to 175 MC. Performs as signal generator for mobile receivers, 20 MC. up. Meets FCC requirements for mobile services, with accuracy guaranteed better than 0.0025%. Can be checked against WWV. Price \$220.00 net.



The Type 205 FM Modulation Meter for Multiple Mobile Frequencies.

Instantly tunable anywhere, 25 MC. to 200 MC., the Type 205 measures maximum FM deviation due to modulation, as required by the FCC. Indicates 0-25 KC. deviation. Simple to use, easy to carry. No charts or tables. Price \$240.00 net.

Send name and address for literature

Name

Address

City..... State.....

LAMPKIN LABORATORIES, INC.
MFM DIVISION
BRADENTON, FLORIDA



Let me show you how EASY it is to

LEARN TV

the practical way--

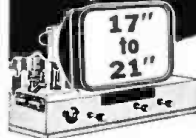

ASSEMBLE A TRANSVISION TV KIT

Pay as You Wire \$39

I WILL HELP YOU to start learning TV the practical way — by assembling a TRANSVISION TV KIT in EASY STAGES. For only \$39 you get PACKAGE #1 (standard first pkg. for all of our kits). This package gives you the BASIC CHASSIS and over 450 TV COMPONENTS with complete Instructions, Drawings, Photos, Service Booklet, and a year's subscription to my "TV and Electronics Notes". When ready, you order the next stage (pkg. #2), etc. Low prices make your complete kit a terrific buy!

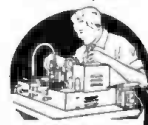

FREE CATALOG

Shows 6 Great TV Kits:

EXCLUSIVE: Only Transvision TV Kits are adaptable to UHF. Ideal for FRINGE AREAS. No Previous Technical Knowledge required. Write now!

TRANSVISION, INC., Dept. RN1
NEW ROCHELLE, N. Y.

Mr. D. Gnessin, Educational Director

TRANSVISION, INC., NEW ROCHELLE, N. Y. Dept. RN1

I'm enclosing \$_____ deposit. Send standard kit PACKAGE #1, with all Instruction Material. Balance C.O.D.

Send FREE copy of your new TV Kit Catalog.

Name _____

Address _____

City _____ State _____

POLYSTYRENE

ROD— 12" or 48" lengths.

Dia.	12"	48"	Dia.	12"	48"
1/8"	\$.03	\$.12	3/4"	\$.80	\$ 3.20
3/16"	.06	.24	1"	1.55	6.20
1/4"	.10	.40	1-1/8"	2.00	8.00
5/16"	.16	.64	1-1/4"	2.30	9.20
3/8"	.21	.84	1-3/8"	3.00	12.00
7/16"	.30	1.20	1-1/2"	3.30	13.20
1/2"	.40	1.60	1-3/4"	4.50	18.00
5/8"	.57	2.28	2"	5.90	23.60

SHEET—masking paper both sides.

Thickness	Size	Price
1/16"	12" x 12"	\$ 2.50
3/32"	12" x 12"	2.75
1/8"	12" x 12"	3.00
3/16"	12" x 12"	3.75
1/4"	12" x 12"	4.60
1/16"	12" x 24"	4.90
3/32"	12" x 24"	5.25
1/8"	12" x 24"	5.90
3/16"	12" x 24"	7.25
1/4"	12" x 24"	8.25
1/32"	20" x 20"	7.75
1/16"	24" x 24"	9.50
3/32"	24" x 24"	0.25
1/8"	24" x 24"	1.75
3/16"	24" x 24"	4.00
1/4"	24" x 24"	16.00
5/16"	20" x 20"	4.50
3/8"	20" x 20"	16.00
3/8"	24" x 24"	23.75
1/2"	20" x 20"	21.50
1/2"	24" x 24"	31.88
5/8"	20" x 20"	34.50
3/4"	20" x 20"	41.00
1"	20" x 20"	55.50

TUBING — 12" or 48" lengths.

O.D.	I.D.	12" lgth.	48" lgth.
1/4"	1/8"	\$.07	\$.28
5/16"	3/16"	.10	.40
3/8"	1/4"	.13	.52
1/2"	3/8"	.18	.72
5/8"	1/2"	.23	.92
3/4"	5/8"	.29	1.16
1"	7/8"	.38	1.52
1-1/2"	1-1/4"	1.13	4.52
2"	1-3/4"	1.50	6.00

All prices F.O.B. our warehouse New York

LEEDS RADIO CO.

75 Vesey St. Dept. A New York City 7

NEW

**Address!
Catalogue!
Merchandise!
Low, Low Prices!**

Since moving to new location COLUMBIA ELECTRONICS surges over the top with an avalanche of gear—at less-than-wholesale prices! Send for FREE CATALOGUE!

SCR-518 UHF ELECTRONIC ABSOLUTE ALTIMETER. Terrific for conversion to 420 MC and citizen's bands. Consists of transmitter, receiver, indicator, power supply, control boxes, cables with plugs, mounts, etc. Complete and BRAND NEW. **\$19.95**

Never before priced so low. ONLY..... **\$19.95**
DUMONT 3" OSCILLOGRAPH. Model 164-E. With sweep circuit. Good cond. **\$19.50**

RADAR CONTROL BOX

Consists of one 0-25 ma. 2 1/2 in. round meter. PLUS a raft of miscellaneous parts. NEW. A Moving Sales Special at only **\$5.50**

RESISTOR ASSORTMENT. 100 for only..... **98c**
GRAB BAG! Tons of good, useable gear made up of this and that. Left-overs from our moving operation. 20 POUNDS ONLY..... **\$1.50**

APS-13 "Tail End Charley" TRANSCIVER. 420 MC. UHF. 5 stages of 30 MC. IF amplifier. Complete but less tubes & dynamotor. Good cond. **\$4.95**
MINIATURE 6 V. WET CELL BATTERY. With 6 V. rev. DC motor. F.B. for R/C boat. 3 1/2 x 2 1/4 x 1 3/4". Battery less motor... **\$1.49** With motor... **\$2.99**

SLASH PRICE TUBE BUYS!

5BP4... **\$2.95** 6L6C... **.5 .49** 6AK5... **.5 .60**
5BP1... **3.49** 6AC7... **.82** 6HG... **.49**

HEAD AND CHEST SETS: Many-mile coverage. Light weight. Each... **\$3.50** PER PAIR ONLY... **\$5.95**
T-17 MIKE. Like new. Each... **\$3.50**

ARR-1 RECEIVER: For conversion to 220 MC. With schematic. See Jan/49 Radio News for conversion. Good condition. ONLY... **\$3.99**

SUPREME MODEL 600

Illuminated TUBE & SET TESTER

Tests all latest tubes. Seven in. multi-tester tests DC 0-2-500 V. in 7 ranges. AC 0-2-500 V. in 6 ranges. DC current 7 ranges: 0-1.000 microamps, 0-1,000 ma., and 0-10 amps. Ohmmeter 5 ranges: 0-20 megohms. Output meter and battery tester which tests radio batteries under load. Comes with test leads and gray metal Hammerhead 11133049 in. Factory guarantee includes 1 year of free tube testing service. BRAND NEW IN ORIGINAL BOXES. You know this set is designed to net for **\$117.50**. While they last, our **\$59.50** price—the country's lowest, only...

PR-104 VIBRATOR SUPPLY. Part of BC-654. Trans. Rec. 6 or 12 V. input. Output, positive: 0, 14 and 84 VDC; negative: 1.4, 6, 12, 51 VDC. New with spare parts... **\$9.95**

COLUMBIA'S NEW YEAR GIFT TO YOU!

SCR-183 12 V. RECEIVER & TRANSMITTER! Covers aircraft, marine and ham bands! Complete with 2 coils, control boxes, tuning head, flex cable, rack and shock mount! Plus 12 V. Dynamotor! Individual parts worth \$25.35. Approx. 25w. output. EXCEL. COND. COMPLETE! Plus schematic. Never before sold at this sensationally low price **\$15.95**

ARC-5 OR 274-N TRANSMITTERS

All pre-tested & guaranteed!
2.1-3 mcs. Brand new **\$19.95**
3-4 mcs. With tubes **29.95**
4-5 mcs. With tubes **39.95**
5-7 mcs. With tubes **49.95**
7-9.1 With tubes **14.50**
7-23 ARC-5 VHF TRANSMITTER. For C.A.P. with tubes 100-150 MC. Crystal control **29.95**

ARC-5 OR 274-N RECEIVERS

Equipped with Tuning Knobs
19-.55 kc. **\$19.95**
1.5-3 mcs. Like new **24.50**
3-6 mcs. Brand new **22.50**
3-6 mcs. With tubes **19.95**
6-9.1 mcs. With tubes. Used **7.95**
New **22.50**
6-9.1 mcs. Used. Less tubes **6.95**
BC-436 274-N Modulator. Less dynamotor. Excel. cond. **3.95**
12 V. COMMAND RECEIVER DYNAMOTOR. New **12.95**
Plus All Accessories Needed for Above. Conversion dope available on request.

Write Today—and ask for FREE CATALOGUE!
All orders F.O.B. Los Angeles. 25% deposit required. All items subject to prior sale. Note New Address. Dealer Inquiries Invited.

COLUMBIA ELECTRONIC SALES

2251-53 W. Washington Blvd., Los Angeles 18, Calif.
Come in and visit our new, larger centrally located warehouse-store!



Radio engineering is a big field. There's room for you in it—if you're good. Get first-class training at Indiana Tech. Intensive, specialized course, including strong basis in mathematics and electrical engineering, advanced radio theory and design, television, electronics, Modern laboratories. Low rate. Also B.S. DEGREE IN 27 MONTHS in Aeronautical, Chemical, Civil, Electrical and Mechanical Engineering. G.I. Government approved. Enter March, June, September, December. You can earn part of your expenses right here in Fort Wayne while you are studying.

INDIANA TECHNICAL COLLEGE

9114 E. Washington Blvd., Fort Wayne 2, Indiana
Please send me free information on B.S. Engineering Degree in 27 months as checked.

- Radio-Television Mechanical Aeronautical
 Civil Electrical Electrical

Name
Address

check the sync pulses and the returning saw-tooth for proper amplitude. One of these is causing the wrong correction voltage to appear at the junction of R_{60} and R_{67} .

Anything from incorrect clipping by the clipper to a fault in the a.g.c. circuit can be discovered by this process of checking the two incoming signals to the phase detector. The phase detector can be quickly checked by using a v.t.v.m. between the junction of R_{60} and R_{67} and chassis, and watching the voltage reading as the horizontal hold control is rotated. The voltage should vary from 2-volts negative to 2-volts positive if the sync pulses and saw-tooth are correct.

Before proceeding to the alignment of this receiver according to the instructions given in Table 1, do the following:

1. Remove the horizontal output tube, V_{11} .
2. Place a 2500-ohm, 25-watt resistor from "B++" to chassis.
3. Apply a negative 3-volt bias from an external battery to the i.f. a.g.c. line.
4. Turn the area selector switch to the local position.
5. Set the channel selector switch to channel 13.
6. Detune the oscillator by placing a 470 μ fd. condenser across the fine tuning condenser, C_{21} (Fig. 5).

TV Stations on the Air

(Continued from page 57)

CITY. STATE	CALL	CHANNEL
Cleveland	WNBK	4
Cleveland	WXEL	9
Columbus	WBNS-TV	10
Columbus	WLWC	4
Columbus	WTVN	6
Dayton	WHIO-TV	7
Dayton	WIFE	22
Dayton	WLWD	2
Lima	WLOK-TV	73
Steubenville	WSTV	9
Toledo	WSPD-TV	13
Youngstown	WFMJ-TV	73
Youngstown	WKBN-TV	27
Zanesville	WHIZ-TV	50
OKLAHOMA		
Lawton	KSWO-TV	7
Oklahoma City	KLPR-TV	19
Oklahoma City	KTVO	25
Oklahoma City	WKY-TV	4
Tulsa	KCEB	23
Tulsa	KOTV	6
OREGON		
Medford	KBES-TV	5
Portland	KOIN-TV	6
Portland	KPTV	27
PENNSYLVANIA		
Altoona	WFBG-TV	10
Bethlehem	WLEV-TV	51
Chambersburg	WCHA-TV	46
Easton	WGLV-TV	57
Erie	WICU	12
Harrisburg	WHPT-TV	55
Harrisburg	WTPA-TV	71
Johnstown	WARD-TV	56
Johnstown	WJAC-TV	6
Lancaster	WGLA-TV	8
Lebanon	WLBR-TV	15
New Castle	WKST-TV	45
Philadelphia	WCAU-TV	10
Philadelphia	WFIL-TV	6
Philadelphia	WPTZ	3
Pittsburgh	WDTV	16
Pittsburgh	WENS	2
Pittsburgh	WKPT-TV	53
Pittsburgh	WQED	13
Pittsburgh	WEEU-TV	33
Reading	WHUM-TV	61
Reading	WGBI-TV	22
Scranton	WTVU	73
Scranton	WBRE-TV	28
Wilkes-Barre	WILK-TV	34
Wilkes-Barre	WILK-TV	49
York	WNOV-TV	49
York	WSBA-TV	43
RHODE ISLAND		
Providence	WJAR-TV	10
Providence	WPRO-TV	12
SOUTH CAROLINA		
Charleston	WCSC-TV	5
Columbia	WCOS-TV	25
Columbia	WIS-TV	10
Columbia	WNOK-TV	67
Greenville	WGLV-TV	23
SOUTH DAKOTA		
Sioux Falls	KELO-TV	11
TENNESSEE		
Johnson City	WJHL-TV	11
Knoxville	WROL-TV	6
Knoxville	WTSK	26
Memphis	WHBQ-TV	13
Memphis	WMCT	5
Nashville	WSIX-TV	8
Nashville	WSM-TV	4

CITY. STATE CALL CHANNEL

CITY. STATE	CALL	CHANNEL
TEXAS		
Abilene	KRBC-TV	9
Amarillo	KFDA-TV	10
Amarillo	KGNC-TV	4
Austin	KTBC-TV	7
Dallas	KRLD-TV	4
Dallas	WFAA-TV	8
El Paso	KROD-TV	4
El Paso	KTSM-TV	5
Fort Worth	WBAP-TV	5
Galveston	KGUL-TV	11
Harlingen	KGBS-TV	4
Houston	KNUZ-TV	39
Houston	KPRC-TV	2
Houston	KUHT	8
Longview	KTVE	32
Lubbock	KCBD-TV	11
Lubbock	KDUB-TV	13
Lubbock	KTKL-TV	8
San Angelo	KEYL	5
San Antonio	WOAI-TV	4
San Antonio	KCEN-TV	6
Temple-Waco	KCMC-TV	6
Texasarkana	KETX	19
Tyler	KANG-TV	34
Waco	KFDX-TV	3
Wichita Falls	KWFT-TV	6
Wichita Falls	KWFT-TV	6
UTAH		
Salt Lake City	KDYL-TV	4
Salt Lake City	KSL-TV	5
VIRGINIA		
Hampton-Norfolk	WVEC-TV	15
Harrisonburg	WSVA-TV	3
Lynchburg	WLVA-TV	13
Newport News	WACH-TV	33
Norfolk	WTAR-TV	4
Norfolk	WTOV-TV	27
Richmond	WTVR	6
Roanoke	WLSL-TV	10
WASHINGTON		
Bellingham	KVOS-TV	12
Seattle	KING-TV	5
Spokane	KHQ-TV	6
Spokane	KXLY-TV	4
Tacoma	KMO-TV	13
Tacoma	KTNT-TV	11
Yakima	KIMA-TV	29
WEST VIRGINIA		
Charleston	WKNA-TV	49
Huntington	WSAZ-TV	3
Parkersburg	WTAP-TV	15
Wheeling	WTRF-TV	7
WISCONSIN		
Green Bay	WBAY-TV	2
Madison	WKOW-TV	27
Madison	WMTV	33
Milwaukee	WCAN-TV	25
Milwaukee	WOKY-TV	19
Milwaukee	WTMJ-TV	4
Oshkosh	WOSH-TV	48
TERRITORIES		
Anchorage	KFIA-TV	2
Honolulu	KGMB-TV	9
Honolulu	KONA	11
MEXICAN BORDER STATIONS		
Matamoros	XELD-TV	7
Tijuana	XETV	6
CANADIAN STATIONS		
Montreal, Quebec	CBFT	2
Ottawa, Ontario	CBOT	4
Toronto, Ontario	CBLT	9

NOW...enjoy luxurious hi-fi remote control!

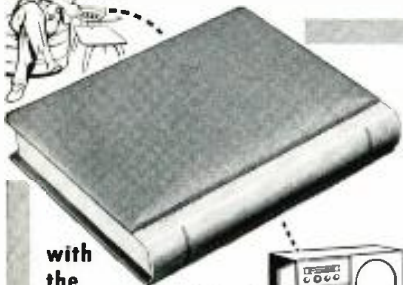

with the beautiful *Rauland*

LIBRETTO remote control

NOW you can have complete remote control of your present High Fidelity Music System with the LIBRETTO! This amazing control is completely self-powered and capable of operation several hundred feet from the amplifier. Uniquely fashioned in the form of a luxuriously bound book (only 8 3/4 x 11 x 2" thick). Backbone lifts for easy access to controls. Operates in either horizontal or vertical position. Controls: 1. Crossover; 2. Roll-off; 3. Volume; 4. Bass; 5. Treble. Adapter available for simple connection to your present system. Gives you the ultimate in luxurious Hi-Fi.

See the LIBRETTO at your Hi-Fi Dealer, or write for full details

RAULAND-BORG CORP.
3515 W. Addison, Dept. B, Chicago 18



(Advertisement)



"I've had no trouble keeping him at home now that I've had a JENSEN NEEDLE installed."

Recording System
(Continued from page 63)

the following cables to interconnect the racks: a separate multiconductor cable for low-level circuits, another for line-level circuits, and finally a third cable for the power-level circuits.

Phono pickups and similar components connect directly to a low-level terminal block below the 50W2 power amplifier. The various loudspeakers are also connected to the power-level terminal strip, as shown in the previous articles.

Line voltage is applied by means of a heavy-duty cable to the various outlet terminal strips located on the rear right channel of each rack. The line cords of the various units are greatly shortened and connect to the relay contacts through *Varicon* connectors. Individual male plugs are then inserted into the line source channels. This technique avoids unnecessary 117-volt a.c. leads from draping in back of the low-level circuits which could very easily induce hum. When it is necessary to service a component, it is easily removed from the rack, and everything may be disconnected by simply removing the connecting plugs.

Not shown is the heavy ground bus which is securely bolted to each relay rack and connected to the cold-water system for proper grounding.

Conclusion

The system described meets the requirements for a composite audio-transmission laboratory or recording studio. It provides full facilities for studies and applications of high-fidelity components. Because of its form of construction, it may be modified at will by the constructor. Substitutions in the components may be readily made without disturbing the over-all advantages of the system. —30—

PHOTO CREDITS

Page	Credit
41.....	Pickering and Company, Inc.
45, 46, 47, 48, 49.....Motorola Incorporated
54, 55.....	Admiral Corporation
58, 110.....	Karlson Associates
61.....	Consolidated Vultee Aircraft Corp.
65.....	Raytheon Mfg. Co.
96.....	Simpson Electric Co.
100.....	Audio Fair-Los Angeles
145.....	The National Foundation for Infantile Paralysis

ERRATUM

In the article "Exponential Horn Design" (November 1953 issue, page 71) a misplaced decimal point caused erroneous conclusions to be drawn. In the second column on page 72, the line "At cross-line 8 the mouth perimeter reached 448 inches" should read "44.8 inches". This gives a cut-off of 300 cycles instead of 30 cycles. The horn perimeter must be at least 440 inches for a 30 cycle cut-off. If this causes the horn dimensions to become too large, the cut-off frequency must be increased and the layout procedure repeated until the desired proportions are reached.

NEW!
4 P.E.C.* KITS

Right now there are 100,000,000 radio and TV sets — 4 or more years old — in everyday use. These sets do not have P.E.C.'s. You'll save service time and parts investment — have greater confidence in your service jobs if you replace old-style components with P.E.C.'s. Centralab P.E.C. kits are your best supply source!



PCK-18

18 P.E.C. units. Replace 42 old-style resistors and 52 old-style capacitors.
Net - - - \$9.00



PCK-110

110 P.E.C. units. Replace 255 old-style resistors and 52 old-style capacitors.
Net - - - \$55.80



PCK-220

220 P.E.C. units. Replace 525 old-style resistors and 133 old-style capacitors.
Net - - - \$115.80



PCK-45

45 P.E.C. units. Replace 106 old-style resistors and 133 old-style capacitors.
Net - - - \$24.00



This P.E.C. Guide No. 2 (included with each kit) tells you how and when to use P.E.C.'s. Shows cross indexing — schematics — tells you how to test P.E.C.'s. Get complete details from your CRI distributor or use coupon below.

Centralab

*Trademark — Printed Electronic Circuits

CENTRALAB
A Division of Globe-Union Inc.
910-AE. Keefe Ave., Milwaukee 1, Wis.
Please send name of distributor stocking P.E.C. Kits, also additional technical data.

Name.....
Firm.....
Address.....
City..... Zone..... State.....

REAL SALE TUBE WHOLESALE PRICES!

STANDARD BRANDS

- FULLY GUARANTEED
- INDIVIDUALLY BOXED
- FIRST QUALITY

Tube Orders Over \$15.00. with full remittance, PREPAID to you in U.S.A.

Type	Net	Type	Net	Type	Net
0A2	.90	6B8	.75	12BA6	.65
0A3/VR15	1.05	6BA6	.60	12BD6	.64
0B2	.80	6BC5	.69	12BE6	.75
0C3/VR105	.95	6BE6	.63	12BH7	.85
0D3/VR150	.95	6BG6	1.80	12BY7	1.03
0Z4	.59	6BH6	.80	12C7	1.11
1A7GT	.77	6BJ6	.85	12SA7	.64
1AX2	1.15	6BK7	1.10	12SF5	.70
1B3GT	.85	6BL7GT	1.00	12SG7	.80
1B27	11.50	6BN6	1.20	12SH7	.63
1W5GT	.77	6BQ6GT	1.25	12SJ5	.65
1L4	.60	6BQ7A	1.23	12SK7	.65
1L6	.95	6BZ7	1.28	12SL7GT	.75
1L8A	1.10	6C4	.50	12SN7GT	.75
1L8A	1.10	6C6	.50	12SQ7GT	.55
1L9	1.10	6C8B	.65	12SR7	.69
1N5GT	.95			12SX7GT	1.10
1N23A	2.05	6CD6G	1.80	14F7	.75
1N23B	2.25	6CU6	2.10	19BGGG	2.05
1N34A	.75	6D6	.75	25AV5	1.20
1N4E	.50	6F4	3.50	25BQ6GT	1.25
1N4	.79	6F5	.68	25L6GT	.62
1M4, 1299	.59	6F5GT	.68	25W4GT	.65
1R5	.75	6F6	.70	25Z5	.75
1S5	.70	6F6G	.80	25Z6GT	.59
1T4	.75	6F8G	.85	28D7	1.35
1U4	.50	6GG6	.85	35A5	.62
1U5	.70	6H6	.59	35B5	.60
1V	1.03	6J4 (RCA)	5.10	35C5	.80
1V2	.70	6J5	.50	35L6GT	.62
1Z7A	.85	6J6	.75	39W4	.45
1Z7	3.25	6J7	.75	35Z3	.70
2C39A	12.75	6KA (Sylv)	2.25	35Z5GT	.44
2C40	6.75	6KA	2.25	45A5	.75
2C51	3.90	6K6GT	.59	50B5	.60
2E30 (Hyt)	2.05	6K7	.60	50C5	.65
2J39	7.95	6L6G	1.10	50L6GT	.65
2J61	37.50	6L6GA	1.10	80	.66
2J62	33.09	6L6M	1.25	91	.75
2K28	27.55	6L7	.80	94/67A	1.10
2X2	.35	6N7M	.80	117/23	.85
3A4	.54	6P7G	.88	117/23	.75
3BP11	9.00	6Q7GT	.80	117/26	.88
3B7/2291	.39	6S4	.58	211/VTAC	.88
3B26	4.25	6S7M	.98	250TH	1.35
3C23 (GE)	8.50	6S47	.64	274B	3.00
3C24, 24G	1.15	6SC7	.88	304TH	7.75
3D6, 1299	.35	6SD7GT	.80	304TL	8.75
3Q4	.89	6SG7	.66	310A (WE)	3.50
3Q5GT	.90	6SH7	.98	407A (WE)	3.50
3S4	.75	6SJ7	.65	408A (WE)	2.50
3L4	.70	6SK7	.77	A	.88
3V4	.75	6SL7GT	.55	725A	4.10
3X2500-A3	135.00	6SN7GT	.72	803	3.25
4B24	4.50	6SQ7	.58	805	3.25
4D22	18.50	6T8	.85	807	3.25
4X150A	29.95	6U8	.90	811A	3.50
5D21 (WE)	12.50	6V3	1.15	812A	3.60
5R4G	1.50	6V6GT	.61	816	1.20
5U4G	.56	6V8	.99	898B	8.99
5V4G	.92	6W4GT	.59	898B	2.75
5W4G	.80	6W6GT	.75	82A	9.99
5X4G	.75	6X5GT	.50	866A (JAN)	1.75
5Y3GT	.44	6X8	.85	866A (CBS)	1.75
6A8GT	1.10	7A7	.75	869B	65.00
6AB4	.65	7A8	.69	872A	3.25
6AB7	.95	7B7	.76	855	4.25
6AC7	1.04	7B8	.78	891/NE16	.50
6AC7 JAN	.80	7C4	.29	CK1005	.75
6AF4	1.39	7C5	.69	1616	.88
6AG5	.65	7C6	.69	1622/6L6M	1.35
6AG7	1.10	7C30	.85	1625	.35
6AH4GT	.80	7E5	.39	1626	.18
6AH6	.88	7F7	.85	1629	.25
6AJ5	1.30	7F8G	1.55	2050	1.55
6AK5	.79	7BP7	4.25	9516 (Hyt)	7.25
6AK6	.58	7H7	.70	5528/C6L	5.00
6ALS	.55	7H7	1.20	5551/FG271	57.50
6AN4	1.30	7Q7	.98	5554	1.75
6AQ5	.35	12A4	.98	5656	10.00
6AQ6	.73	12A7	.50	5670	3.50
6AS5	.70	12A77	.89	5687	2.95
6AS6	1.95	12AV6	.50	5691	7.60
6AT5	.48	12A07	.70	5693	6.25
6A06	.59	12AV7	.90	5814	2.20
6AV5GT	1.10	12AW6	.88	9002	1.75
6AV6	.48	12AX7	.70	9003	1.10
6AX4GT	.72	12AY7	1.90	9004	3.35
6AX5GT	.80	12B4	.98	9006	.21

Above is only a partial listing of our huge stock. Types not listed may be ordered at approx. the same savings. Many new special purpose types in stock.

AUTHORIZED DISTRIBUTORS

CBS-HYTRON WESTINGHOUSE

TUBE CARTONS

Two Colored Cartons With New Safety Partitions. Prevents Tube Breakage.

SIZE	EACH
Miniature (6AUG, 6ALS, etc.)	5.01
GT (6SN7, 6W4, etc.)	.0125
LARGE GT (1B3, 6BQ6GT, etc.)	.015
LARGE C (5U4G, 6BQ6G, etc.)	.02

Minimum—100 any one size.
Quantity prices on request.
FREE SAMPLE. If requested on your letterhead.



136 F Liberty Street, N.Y. 6, N.Y. REctor 2-2562

Terms: 25% with order, balance C.O.D. All merchandise guaranteed. F.O.B. N.Y.C.

INDEX OF Advertisers

JANUARY 1954

While every precaution is taken to insure accuracy, we cannot guarantee against the possibility of an occasional change or omission in the preparation of this index.

ADVERTISER	PAGE	ADVERTISER	PAGE
Airex Radio Corp.	96	MacMillan Company	160
All Channel Antenna Corp.	27	McConnell's	135, 160
Alliance Manufacturing Company	97	McGraw-Hill Book Company, Inc.	126
Allied Radio Corp.	9	Mallory & Co., Inc., P. R.	77, Fourth Cover
American Microphone Co.	106	Mattison Radio & Television Corporation	125
American Phenolic Corporation	82, 83	Midwest Radio Corp.	117
American Television & Radio Co.	121	Miles Reproducer Co.	137
Amplifier Corp. of America	138	Milwaukee School of Engineering	140
Argyle Electronics, Inc.	128	Moog Co., R. A.	141, 158
Arkay Radio Kits	104	Moss Electronic Distributing Co., Inc.	105
Arrow Sales Inc.	127	National Electronics of Cleveland	165
Associated Industries	152	National Radio Institute	19, 20
Asche Radio Company, Walter	109	National Schools	15
Atlas Sound Corp.	146	Newark Electric Company	145
Audel, Publishers	138	Newark Surplus Materials	138
Baltimore Technical Institute	108	New Jersey Television Supply Co.	151
Barry Electronics Corp.	164	Onan & Sons, Inc., D. W.	142
Bell Telephone	12	Orradio Corporation	104
Berlant Associates	128	Partmart	130
Boulevard Electronics, Inc.	149	Peak Electronics Co.	148
Burstein-Applebee Co.	34	Permoflux Co.	149
CBS Hytron	21	Phillips Tube Co.	118
Candler System Co.	141	Photo Sales	142
Capitol Radio Engineering Institute	29	Pickering & Company, Incorporated	3
Centralab	26, 80, 103, 145, 153, 163	Platt Electronics Corp.	98
Century Electronics Co.	160	Precision Radio Electronics	135
Channel Master Corp.	32, 33	Premax Products	106
Cisin, H. G., Publisher	116	Premier Radio Tube Co.	110
Cleveland Institute of Radio Electronics	101, 102	Progressive Edu-Kits Inc.	143
Collins Audio Products Co., Inc.	111	Quietrole Company	144
Columbia Electronic Sales	162	RCA Institutes, Inc.	81, 137
Commercial Trade Institute	160	R. W. Electronics	113
Commissioned Electronics Co.	108	Radiart Corporation	6
Communication Equipment Co.	153	Radio Corporation of America	31
Concord Radio	147	Radio Craftsmen, Inc.	16
Corona Radio & TV Co.	141	Radio Shack Corporation	133
Coyne School	35	Radio-Television Training Association	23
DeForest's Training, Inc.	5	Rad-Tel Tube Co.	123
Editors & Engineers Ltd.	150	Rauland-Borg	163
Electronic Instrument Corp.	165	Raytheon Mfg. Company	Second Cover
Electronic Instrument Co., Inc.	36, 159	Relyance Merchandising Corporation	114
Electronic Specialty Supply Co.	137	Rider Publisher, Inc., John F.	115, 155
Electro Products Laboratories	154	Rinehart Books, Inc.	98, 107, 124, 142, 157
Electro Voice	8	Rock Bar Corporation	159
Fair Radio Sales	141	Sams & Co., Inc., Howard W.	120, 130
Federal Telephone & Radio Company	10, 11	Sangamo Electric Company	28
Fisher Radio Corporation	18, 99, 119	Scott, Inc., H. H.	112
G & G Radio Supply Co.	157	Shure Brothers Inc.	146
G & H Wood Products Co.	147	Simpson Electric Co.	131
G. L. Electronics	100, 139	South River Metal Products Co., Inc.	154
Gonset Co.	155	Sprayberry Academy of Radio	17
Greenlee Tool Co.	125	Stan-Burn Radio & Electronics Co.	134
Gyro Electronics Co.	137	Stephan Sales Corp.	158
Hallcrafters	7	Steve-El Electronics Corp.	151
Harjo Sales Co.	104	Stevens Walden, Inc.	136
Harvey Radio Company	132	Stuart Electronic Distributors Co.	131
Heath Company	84, 95	Sun Parts Distributors, Ltd.	136
Henshaw Radio Supply	135	Suprex Electronics Corp.	150
Hughes Research & Development Laboratories	149	Supreme Publications	129
Indiana Technical College	162	Sylvania Electric Products, Inc.	14, 22, 121
International Correspondence Schools	13	Tab	166
International Rectifier Corporation	126	Tallen Co., Inc.	155
International Resistance Co.	Third Cover	Tele-Beam Industries	118
Jensen Industries, Inc.	163	Television Communications Institute	112
JFD Mfg. Company, Inc.	134	Television Materials Corp.	158
J. J. Glass Electronics Co.	140	Terado Company	158
J S H Sales Co.	146	Transamerica Electronics Corp.	138
Karlson Associates, Incorporated	156	Transvision, Inc.	150, 161
Kay-Townes Antenna Company	78, 79	Trio Manufacturing Co.	24, 25
Lampkin Laboratories Inc.	161	Tri-State College	118
Leeds Radio Co.	161	Utah Radio Products Co., Inc.	139
Leotone Radio Co.	106	V & H Electronic Industries, Inc.	158
Loris Sales	139	Valparaiso Technical Institute	104
		Waldom Electronics, Inc.	154
		Waisco Electronics Corporation	30
		Western Electronics Co.	108
		Western Television Institute	165
		Westinghouse Electric Corporation	74, 75
		Wholesale Radio Parts Co., Inc.	129
		Windsor Electronic Tube Co.	108
		World Radio Laboratories	135

Classified

Rate 50c per word. Minimum 10 words

RADIO ENGINEERING

COMPLETE radio, electronics theory & practice; television; broadcasting; servicing; aviation, marine, police radio, 12 or 18 months. Catalog. Valparaiso Technical Institute, Dept. N, Valparaiso, Ind.

FOR SALE

ISOLATION transformer 35w 117v sec. 117 or 135 plus 6.3v .45a tap. 3 lbs. \$2.45 plus postage. Send for flyer. Surplus bought. Empire Electronics Co., 409a Ave. L, Brooklyn 30, N. Y.

DIAGRAMS—Radio \$1.00; record changers, recorders \$1.25. Television with service data \$2.00. Where model unknown, give part numbers. Kramer's Radio Service, Dept. S53, 36 Columbus Ave., New York 23, N. Y.

TUBES and equipment bought, sold, and exchanged. For action and a fair deal, write B. N. Gensler, W2LNI, 136-F Liberty, New York 6, N. Y.

TAPE Recorders, Tapes, Accessories. Unusual Values. Dressner, 624-R East 20th St., N.Y.C. 9.

FREE, Bargain List, tubes bought, sold. Write Mark, Box 14, New York City 72.

ALUMINUM tubing, angle and channel, plain and perforated sheet. Willard Radcliff, Fostoria, Ohio.

AUTO radios, all models, best brands. Wholesale. Free catalog. Radio Frank, 14456 Michigan, Dearborn, Mich.

CRYSTALS: Tailor made FT-243's 3500 to 8700 KC \pm 2Kc \$1.00 each, .01% \$2.00 each. Hundley Crystal Co., 2951 North 36th, Kansas City 4, Kan.

CABINET drawer slides, heavy gauge steel, 18 inch track, 14 inch channel \$98 pair. Domco, 3023 Radcliffe Ave., New York, N. Y.

USED televisions \$30 up. WAPI, 1120 South Randolph, Arlington, Virginia.

FREE: Get our monthly electronic lists. Dick Rose, Everett, Wash.

TV-FM antennas. All types including UHF. Mounts, accessories. Lowest prices. Wholesale Supply Co., Dept. H, Lunenburg, Mass.

WANTED

AN/APR-1, other "APR-," "ARR-," "TS-," "IE-," ARC-1, ARC-3, ART-13, everything surplus; Tubes, Manuals, Laboratory equipment. Describe, price in first letter. For Sale: Reconditioned Watthour Meters, four for \$10.00. Engineering Associates, 434 Patterson Rd., Dayton 9, Ohio.

WILL buy all ART-13/type T-47A \$200.00; ART-13/type T-47, \$150.00; BC-348 unmodified \$65.00, BC-348 modified \$50.00; APN-9 \$200.00; ARC-3 complete \$600.00; R77 Receivers \$300.00; ARC-1 \$300.00; BC-312 \$60.00; BC-312 \$60.00. Ship via Express C.O.D., subject to inspection to: H. Finnegan, 49 Washington Avenue, Little Ferry, N. J.

CORRESPONDENCE COURSES

AMATEUR radio is fun. Fifty pages, easy to understand, code and theory for Novice Class license. \$1.00. Satisfaction guaranteed. Radiographic, 3246 North Orange, Chicago, Ill.

F.C.C. commercial operator license quickly. Individualized training. Correspondence or residence. Results guaranteed. Dept. 102, Grantham School, 6064 Hollywood Blvd., Hollywood, California.

BUSINESS OPPORTUNITIES

BUY Wholesale 25,000 items, Catalog 25c. Matthews, 1172-R4 Broadway, N. Y. C. 36.

AVAILABLE: Distributorship for famous line of German Radios and Combinations for: Eastern States and Pacific area. Product attracts on sight and completely sells on tone. Excellent opportunity for the distributor who wants to supply his dealers with an out-of-the-ordinary product for their tone-minded customers. Address: Box #538, % Radio & TV News, 366 Madison Ave., New York, New York.

MISCELLANEOUS

SPEAKERS repaired, wholesale prices, guaranteed workmanship. Amprite Speaker Service, 70 Vesey St., New York City 7.

21 PAGES Plans, one tube receiver (record 12,000 miles) with 6 issues Radiobuilder \$1.00. Laboratories, 328-H Fuller, Redwood City, Calif.

TV-RADIO Dealers—We offer an exclusive, hard hitting and effective advertising program. This program designed to make you best known in your trading area. For details write Servicemarks, Box 512, Kinston, N. C.

January, 1954

National Electronics GREATEST Special Purchase BARGAIN Tremendous Savings While They Last

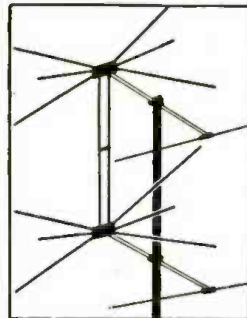

2 BAY 16 ELEMENT CONICAL ARRAY WITH STURDY 3/8" ELEMENTS AND HIGH BAND ADAPTERS \$4.99 Each IN LOTS OF THREE Single Lots \$530

Never before has National Electronics had a BARGAIN like this. We made a special purchase in order to get these sensational prices. And this array has everything. This conical 2-bay 16-element array provides ultra-fine fringe reception. Includes sixteen "airplane type" aluminum elements, including hi-band adapters for greater gain on the high channels and is complete with one pair of stacking bars to each array. These are packed in cartons of three 16-element arrays per carton, with tie rods, at \$14.95 per carton. When purchased in single 16-element arrays, separately boxed—your cost is: 3 5.30 each 3 Two-Bay Arrays per carton without Tie Rods 13.50 carton 4 Bay Ultra-Fringe Stacking Assembly for Arrays—Model 4-B 1.95 set

FAMOUS ROCKET ZOOM-UP TOWERS

Sturdy • Reliable • Easiest Installation Economize with Rocket Zoom-up Towers. Offers simplest, easiest way to make an installation up to 50'. Each section telescopes inside the other—to erect, simply slide out each section in its turn—insert bolt, turn section below—tighten to keep mast from turning. Each tower complete with guy rings, bolts, and mounting base suitable for peak or flat roof. Handsome and sturdy. Rocket Zoom-ups offer you economy and long life. Order by size.

20'	\$ 9.95	30'	\$16.95
40'	21.95	50'	32.95

(deduct 10% discount in lots of 3)

Sensational Low Prices on UHF Accessories M-5-C 5' steel mast extender (erlipped to mate with 1 1/2" steel mast) \$1.05 UHF low-loss tubular twin-lead-100' coil 4.95 71" UHF mast stand-off .13 71" UHF screw stand-off .06 UHF-UHF antenna coupler-low-loss 2.75 ea.

SUPER SENSATIONAL!

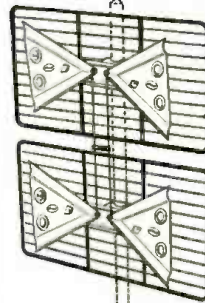

BOW TIE UHF REFLECTOR Ultra High Gain Bargain Priced at \$1.95 ONLY For Single Array ONLY \$4.40 For Two-Bay Array

We are offering the HIGHEST UHF TV Antenna Bargain ever offered. The two-bay array where greater gain is required—and the 4-bay array for fringe. At this sensational low price this antenna is the BEST BUY on the market. Get your needs filled while they last!

In lots of 6, individually cartoned \$10.95 for 6 4-bay arrays, with tie rods 8.75 ea. Matching tie rods—per pair .50 pr.



TR-2 RADIART TELEROTOR WITH DIRECTION INDICATOR

Streamlined, waterproof, sturdy. 12 heavy duty ball bearings. Heavy-duty reinforced die-cut housing. Precision gears. Positive stop at end of rotation. Heavy duty motor reverses instantly. Mast, tower or platform mounting. Factory tuned for life. Perfect pattern dial gives immediate indication of antenna position. Requires 8 Conductor cable. 8 Conductor Wire \$.08 ft.

\$29.37

UHF STRIPS—Now available for Standard Coil tuners. To order, specify channel No. and series designated by letter, such as F, G, Q, etc., stamped on each strip of your present tuner. (Set consists of osc. & ant.) \$7.50 Ea.

ALL PRICES F.O.B. CLEVELAND, OHIO Do not remit more than complete purchase price. Pay shipping charges on receipt of goods. 25% deposit on all C.O.D. orders, please. Money-back guarantee. Prices Subject to Change Without Notice

National Electronics OF CLEVELAND THE HOUSE OF TV VALUES 101 Delco Building Cleveland 3, Ohio

STOP VOLUME CONTROL NOISE!

"NO NOISE"

New 6 oz. Spray Can

Net to Servicemen \$2.25

CONTAINS AMAZING NEW **PERMA-FILM**

- ★ CLEANS! . . . dirt and oxidation immediately on contact.
- ★ LUBRICATES! . . . 1 drop eliminates scratch, hum and noise.
- ★ PROTECTS! . . . assured continued top performance.

Perfect Contact Restorer—cleans & restores volume controls, hand switches, push button assemblies, electrical contacts. NO NOISE is not a carbon tet solution.

"NO NOISE"

2 oz. bottles, Net to Servicemen \$1.00

Available in 8 oz. bottles and quart cans. Nearest distributor—or write

ELECTRONIC CHEMICAL CORP.
813 Communipaw Ave., Jersey City 4, N. J.

EARN MORE MONEY— BE A PROFESSIONAL TELEVISION SERVICE TECHNICIAN

STEP INTO THE TOP PAY \$5,000—\$10,000 A YEAR CLASS. 7 MONTHS' SHOP TRAINING QUALIFIES YOU.

If you want to reach your goal as a Successful Service Technician you will need plenty of "KNOW HOW" to qualify for the better servicing jobs or profitable shop ownership.

SEND FOR FREE BOOK TODAY!

WESTERN TV offers real experience on live equipment in our BIG SHOPS AND LABORATORIES in the shortest practical time under expert instructors. Graduates are in big demand because they have the "field experience" necessary for immediate "bench" or supervisory positions. You learn every phase of Radio and TV servicing (AM, FM, VHF, UHF). WTI men win fast promotion . . . can demand better pay . . . develop highly profitable businesses of their own with the latest and most PRACTICAL PERSONALIZED TRAINING BEHIND THEM. You concentrate all your time on being a PROFESSIONAL TV SERVICE TECHNICIAN—non-essential math and engineering theory omitted. YOU CAN EARN WHILE YOU LEARN. Special Finance Plan. APPROVED FOR VETERANS. Find out how you can get into the TOP PAY GROUP—Send for this fact-packed book NOW!

WESTERN TELEVISION INSTITUTE America's Leading Television Servicing School

Western Television Institute Dept. R-14 341 W. 18th St., Los Angeles 15, Calif. Without obligation, please send FREE fully illustrated booklet. (No salesman will call.)

NAME _____ AGE _____ ADDRESS _____ CITY _____ ZONE _____ STATE _____

NO. 1

CHOICE

of service technicians for

TV CONTROLS*



*Not Claims! Not Predictions!
But Plain Facts! More Service
Technicians prefer IRC TV Controls
than the next 2 brands combined.
Proved by unbiased, authoritative,
independent surveys.*



**ASK FOR *IRC* TV CONTROLS...
MOST SERVICE TECHNICIANS DO!**



INTERNATIONAL RESISTANCE COMPANY

415 N. Broad Street, Philadelphia 8, Pa.

In Canada: International Resistance Co., Ltd., Toronto, Licensee

Wherever the Circuit Says 

Depend on Mallory
for
Approved Precision Quality



There'll Be No Call-Back On This Job!

You can be sure there will be no time-wasting call-backs to cut down your profits when you use Mallory Capacitors. Mallory Capacitors are engineered to meet the electrical requirements of any TV or radio set. You can depend on them to give long-lasting performance that's equal to . . . and often better than . . . any original equipment component.



Rating-for-rating, Mallory FP Capacitors give longer life at higher temperatures and greater ripple currents. They'll give trouble-free performance at 185° F. (85° C.). They are the only fabricated plate capacitors on the replacement market.



For all plastic tubular replacements you can count on Mallory Plascaps® the same way you do on FP's. They eliminate problems of shorting, leakage, unsoldered leads and off-center cartridges.

Nothing will lose a customer faster than a set that won't stay repaired. That's why it is always good business to specify *brand* as well as rating when you order parts. And if you depend on Mallory you can put an end to call-backs, get precision quality, yet pay no more.

P. R. MALLORY & CO. Inc.
MALLORY

CAPACITORS • CONTROLS • VIBRATORS • SWITCHES • RESISTORS
RECTIFIERS • POWER SUPPLIES • FILTERS • MERCURY BATTERIES
APPROVED PRECISION PRODUCTS

P. R. MALLORY & CO. Inc., INDIANAPOLIS 6, INDIANA